

TOSHIBA INSTALLATION MANUAL

AIR CONDITIONER (SPLIT TYPE)

Not accessible to the general public

4-Way Air Discharge Cassette Type

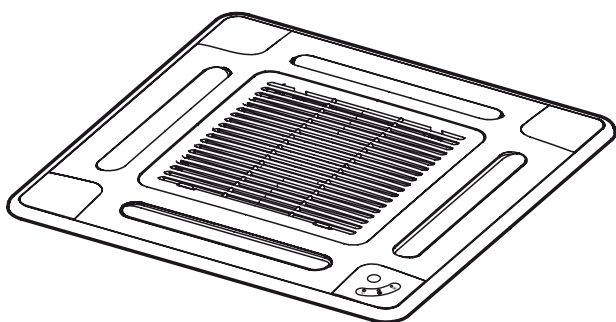

Indoor Unit	
Heat Pump Model	Cooling Only Model
RAS-M10SMUV-E RAS-M13SMUV-E RAS-M16SMUV-E	RAS-M10SMUCV-E RAS-M13SMUCV-E RAS-M16SMUCV-E
Ceiling panel	
RB-B11MC(W)E	

ENGLISH

EN

CONTENTS

ENGLISH

1	SAFETY PRECAUTIONS.....	1
2	ACCESSORY PARTS AND PARTS TO BE PROCURED LOCALLY	3
3	SELECTION OF INSTALLATION PLACE.....	4
4	INSTALLATION OF INDOOR UNIT	6
5	DRAIN PIPING WORK	11
6	REFRIGERANT PIPING AND EVACUATING.....	15
7	EVACUATING	17
8	ELECTRICAL WORK.....	18
9	APPLICABLE CONTROLS.....	21
10	TEST OPERATION	23
11	INSTALLATION/SERVICING TOOLS.....	23
12	MAINTENANCE	24

Please read this Installation Manual carefully before installing the Air Conditioner.

- This Manual describes the installation method of the indoor unit.
- For installation of the outdoor unit, follow the Installation Manual attached to the outdoor unit.

ADOPTION OF NEW REFRIGERANT

This Air Conditioner is a new type which adopts the new refrigerant HFC (R410A) instead of the conventional refrigerant R22. R410A is an ozone friendly refrigerant.

1 SAFETY PRECAUTIONS

- Ensure that all Local, National and International regulations are satisfied.
- Read this "SAFETY PRECAUTIONS" carefully before Installation.
- The precautions described below include the important items regarding safety. Observe them without fail.
- After the installation work, perform a trial operation to check for any problem. Follow the Owner's Manual to explain how to use and maintain the unit to the customer.
- Turn off the main power supply switch (or breaker) before the unit maintenance.
- Ask the customer to keep the Installation Manual together with the Owner's Manual.

CAUTION

New Refrigerant Air Conditioner Installation

• THIS AIR CONDITIONER ADOPTS THE NEW HFC REFRIGERANT (R410A) WHICH DOES NOT DESTROY OZONE LAYER.

R410A refrigerant is apt to be affected by impurities such as water, oxidizing membrane, and oils because the working pressure of R410A refrigerant is approx. 1.6 times as that of refrigerant R22. Accompanied with the adoption of the new refrigerant, the refrigeration machine oil has also been changed. Therefore, during installation work, be sure that water, dust, former refrigerant, or refrigeration machine oil does not enter the new type refrigerant R410A air conditioner circuit.

To prevent mixing of refrigerant or refrigerating machine oil, the sizes of connecting sections of charging port on main unit and installation tools are different from those of the conventional refrigerant units. Accordingly, special tools are required for the new refrigerant (R410A) units as shown on page 23. For connecting pipes, use new and clean piping materials with high pressure fittings made for R410A only, so that water and/or dust does not enter. Moreover, do not use the existing piping because there are some problems with pressure fittings and possible impurities in existing piping.

CAUTION

TO DISCONNECT THE APPLIANCE FROM THE MAIN POWER SUPPLY

Disconnection from the supply mains:

The means for disconnection must be incorporated in the fixed wiring in accordance with the wiring rules.

WARNING

- Ask an authorized dealer or qualified installation professional to install/maintain the air conditioner. Inappropriate installation may result in water leakage, electric shock or fire.
- Turn off the main power supply switch or breaker before attempting any electrical work. Make sure all power switches are off. Failure to do so may cause an electric shock.
- Connect all of the installation wiring correctly. If the installation wiring is incorrect, electrical parts may be damaged.
- When moving the air-conditioner for installation to another place, be very careful not to allow the specified refrigerant (R410A) to become mixed with any other gaseous body into the refrigeration circuit. If air or any other gas mixes with the refrigerant, the gas pressure in the refrigeration circuit will become abnormally high and it may result in the pipe bursting or personnel injuries.
- Do not modify this unit by removing any of the safety guards or by overriding any of the safety interlock switches.
- Exposure of the unit to water or other forms of moisture before installation may cause a short circuit of the electrical parts. Do not store it in a wet basement or expose to rain or water.
- The electrical work should be performed by a qualified electrician in accordance with the technical standards for electrical equipment, internal wiring regulations, and installation manual for the electrical equipment. A dedicated circuit should be used, and the voltage should match the rated voltage of the product. If the power supply circuit does not have enough capacity or the work is performed improperly, an electric shock or fire can result.
- Be sure to connect the indoor and outdoor unit wires at their tips. Do not connect the wires below the tips. If the connections and fixtures are not made properly, overheating or a fire can result.
- Connect the wiring between the indoor and outdoor units so that the cord clamp does not stick out, and attach the covers properly. If the clamp is not attached properly, the terminal sections can overheat, and a fire or electric shock can result.
- Always use the supplied parts or specified parts for the installation work parts. Usage of different parts can cause the unit to fall, a water leak, fire, or electric shock.
- After unpacking the unit, examine for possible damage.
- Do not install in a place that might increase the vibration of the unit.
- To avoid personal injury (with sharp edges), be careful when handling parts.
- Perform installation work properly according to the Installation Manual. Incorrect installation may result in water leakage, electric shock or a fire.













- When the air conditioner is installed in a small room, provide appropriate measures to ensure that in the event of a refrigerant leak the rooms does not exceed the critical level.
- Install the air conditioner securely in a location where the base can sustain the weight of the unit adequately.
- Perform the specified installation work to guard against an earthquake.
If the air conditioner is not installed appropriately, accidents may occur due to the unit falling.
- If refrigerant gas has leaked during the installation work, ventilate the room immediately.
If the leaked refrigerant gas comes in contact with fire, noxious gases may be generated.
- After the installation work, confirm that refrigerant gas does not leak.
If refrigerant gas leaks into the room and flows near a fire source, such as a cooking range, noxious gases maybe generated.
- Use only the specified wiring during the unit installation. Ensure that all terminals are securely fixed, so preventing any external forces having a negative effect on the terminals.
- Be sure to provide grounding.
Do not connect ground wires to gas pipes, water pipes, lightning rods or ground wires for telephone cables.
- Do not install the air conditioner in a location that maybe subjected to a risk of exposure to a combustible gas.
If a combustible gas leaks and becomes concentrated around the unit, a fire may occur.
- Do not install in locations where the unit will get splashed by water or with high humidity such as bathrooms. This can cause deterioration of the insulation, resulting in an electric shock or fire.
- Check the following points before starting operation in the installation work.
 - The pipes are securely connected and do not leak.
 - The service valve is opened.
 Operating the compressor while the service valve is closed will result in an abnormally high pressure, and can possibly damage the compressor and other parts. Also, any leaks in the connections can cause air to be sucked in, resulting in an even higher abnormally pressure, and can cause a pipe rupture or injury.
- When carrying out the pump-down work, shut down the compressor before disconnecting the refrigerant pipe. Disconnecting the refrigerant pipe with the service valve left open and with the compressor still operating will cause air, etc. to be sucked in, raising the pressure inside the refrigeration cycle to an abnormally high level, and possibly resulting in rupturing, injury, etc.

CAUTION

- Wear work gloves when carrying out the installation work or repairs. Contact with parts, etc. may cause injury if the work or repairs are conducted without wearing gloves.
- Earth leakage breakers are required in certain installation locations. Failure to install the earth leakage breakers can result in an electric shock.
- The pipes for the drain work should be installed properly in accordance with the installation manual to ensure proper draining. Failure to install the pipes properly can cause a leak indoors and wet the furniture and other objects in the home.
- Tighten the flare nut with a torque wrench using the specified method. If the flare nut is over-tightened, it can crack over a long period of time, resulting in a refrigerant leak.
- Do not touch the inlets or aluminum fins of the indoor and outdoor unit. An injury could result.
- Do not install the outdoor unit where small animals typically live. If small animals get inside the unit and touch the electrical parts, a failure or fire can result. Also, please keep the area around the outdoor unit clear of fallen leaves and other objects.
- After the installation work is completed, perform test operation to check that there is nothing abnormal, and explain to the customer the operating and cleaning procedures based on the owner's manual. Also, ask the customer to store this installation manual together with the owner's manual.

2 ACCESSORY PARTS AND PARTS TO BE PROCURED LOCALLY

Accessory parts

Part name	Q'ty	Shape	Usage
Installation Manual	1	This manual	(Be sure to hand over to customers)
Wireless remote controller	1		—
Remote controller holder	1		—
Mounting screws for remote controller holder 3.1 mm (diam.) × 16 mm	1		—
Batteries (Manganese)	2		—
Heat insulating pipe	2		For heat insulation of pipe connecting section
Installation pattern	1	—	For confirmation of ceiling opening and main unit position
Installation gauge	2		For positioning of ceiling position (united with installation pattern)
Pattern fixing screw	4	M5 × 16L	For attach the installation pattern
Heat insulator	1		For heat insulation of drain connecting section
Washer	8		For hanging-down unit
Hose band	1		For connecting drain pipe
Flexible hose	1		For adjusting core-out of drain pipe
Heat insulator A	1		For sealing of wire connecting port
Heat insulator B	1		For sealing of wire connecting port
Owner's Manual	1		(Be sure to hand over to customers)

Separate sold parts

Part name	Q'ty	Shape	Usage
Ceiling panel	1		Model: RB-B11MC(W)E

Parts to be procured locally

- Connecting pipe (Liquid side)
(6.4 mm (diam.), Nominal (diam.) 1/4" thick 0.8 mm)
- Connecting pipe (Gas side)
(9.5 mm (diam.), Nominal (diam.) 3/8" thick 0.8 mm)
RAS-M10SMUV-E, RAS-M10SMUCV-E, RAS-M13SMUV-E, RAS-M13SMUCV-E
(12.7 mm (diam.), Nominal (diam.) 1/2" thick 0.8 mm)
RAS-M16SMUV-E, RAS-M16SMUCV-E
- Power supply cord
2.5 mm² (H07RN-F or 60245IEC66)
- Connecting wire
1.0 mm² (H07RN-F or 60245IEC66)
- Thermal insulation for refrigerant pipe (10 mm or more, thermal insulating foam polyethylene)
- Thermal insulation for drain pipe (10 mm or more, foam polyethylene)
- Drain pipe (Outer 26 mm (diam.))
- Tapes
- Grounding wire (1.6 mm (diam.) or more)

3 SELECTION OF INSTALLATION PLACE

WARNING

- **The air conditioner must be installed in a location that can support the weight of the unit effectively.**
If the unit is not installed on a foundation that can support its weight effectively, the unit may fall down, resulting in possible human injury.
- **Where required ensure that the units installation is sufficient enough to withstand against an earthquake.**
An insufficient installation could result in the unit falling, causing possible human injury.
- **Install the air conditioner at a minimum height of 2.5 m from the floor.**
Do not insert your hands or others into the unit while the air conditioner is operating.

CAUTION

- Do not install the air conditioner in a location subject to a risk of exposure to a combustible gas.**
- If a combustible gas leaks and stays around the unit, a fire may occur.
- Upon approval of the customer, install the air conditioner in a place that satisfies the following conditions.**
- Place where the unit can be installed horizontally.
 - Place where a sufficient servicing space can be ensured for safety maintenance and check.
 - Place where drained water will not cause any problem.
- Avoid installing in the following places.**
- Place exposed to air with high salt content (seaside area), or place exposed to large quantities of sulfide gas (hot spring). (Should the unit be used in these places, special protective measures are needed.)
 - Place exposed to oil, vapor, oil smoke or corrosive gas.
 - Place where organic solvent is used nearby.
 - Place close to a machine generating high frequency.
 - Place where the discharged air blows directly into the window of the neighboring house. (For outdoor unit)
 - Place where noise of the outdoor unit is easily transmitted. (When installing the air conditioner on the boundary with the neighbor, pay due attention to the level of noise.)
 - Place with poor ventilation.
(Before air ducting work, check whether value of air volume, static pressure and duct resistance are correct.)

Installation space

Secure the specified space in the figure for installation and servicing.

Ensure there is sufficient space to install the unit and to perform maintenance work as and when required. Keep 15 mm or more for clearance between top plate of the indoor unit and the ceiling surface.

Installation space

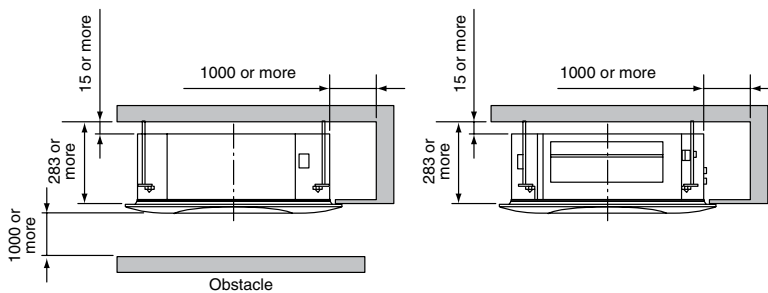

Selection of installation place

In case of continued operation of the indoor unit under high-humidity conditions as described below, dew may condense and water may drop.

Especially, high-humidity atmosphere (dew point temperature: 23°C or more) may generate dew inside the ceiling.

1. Unit is installed inside the ceiling with slated roof.
2. Unit is installed at a location using inside of the ceiling as fresh air intake path.
3. Kitchen

When installing a unit at such place, put insulating material (glass wool, etc.) additionally on all the positions of the indoor unit, which contact with high-humidity atmosphere.

ADVICE

Set a service check opening panel at right side of the unit (size: 450 × 450 mm or more) for piping, maintenance, and servicing.

Ceiling height

Model RAS-	Possible installed ceiling height
M10SMUV-E, M10SMUCV-E, M13SMUV-E, M13SMUCV-E	Up to 2.7 m
M16SMUV-E, M16SMUCV-E	Up to 3.5 m

When the height of the ceiling exceeds the distance of the item Standard in Table above, the hot air is difficult to reach the floor.

Therefore, it is necessary to change the setup value of the high ceiling switch. (RAS-M16SMUV-E and M16SMUCV-E only)

When changing the setting of the ceiling height in the models, RAS-M10SMUV-E, M10SMUCV-E, M13SMUV-E and M13SMUCV-E, if it is set over 2.7 m, the hot air is difficult to reach the floor.

How to set the High ceiling switch

- Remove the cover of the electric parts box by taking off the mounting screws (3 positions) and pushing the hooking section. (The cover of the electric parts box remains hanged to the hinge.)
- There are the selector switches (SW02) on the P.C. board of the electric parts box.
No.1 and No.2 of the selector switches (SW02) are provided to select the height of the ceiling.
According to the ceiling height in the following table, select No.1 or No.2 of the selector switches (SW02).

REMARK

- When using the high ceiling (1) or (2), cold air may be felt due to the temperature drop of discharge air.

Height list of ceiling possible to be installed

Model RAS-	M10SMUV-E M10SMUCV-E	M13SMUV-E M13SMUCV-E	M16SMUV-E M16SMUCV-E	SW02	
				No.1	No.2
Standard (Factory setting)	2.5 to 2.7 m	2.5 to 2.7 m	2.5 to 2.9 m	OFF	OFF
High ceiling (1)	—	—	2.9 to 3.2 m	ON	OFF
High ceiling (2)	—	—	3.2 to 3.5 m	ON	ON

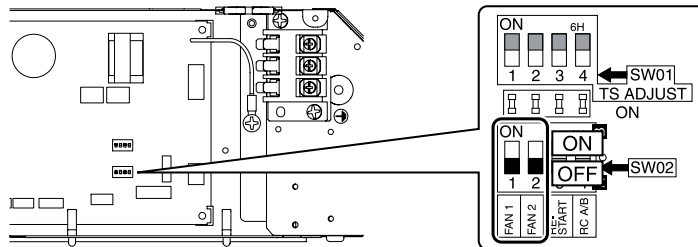

WARNING

Install the air conditioner certainly to sufficiently withstand the weight.
If the strength is insufficient, the unit may fall down resulting in human injury.
Perform a specified installation work to guard against an earthquake.
An incomplete installation can cause accidents by the units falling and dropping.

Remote controller

- Should be placed where there are no obstacles, such as curtains, that may block the signal.
- Do not install the remote controller in a place exposed to direct sunlight or close to a heating source such as a stove.
- Keep the remote controller at least 1 m away from the nearest TV set or stereo equipment. (This is necessary to prevent image disturbance or noise interference.)
- The location of the remote controller should be determined as shown the right.

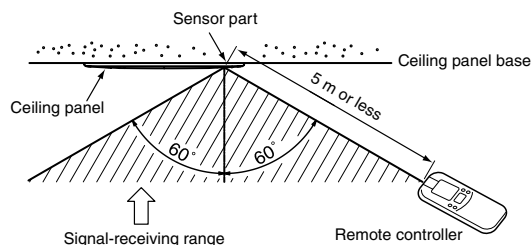

4 INSTALLATION OF INDOOR UNIT

WARNING

The installation of the air conditioning unit must be positioned in a location that can sufficiently support its weight and give protection against adverse environmental conditions. Failure to do so may result in unit damage and possible human injury. Any incomplete installation may also cause possible risk of human injury.

- Unpack the package, take out the product and then place it on the floor so that the same surface directs underneath as it is placed in the package.
- Never put the products in a pile or put weight on them, which are taken out from the packing box; otherwise there is a possibility to damage electric parts, fan parts, draining mechanism, and etc.
If the both sides are turned over, a deformation of mounting metal of the ceiling panel which is sold separately, etc. may be caused. Accordingly the product may be damaged and the installation becomes impossible in some cases.

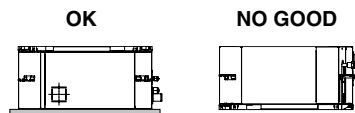

REQUIREMENT

Strictly comply with the following rules to prevent damage of the indoor units and human injury.

- Do not place heavy objects on the indoor unit. (Even when units are still packaged)
- Always carry the unit as packaged from the factory wherever possible. If carrying in the indoor unit unpacked by necessity, be sure to use buffering cloth, etc. to prevent damaging the unit.
- To move the indoor unit, hold the hanging brackets (4 positions) only. Do not apply force to other parts (refrigerant pipe, drain pan, foamed parts, or resin parts etc.).
- To be carried by two or more people. Do not strap the unit in positions other than stated.

Dimensional view

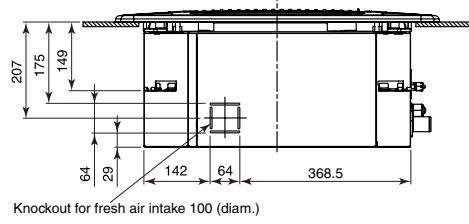
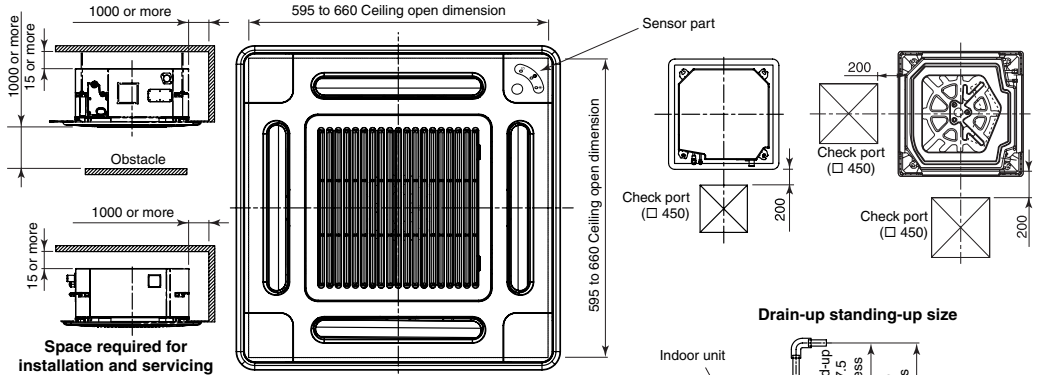

Drain-up standing-up size

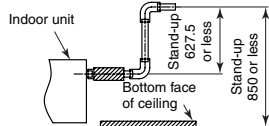

Note

As ABS is used for the drain discharge port of the main unit, the vinyl chlor paste cannot be used. Use the flexible hose (Band fix) included in the package.

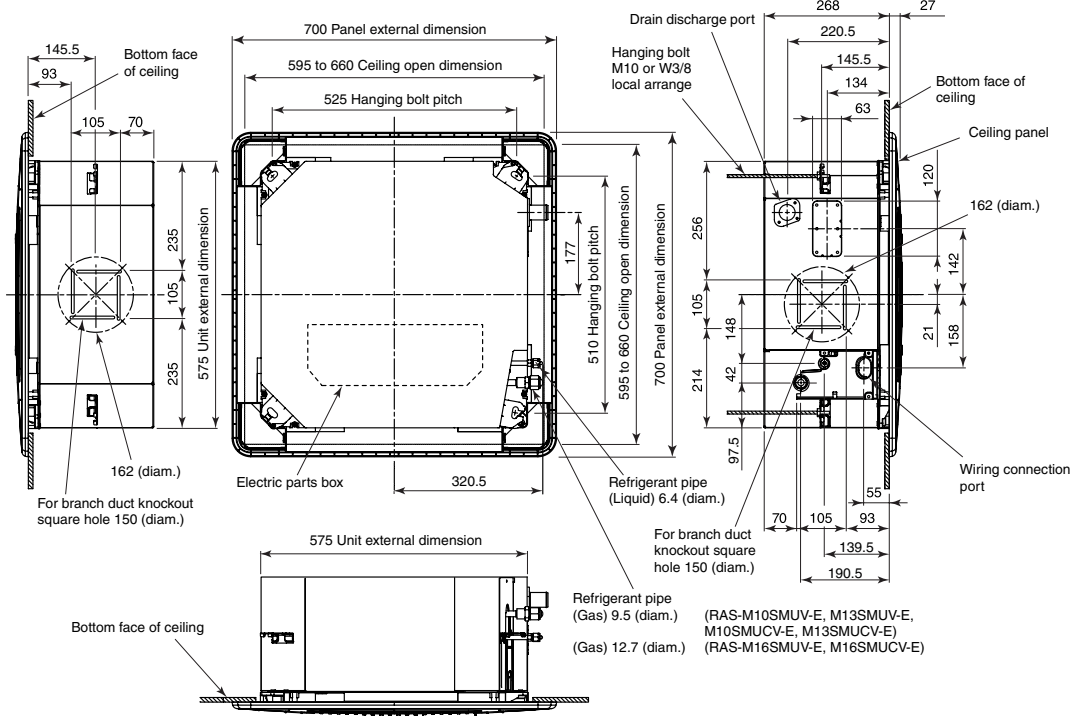

Ceiling opening and installation of hanging bolts

- Evaluate and determine the piping and wiring requirements inside the ceiling prior to the hanging of the unit.
- After installation place of the indoor unit has been determined, create opening in ceiling and install the hanging bolts.
- For the ceiling opening size and pitch for hanging bolts refer to the dimensional drawing and the supplied installation pattern.
- Once the ceiling void has been created, ensure that the drain pipe, refrigerant pipes, inter-connecting wires and all control wires are in place prior to installing the actual indoor unit.

Please procure the hanging bolts and nuts for installation of the indoor unit at local site.

Hanging bolt	M10 or W3/8	4 pieces
Nut	M10 or W3/8	12 pieces

How to use the supplied installation pattern

The installation pattern is enclosed within the packaging of the air conditioner.

Existing ceiling void

Use the pattern to determine the position and size of the opening and location of the hanging bolts.

New ceiling void

Use the pattern to determine the position of the new ceiling opening. Cut off slit section of the main unit of the installation pattern.

Cut off the outside of the pattern according to size of the ceiling opening. (There is a slit on the standard opening size section.)

- Install the indoor unit after installation of the hanging bolts.
- Using the supplied pattern attach it to the indoor unit using the supplied fixing screws (M5 × 16L 4 pieces). (Screw pattern to the ceiling panel hanging brackets of the indoor unit)
- When creating the opening ensure it is as per the outer dimensions of the supplied pattern.

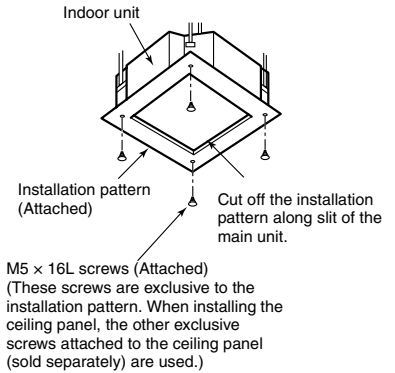

Opening a ceiling and installation of hanging bolts

Treatment of ceiling

The ceiling differs according to the structure of the building. For details, consult your architect.

In the process after the ceiling panels have been removed, it is important to reinforce the ceiling construction and ensure the ceiling remains in a horizontal position. This is to prevent possible vibration of the ceiling panels.

1. Cut and remove the ceiling material.
2. Reinforce the cut surface of the ceiling construction and add support for fixing the end of ceiling panel.

Installation of hanging bolt

Use M10 hanging bolts (4 pieces, locally procured).

When mounting the unit, set the pitch of the hanging bolts according to the size of the unit as detailed on the dimensional drawing.

New concrete slab

Install the bolts with insert brackets or anchor bolts.

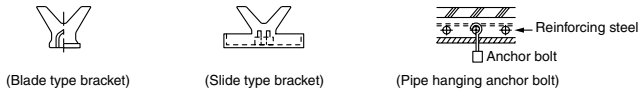

Steel frame structure

Use existing angles or install new support angles.

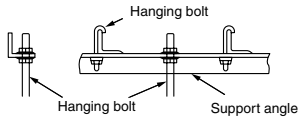

Existing concrete slab

Use a hole-in anchors, hole-in plugs, or a hole-in bolts.

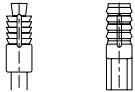

Installation of indoor unit

- Attach the nut (M10 or W3/8: Procured locally) and washer (34 mm (diam.)) to the hanging bolt.
- Put washers at either side of the T-groove on the hanging bracket of the indoor unit in order to hang the unit.
- Using a spirit level, check that all four sides are horizontal. (Horizontal positioned within 5 mm)
- Cut off the installation gauge from the installation pattern.
- Using the installation gauge, check and adjust clearance between the indoor unit and the ceiling opening (1) (10 to 42 mm on each side).

Ensure that the unit is level to the ceiling and within a distance of (2) 23 mm to 28 mm below.

The installation gauge has details of how to use printed on it.

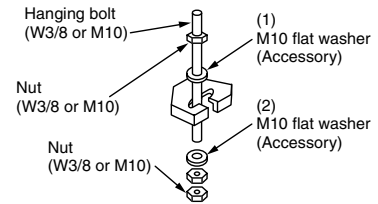

- (1) M10 washer supplied, all other material must be procured locally.
- (2) To ensure that the unit is mounted safely, the hanging bolt must be positioned just below the hanging bracket as shown in the diagram.

NOTE

Install the indoor unit so that the end part of opening does not come into contact with the drain socket piping.

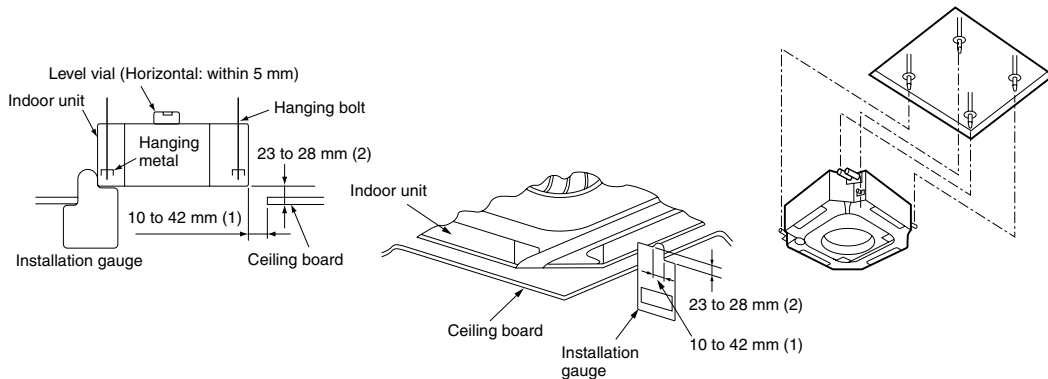

REQUIREMENT

Before installation of the indoor unit be sure to remove the transportation cushion found between the fan and the bell mouth. Running the unit without removing the cushion may damage the fan motor.

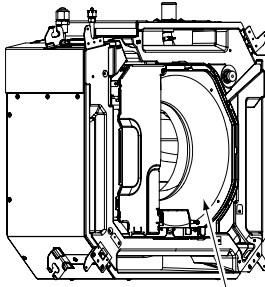

Be sure to remove the cushion for transportation between the fan and the bell mouth.

Installation of ceiling panel (Sold separately)

Install the ceiling panel after completion of the installation of the indoor unit, including all piping and wiring. Install the ceiling panel as per the supplied Installation Manual. Check the installation dimensions of the indoor unit and the ceiling opening are correct and then install.

REQUIREMENT

Ensure the ceiling panel is mated to the ceiling surface or the indoor unit. If the panel and unit are not mated together this may result in the formation of dew condensation causing a possible water leak. First remove the 4 corner caps from the ceiling panel and fit to the indoor unit.

5 DRAIN PIPING WORK

CAUTION

- Install the drain piping so that the water drains effectively.
- Apply heat insulation to prevent dew condensation from forming.
- Incorrectly installed pipework may result in a water leak.

Pipe material/Insulator and size

The following materials for piping work and insulation are to be procured locally.

Pipe material	Hard vinyl chloride pipe socket for VP25
	Hard vinyl chloride pipe VP25 (Outer diameter 32 mm (diam.))
Insulator	Foamed polyethylene foam, thickness: 10 mm or more

REQUIREMENT

- Ensure insulating of the drain pipes and connecting parts on the indoor units.
- The drain pipe should have a downward slope of at least 1/100 and ensure there are no swells or blockages as this will cause abnormal sounds.
- The maximum traverse length of drain pipe is 20 m. Provide support brackets at intervals of 1.5 to 2 m where necessary to prevent movement.
- Install the combined piping as shown in the illustration.
- Do not create an air purge in the pipework, as the water would leak from this point.

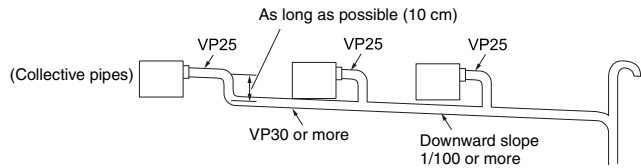
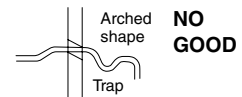
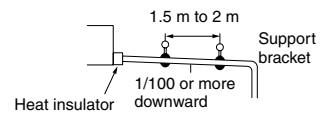

- The hard vinyl-chloride pipe cannot be connected directly to the drain pipe connecting port of the indoor unit. For connection with the drain pipe connecting port, ensure that the supplied flexible hose is fitted.
- Adhesive agent cannot be used for the pipe connecting port (hard socket) on the indoor unit. Be sure to use the supplied hose band for fixing, otherwise there is a risk of damage or water leakage from the drain pipe connecting port.

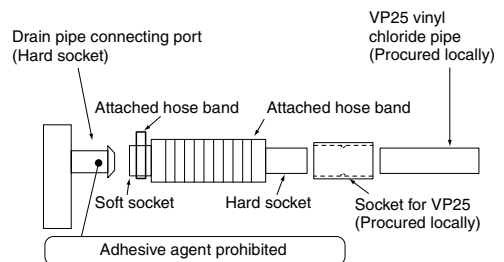

Connection of flexible hose

- Insert the soft socket of the supplied flexible hose into the connecting port of the drain pipe.
- Align the supplied hose band to the pipe connecting port end, and tighten.

REQUIREMENT

- Fix the soft socket with the supplied hose band, tighten at the upper position of the unit.
- The supplied flexible hose can bend up to a maximum of 45°.

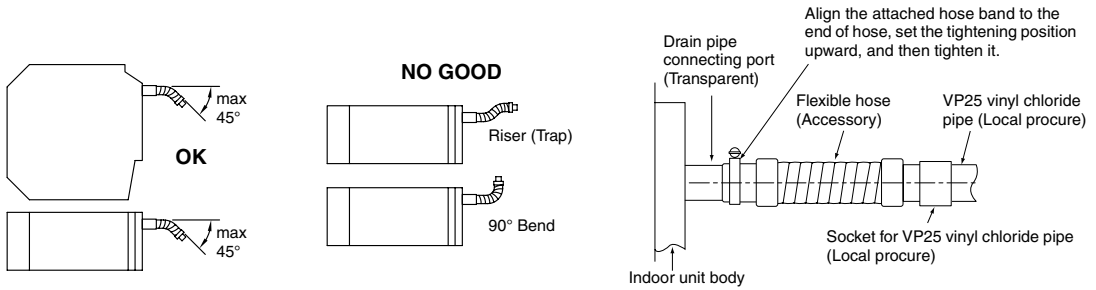

Connection of drain pipe

- Connect the hard socket (Procured locally) to the hard socket side of the supplied flexible hose which has been installed.
- Connect the drain pipes (Procured locally) in turn to the connected hard sockets.

REQUIREMENT

- Using an adhesive agent for vinyl chloride, connect the hard vinyl chloride pipes so that water does not leak.
- Allow sufficient time for the adhesive to set and harden. (Refer to the instructions of the adhesive.)

Drain up

When it is not possible to achieve a natural downward slope on the drain pipe, you can create a vertical lift (Drain up) on the pipe.

- Set the height of the drain pipe within 850 mm from the bottom surface of the ceiling.
- The drain pipe should be piped from the drain pipe connecting port horizontally for a maximum of 300 mm and then piped vertically.
- After piping the vertical lift, ensure the pipework is set to a downward gradient.

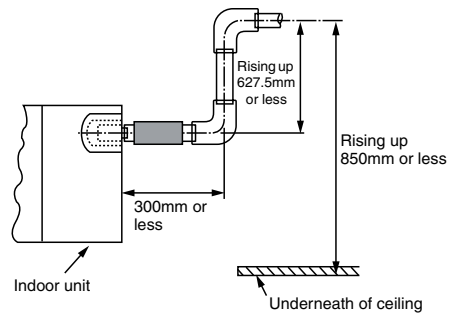

Check the draining

After completion of drain piping, check water drains away and that no water leaks from any of the connecting parts. At the same time check for any abnormal sounds from the drain pump. Ensure drainage is checked during cooling mode.

When the electric work has finished:

- Before installing the ceiling panel, pour water as shown in the following figure, check water drains from the drain pipe connecting port (Transparent) in COOL mode and then check there are no water leaks from the drain pipes.

When the electric work has not finished:

- Pull out the float switch connector (3P: Red) from P.C. board connector (CN34: Red) of the electric parts box. (Ensure the power is turned off.)
- Connect the single-phase 220-240V, 1N, 50 Hz power to the terminal blocks (1) and (2).
- Pour water referring to the figure. (Amount: 1500 cc to 2000 cc)
- When the power is turned on, the drain pump motor drives automatically.

Check water is drained from the drain pipe connecting port (Transparent), and then check there is no water leak from the drain pipes.

- After checking for water leaks on the drain, turn off the power supply, and re-attach the float switch connector to the original position (CN34) on the P.C. board and refit the electric parts box.

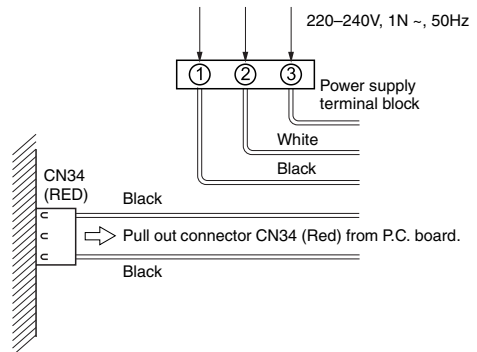

Thermal insulating process

- After checking the draining, wrap the supplied thermal insulation material for the drain connecting part around the flexible hose leaving no clearance from the root of the drain pipe connecting port of the indoor unit.
- Wrap the thermal insulation material (procured locally) around the drain pipe so that it piles up on the supplied the thermal insulation material for the drain connecting part, leaving no clearance.

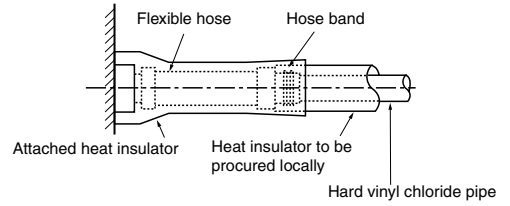

CAUTION

Ensure water is poured slowly.

If water is poured vigorously, it is scattered inside of the indoor unit resulting in a cause of unit trouble.

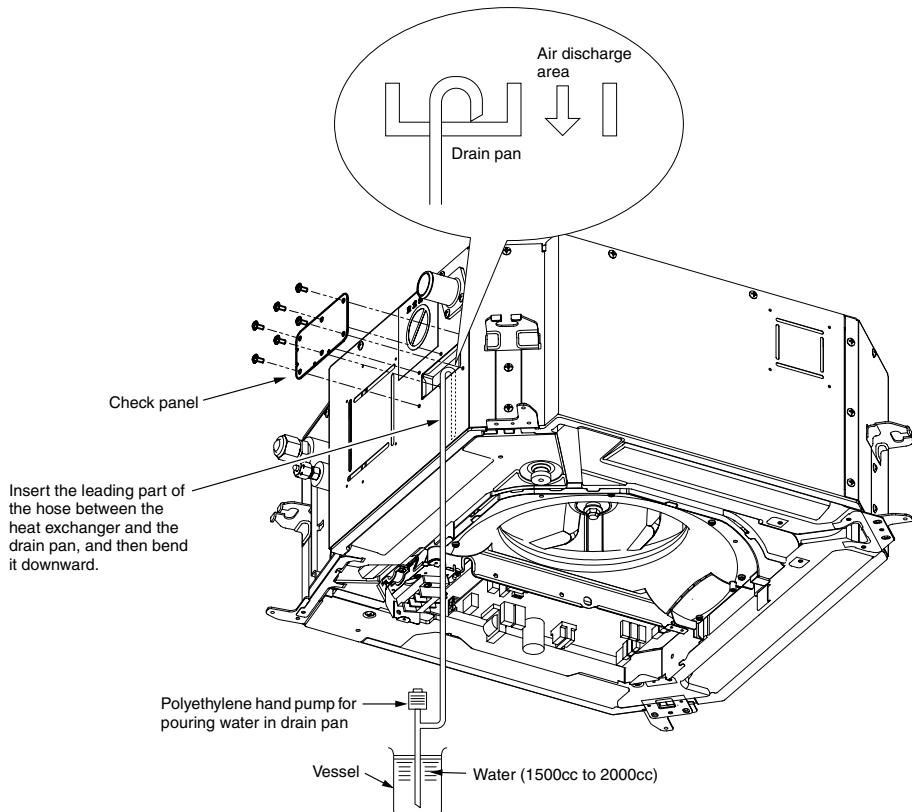

6 REFRIGERANT PIPING AND EVACUATING

Refrigerant piping

1. If the outdoor units are to be mounted on a wall, make sure that the supporting platform is sufficiently strong. The platform should be designed and manufactured to maintain its strength over a long period of time, and sufficient consideration should be given to ensuring that the outdoor unit will not fall.
2. Use copper pipe with 0.8 mm or more thickness.
3. Flare nut and flare works are different from those of the conventional refrigerant.
Take out the flare nut attached to the main unit of the air conditioner, and use it.

CAUTION

IMPORTANT 4 POINTS FOR PIPING WORK

1. Remove dust and moisture from the inside of the connecting pipes.
2. Tight connection (between pipes and unit)
3. Evacuate the air in the connecting pipes using VACUUM PUMP.
4. Check the gas leakage. (Connected points)

Permissible piping length and heat

They vary according to the outdoor unit.
For details, refer to the Installation Manual attached to the outdoor unit.

Flaring

Insert a flare nut into the pipe, and flare the pipe. As the flaring sizes of R410A differ from those of refrigerant R22, the flare tools newly manufactured for R410A are recommended.

However, the conventional tools can be used by adjusting projection margin of the copper pipe.

- Projection margin in flaring: B (Unit: mm)

Rigid (Clutch type)

Outer diameter of copper pipe	R410A tool used		Conventional tool used	
	R410A	R22	R410A	R22
6.4	0 to 0.5	(Same as left)	1.0 to 1.5	0.5 to 1.0
9.5	0 to 0.5	(Same as left)	1.0 to 1.5	0.5 to 1.0
12.7	0 to 0.5	(Same as left)	1.0 to 1.5	0.5 to 1.0

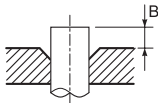

Imperial (Wing nut type)

Outer diameter of copper pipe	R410A	R22
6.4	1.5 to 2.0	1.0 to 1.5
9.5	1.5 to 2.0	1.0 to 1.5
12.7	2.0 to 2.5	1.5 to 2.0

- Flaring diam. meter size : A (Unit: mm)



Outer diameter of copper pipe	A ⁺⁰ / _{-0.4}	
	R410A	R22
6.4	9.1	9.0
9.5	13.2	13.0
12.7	16.6	16.2

* In the case of flaring for R410A with the conventional flare tool, pull it approx. 0.5 mm further out than that for R22 to adjust to the specified flare size. The copper pipe gauge is useful for adjusting the projection margin size.

Tightening connection

CAUTION

- Do not apply excessive torque. Otherwise, the nut may crack depending on the conditions.

(Unit: N·m)

Outer diameter of copper pipe	Tightening torque
6.4 mm (diam.)	14 to 18 (1.4 to 1.8 kgf·m)
9.5 mm (diam.)	33 to 42 (3.3 to 4.2 kgf·m)
12.7 mm (diam.)	50 to 62 (5.0 to 6.2 kgf·m)

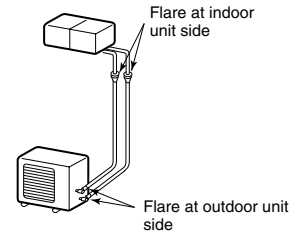

- Tightening torque of flare pipe connections.

Pressure of R410A is higher than that of R22. (Approx. 1.6 times) Therefore, using a torque wrench, tighten the flare pipe connecting sections which connect the indoor and outdoor units of the specified tightening torque. Incorrect connections may cause not only a gas leak, but also a trouble of the refrigeration cycle.

Align the centers of the connecting pipes and tighten the flare nut as far as possible with your fingers. Then tighten the nut with a spanner and torque wrench as shown in the figure.

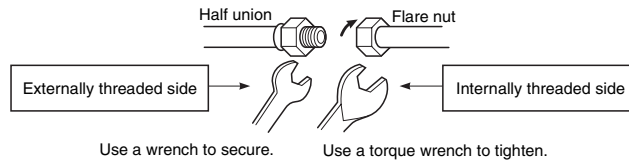

7 EVACUATING

EVACUATION

Evacuate the air in the connecting pipes and in the indoor unit using vacuum pump.
Do not use the refrigerant in the outdoor unit. For details, see the manual of vacuum pump.

Use a vacuum pump

Be sure to use a vacuum pump with counter-flow prevention function so that inside oil of the pump does not flow backward into pipes of the air conditioner when the pump stops.

1. Connect the charge hose from the manifold valve to the service port of the gas side packed valve.
2. Connect the charge hose to the port of vacuum pump.
3. Open fully the low pressure side handle of the gauge manifold valve.
4. Operate the vacuum pump to start for evacuating. Perform evacuating for about 35 minutes if the piping length is total 70 meters. (25 minutes for total 50 meters) (assuming a pump capacity of 27 liters per minute.)
Then confirm that the compound pressure gauge reading is -101 kPa (-76 cmHg).
5. Close the low pressure side valve handle of gauge manifold.
6. Open fully the valve stem of the packed valves (both sides of Gas and Liquid).
7. Remove the charging hose from the service port.
8. Securely tighten the caps on the packed valves.

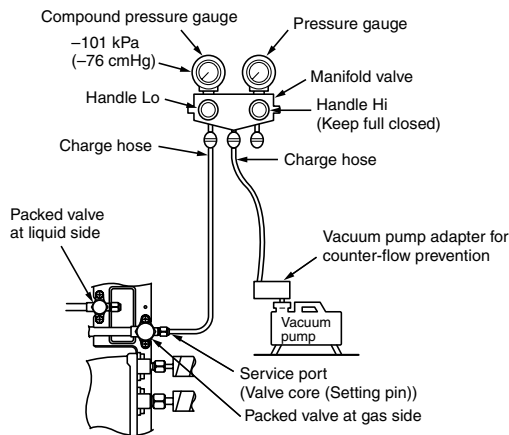

Packed valve handling precautions

- Open the valve stem until it touches the stopper. Once it is in contact with the stopper, refrain from applying any more force than is necessary.
- Securely tighten the valve stem cap in torque as follows:

Gas side (12.7 mm (diam.))	50 to 62 N·m (5.0 to 6.2 kgf·m)
Gas side (9.5 mm (diam.))	33 to 42 N·m (3.3 to 4.2 kgf·m)
Liquid side (6.4 mm (diam.))	14 to 18 N·m (1.4 to 1.8 kgf·m)
Service port	14 to 18 N·m (1.4 to 1.8 kgf·m)

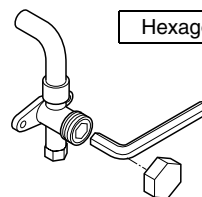

Hexagon wrench is required.

8 ELECTRICAL WORK

WARNING

1. **Using the specified wires, ensure to connect the wires, and fix wires securely so that the external tension to the wires do not affect the connecting part of the terminals.**
Incomplete connection or fixation may cause a fire, etc.
2. **Be sure to connect earth wire. (Grounding work)**
Do not connect the earth wire to gas pipe, city water pipe, lightning rod, or the earth wire of telephone. Incomplete grounding causes an electric shock.
3. **For electric work, strictly follow the Local Regulation in each country and the Installation Manual, and use an exclusive circuit.**
Capacity shortage of power circuit or incomplete installation may cause an electric shock or a fire.

CAUTION

- This indoor unit has no power cord.
- If incorrect/incomplete wiring is carried out, it will cause an electrical fire or smoke.
- Be sure to install an earth leakage breaker that is not tripped by shock waves.
If an earth leakage breaker is not installed, an electric shock may be caused.
- Be sure to use the cord clamps attached to the product.
- Do not damage or scratch the conductive core and inner insulator of power and inter-connecting wires when peeling them.
- Be sure to comply with local regulations on running the wire from outdoor unit to indoor unit (size of wire and wiring method etc.)
- Use the power cord and Inter-connecting cable of specified thickness, type, and protective devices required.

REQUIREMENT

- Appliance shall be installed in accordance with national wiring regulations.
- For wiring of power supply of the outdoor units, follow the Installation Manual of each outdoor unit.
- Perform the electric wiring so that it does not come to contact with the high-temperature part of the pipe. The coating may melt resulting in an accident.
- After connecting wires to the terminal blocks, provide a trap and fix wires with the cord clamp.
- Run the refrigerant piping line and control wiring line in the same line.
- Do not turn on the power of the indoor unit until vacuuming of the refrigerant pipes completes.

How to wire

1. Connect the connecting wire to the terminal as identified with their respective numbers on the terminal block of indoor and outdoor unit.
1.0 mm² (H07 RN-F or 60245 IEC 66)
2. Insulate the unsheathed redundant cords (conductors) with electrical insulation tape.
Process them so that they do not touch any electrical or metal parts.
3. For inter-unit wiring, do not use a wire jointed to another on the way.

Wire connection

REQUIREMENT

- Be sure to connect the wires matching the terminal numbers. Incorrect connection causes a trouble.
 - Be sure to pass the cables through the bushing of wiring connection port of the indoor unit.
 - Keep a margin (Approx. 100mm) on a wire to hang down the electric parts box at servicing, etc.
-
- Remove the cover of the electric parts box by taking off the mounting screws (3 positions) and pushing the hooking section. (The cover of the electric parts box remains hanged to the hinge.)
 - Connect the indoor/outdoor connection wires to the terminal block of the electric parts box. (Do not apply tension to the connecting section of the terminal block.)
 - Tighten the screws of the terminal block, and fix the wires with cord clamp attached to the electric parts box. (Do not apply tension to the connecting section of the terminal block.)
 - Using the attached thermal insulation material, seal the pipe connecting port. Otherwise, dewing may be caused.
 - Mount the cover of the electric parts box without pinching wires. (Mount the cover after cabling on the ceiling panel.)

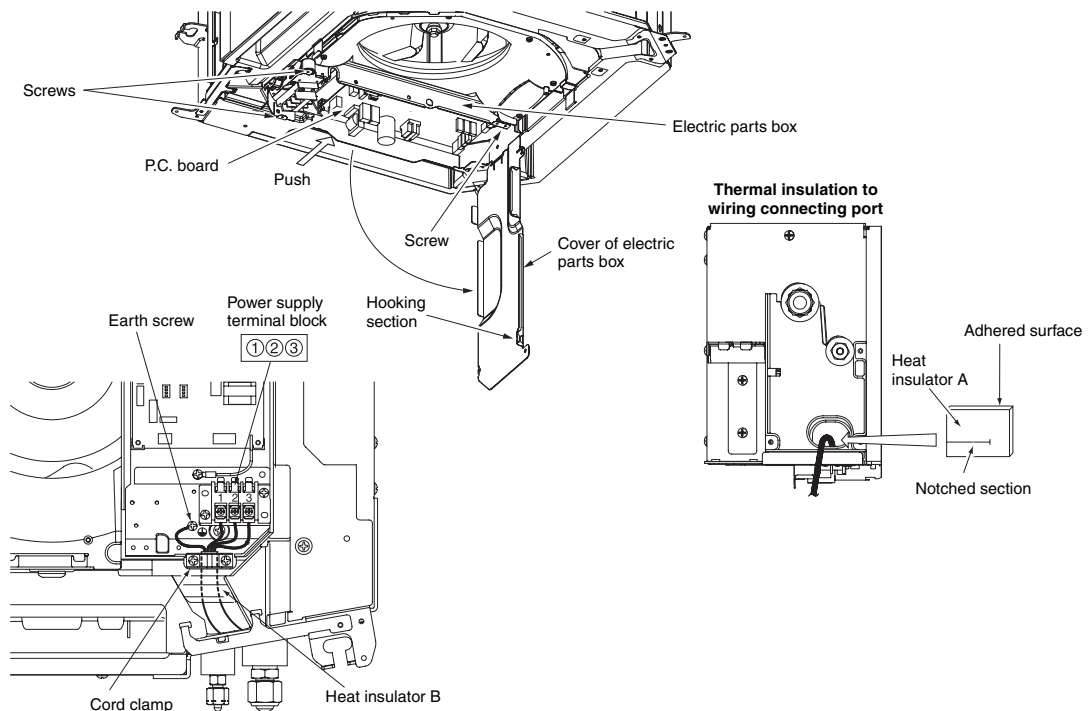

Wiring on the ceiling panel

According to the Installation Manual for the ceiling panel, connect the connectors to the P.C. board in the electric parts box.

Connect the sensor connector to CN201 (Blue), and the louver motor wiring connector to CN33 (White) on the P.C. board, respectively.

Draw and pass the sensor lead wire upper the louver motor wiring, and then close cover of the electric parts box. Perform the wiring work so that the electric parts box does not pinch the sensor lead wire.

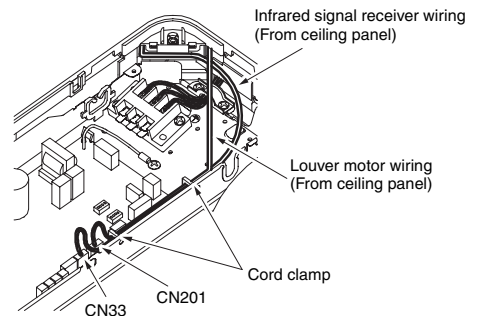

Wiring

1. Remove a screw and then remove cover of the electric parts box.
2. Strip wire ends (10 mm).
3. Match wire colors with terminal numbers on indoor and outdoor units' terminal blocks and firmly screw wires to the corresponding terminals.
4. Connect the ground wires to the corresponding terminals.
5. Fix the wires with cord clamp.
6. Fix cover of the parts box and the terminal block surely with the fixing screws.

Make a loop on the wire for margin of the length so that the electric parts box can be taken out during servicing.

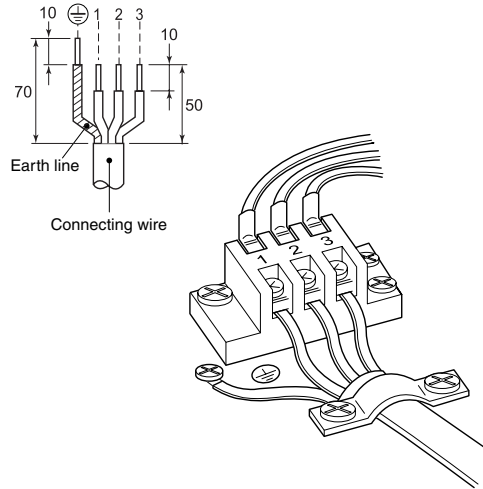

NOTE

Wire type: 1.0 mm² (H07RN-F or 60245IEC66)

Wiring diagram

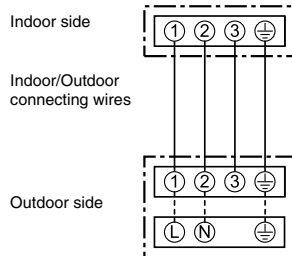

9 APPLICABLE CONTROLS

Remote controller selector switch setting

- If two indoor units are installed in the same room or adjoining rooms, when the user tries to operate only one unit, both units may receive the same remote controller signal and operate. This can be prevented by changing one of the indoor units and remote controllers to setting "B" (The default setting for both units is "A").
 - If the indoor unit and remote controller settings are different, the remote controller signal will not be accepted.
1. **Setting the remote controller**
 - Remove the cover, and insert the batteries.
 - Push the "CHECK" point and "MODE" button at once, for changing remote controller setting from "A" to "B". (Priority is given to "A" setting.)
 2. **Setting the unit**
 - Remove the cover of the electric parts box by taking off the mounting screws (3 positions) and pushing the hooking section. (The cover of the electric parts box remains hanged to the hinge.)
 - There are the selector switches (SW02) on the P.C. board of the electric parts box.
No.4 of the selector switches (SW02) is provided to select the switch of the remote controller.
Select ON of No.4 of the selector switches (SW02). (OFF: A setting, ON: B setting)

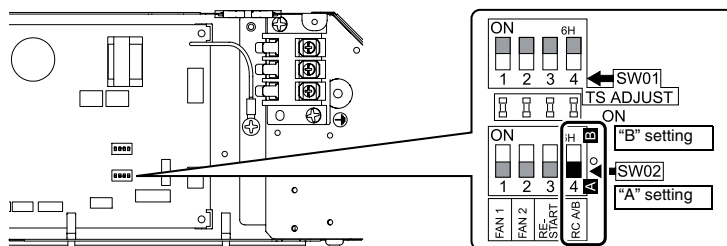

- Check whether the changed remote controller can operate the indoor unit or not.

Auto restart setting

This product is designed so that, after a power failure, it can restart automatically in the same operating mode as before the power failure.

INFORMATION

The product was shipped with Auto Restart function in the OFF position. Turn it ON as required.

How to set the Auto Restart

- Remove the cover of the electric parts box by taking off the mounting screws (3 positions) and pushing the hooking section. (The cover of the electric parts box remains hanged to the hinge.)
- There are the selector switches (SW02) on the P.C. board of the electric parts box.
No.3 of the selector switches (SW02) is provided for the selector switch. Select ON of No.3 of the selector switches (SW02). (OFF: setting without Auto Restart, ON: setting with Auto Restart)

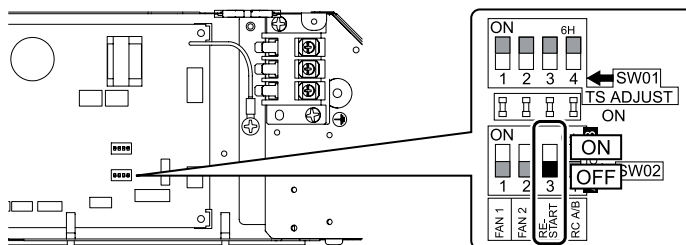

To improve Cooling/Heating effect

When only poor cooling/heating effect is obtained due to installation place of the indoor unit or construction of the room, the detection temperature of cooling/heating can be changed.

- Remove the cover of the electric parts box by taking off the mounting screws (3 positions) and pushing the hooking section. (The cover of the electric parts box remains hanged to the hinge.)
- There are the selector switches (SW01) on the P.C. board of the electric parts box.

The setting of the detection temperature can be changed by combining No.1 to No.4 switches of the selector switches (SW01). Adjust the setting of the detection temperature according to the table below.

No.1	No.2	No.3	No.4	COOL/DRY (°C)	HEAT (°C)
OFF	OFF	OFF	OFF	-2	-2
ON	OFF	OFF	OFF	-2	+4
OFF	ON	OFF	OFF	-2	+2
ON	ON	OFF	OFF	-2	0
OFF	OFF	ON	OFF	+4	-2
ON	OFF	ON	OFF	+4	+4
OFF	ON	ON	OFF	+4	+2
ON	ON	ON	OFF	+4	0
OFF	OFF	OFF	ON	+2	-2
ON	OFF	OFF	ON	+2	+4
OFF	ON	OFF	ON	+2	+2
ON	ON	OFF	ON	+2	0
OFF	OFF	ON	ON	0	-2
ON	OFF	ON	ON	0	+4
OFF	ON	ON	ON	0	+2
ON	ON	ON	ON	0	0

← Factory setting

Setting at shipment

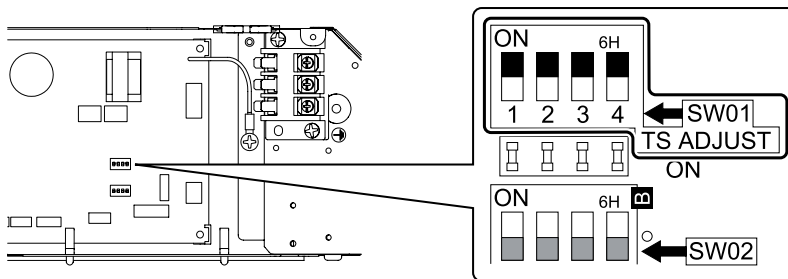

10 TEST OPERATION

Check and test operation

Be sure to test the piping connections for gas leak.

- Check the flare nut connections, valve stem cap connections and service port cap connections for gas leak with a leak detector or soap water.

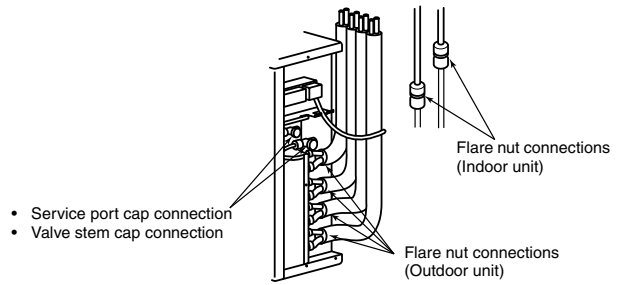





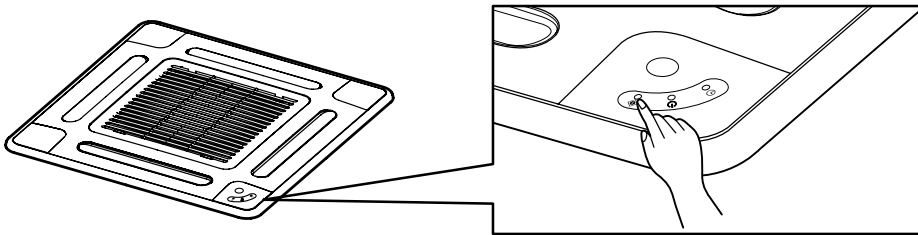



Test operation

- To test the system, push and hold RESET button for 10 sec. (There will be one short beep.)



11 INSTALLATION/SERVICING TOOLS

Tools

Tools	Applicable to R22 model	Tools	Applicable to R22 model
Gauge manifold	×		Flare tool (clutch type) <input type="checkbox"/> 
Charge hose	×		Gauge for projection adjustment <input type="checkbox"/> 
Electronic balance for refrigerant charging	<input type="checkbox"/>		Vacuum pump adapter <input type="checkbox"/> 
Torque wrench (nominal diam. 1/2, 5/8)	×		Gas leakage detector <input checked="" type="checkbox"/> 

× : Newly prepared (They are special requirements for R410A, separated from those for R22.)

: Existing tools are available.

For the details of the tools, refer to the Installation manual of the outdoor unit.

12 MAINTENANCE

Prior to maintenance, ensure the power supply is turned off.

WARNING

Cleaning of the air filter and other parts of the air filter involves dangerous work in high places, so be sure to have a qualified service person do it. Do not attempt it yourself.

CAUTION

Do not handle the buttons with wet hands as this will cause the risk of electric shock.

Cleaning of air filter

Clean the air filters every 3 months. The performance of the air conditioner will degrade if the air filters are covered with dust. Clean the air filters as often as possible.

- 1 Open the air inlet grille.**
 - Slide the air inlet grille buttons to detach the air inlet grille from the main ceiling panel. Lower the grille slowly whilst holding.
- 2 Take out the air filter.**
 - Push the extrusion of the air filter away from the grille and remove.
- 3 Cleaning with water or vacuum cleaner**
 - If dirt is heavy, clean the air filter using tepid water with a neutral detergent or just water.
 - After cleaning with water, dry the air filter sufficiently in a shaded place.
- 4 Mount the air filter.**
- 5 Close the air inlet grille.**
 - Close the air inlet grille, slide the button to locate into the ceiling panel fixing securely.

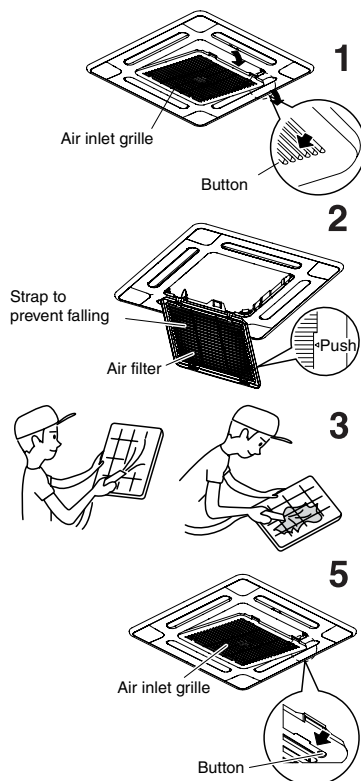

Cleaning of air outlet louver

The air outlet louver can be removed to clean if necessary.

- 1 Remove the air outlet louver.**
 - Holding both ends of the air outlet louver, remove it by sagging the center downwards.
- 2 Clean the air outlet louver with water.**
 - If dirt is heavy, clean the air outlet louver using tepid water with neutral detergent or just water.
- 3 Mount the air outlet louver.**
 - First push in the one side, and insert the opposite side by sagging the center downwards.

Be careful to insert the louver in the correct direction.

Insert the louver with the printed mark facing upwards, and the arrow on the louver pointing in the outward direction.

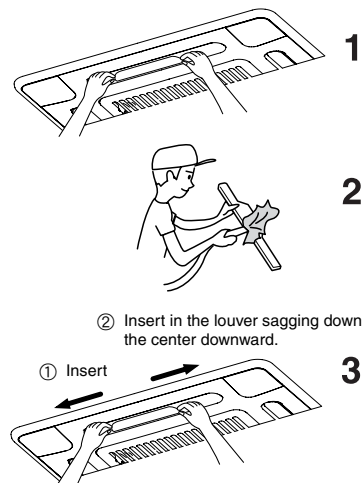

TOSHIBA CARRIER CORPORATION