

Air conditioner

Installation manual

AC***RN*DKG

- Thank you for purchasing this Samsung air conditioner.
- Before operating this unit, please read this manual carefully and retain it for future reference.



DB68-08131A-01

SAMSUNG

Contents

Safety Information	3
Installation Procedure	5
Step 1 Checking and preparing accessories	5
Step 2 Choosing the installation location	5
Step 3 Optional: Insulating the body of the indoor unit	12
Step 4 Installing the indoor unit	12
Step 5 Purging inert gas from the indoor unit	14
Step 6 Cutting and flaring the pipes	14
Step 7 Connecting the assembly pipes to the refrigerant pipes	15
Step 8 Performing the gas leak test	16
Step 9 Insulating the refrigerant pipes	16
Step 10 Installing the drain hose and drain pipe	17
Step 11 Performing the drainage test	18
Step 12 Optional: Installing DPM	18
Step 13 Optional: Installing external controller	19
Step 14 Connecting the power and communication cables	19
Step 15 Optional: Extending the power cable	21
Step 16 Setting additional functions of wired remote control	22
Step 17 Setting the indoor unit option code	25
Step 18 Setting indoor unit addresses and installation options	26
Appendix	31
Troubleshooting	31

Safety Information

WARNING

- Hazards or unsafe practices that may result in severe personal injury or death.

CAUTION

- Hazards or unsafe practices that may result in minor personal injury or property damage.
- Carefully follow the precautions listed below because they are essential to guarantee the safety of the equipment.

WARNING

- Always disconnect the air conditioner from the power supply before servicing it or accessing its internal components.
- Verify that installation and testing operations are performed by qualified personnel.
- Verify that the air conditioner is not installed in an easily accessible area.

General information

WARNING

- Carefully read the content of this manual before installing the air conditioner and store the manual in a safe place in order to be able to use it as reference after installation.
- For maximum safety, installers should always carefully read the following warnings.
- Store the operation and installation manual in a safe location and remember to hand it over to the new owner if the air conditioner is sold or transferred.
- This manual explains how to install an indoor unit with a split system with two SAMSUNG units. The use of other types of units with different control systems may damage the units and invalidate the warranty. The manufacturer shall not be responsible for damages arising from the use of non compliant units.
- The manufacturer shall not be responsible for damage originating from unauthorized changes or the improper connection of electric and requirements set forth in the "Operating limits" table, included in the manual, shall immediately invalidate the warranty.
- The air conditioner should be used only for the

applications for which it has been designed: the indoor unit is not suitable to be installed in areas used for laundry.

- Do not use the units if damaged. If problems occur, switch the unit off and disconnect it from the power supply.
- In order to prevent electric shocks, fires or injuries, always stop the unit, disable the protection switch and contact SAMSUNG's technical support if the unit produces smoke, if the power cable is hot or damaged or if the unit is very noisy.
- Always remember to inspect the unit, electric connections, refrigerant tubes and protections regularly. These operations should be performed by qualified personnel only.
- The unit contains moving parts, which should always be kept out of the reach of children.
- Do not attempt to repair, move, alter or reinstall the unit. If performed by unauthorized personnel, these operations may cause electric shocks or fires.
- Do not place containers with liquids or other objects on the unit.
- All the materials used for the manufacture and packaging of the air conditioner are recyclable.
- The packing material and exhaust batteries of the remote controller(optional) must be disposed of in accordance with current laws.
- The air conditioner contains a refrigerant that has to be disposed of as special waste. At the end of its life cycle, the air conditioner must be disposed of in authorised centres or returned to the retailer so that it can be disposed of correctly and safely.
- Do not use means to accelerate the defrost operation or to clean, other than those recommended by Samsung.
- Do not pierce or burn.
- Be aware that refrigerants may not contain an odour.

Installing the unit

WARNING

IMPORTANT: When installing the unit, always remember to connect first the refrigerant tubes, then the electrical lines.

- Always disassemble the electric lines before the refrigerant tubes.

Safety Information

- Upon receipt, inspect the product to verify that it has not been damaged during transport. If the product appears damaged, DO NOT INSTALL it and immediately report the damage to the carrier or retailer (if the installer or the authorized technician has collected the material from the retailer.)
- After completing the installation, always carry out a functional test and provide the instructions on how to operate the air conditioner to the user.
- Do not use the air conditioner in environments with hazardous substances or close to equipment that release free flames to avoid the occurrence of fires, explosions or injuries.
- Our units should be installed in compliance with the spaces shown in the installation manual, to ensure accessibility from both sides and allow repairs or maintenance operations to be carried out. The unit's components should be accessible and easy to disassemble without endangering people and objects. For this reason, when provisions of the installation manual are not complied with, the cost required to access and repair the units (in SAFETY CONDITIONS, as set out in prevailing regulations) with harnesses, ladders, scaffolding or any other elevation system will NOT be considered part of the warranty and will be charged to the end customer.
- Auxiliary devices which may be a potential ignition source shall not be installed in the duct work.
- Verify that the air conditioner is connected to the power supply in accordance with the instructions provided in the wiring diagram included in the manual.
- Always verify that electric connections (cable entry, section of leads, protections...) are compliant with the electric specifications and with the instructions provided in the wiring scheme. Always verify that all connections comply with the standards applicable to the installation of air conditioners.
- Devices disconnected from the power supply should be completely disconnected in the condition of overvoltage category.
- Be sure not to perform power cable modification, extension wiring, and multiple wire connection.
 - It may cause electric shock or fire due to poor connection, poor insulation, or current limit override.
 - When extension wiring is required due to power line damage, refer to "**Step 15 Optional: Extending the power cable**" in the installation manual.

CAUTION

Make sure that you earth the cables.

- Do not connect the earth wire to the gas pipe, water pipe, lighting rod or telephone wire. If earthing is not complete, electric shock or fire may occur.

Install the circuit breaker.

- If the circuit breaker is not installed, electric shock or fire may occur.

Make sure that the condensed water dripping from the drain hose runs out properly and safely.

Install the power cable and communication cable of the indoor and outdoor unit at least 1m away from the electric appliance.

Install the indoor unit away from lighting apparatus using the ballast.

- If you use the wireless remote control, reception error may occur due to the ballast of the lighting apparatus.

Do not use the indoor unit for preservation of food items, plants, equipment, and art works. This may cause deterioration of their quality.

Do not install the indoor unit if it has any drainage problem.

Power supply line, fuse or circuit breaker







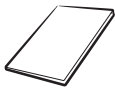

WARNING

- Always make sure that the power supply is compliant with current safety standards. Always install the air conditioner in compliance with current local safety standards.
- Always verify that a suitable grounding connection is available.
- Verify that the voltage and frequency of the power supply comply with the specifications and that the installed power is sufficient to ensure the operation of any other domestic appliance connected to the same electric lines.
- Always verify that the cut-off and protection switches are suitably dimensioned.

Installation Procedure

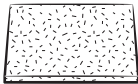
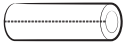
Step 1 Checking and preparing accessories

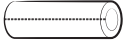
The following accessories are supplied with the indoor unit. The type and quantity may differ, depending on the specifications.

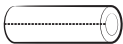
User manual (1) 	Installation manual (1) 
Clamp hose (1) 	Flexible hose (1) 
Insulation drain (1) 	Thermal insulation sponge A (1) 
Cable-tie (8) 	Thermal insulation sponge B (1) 
Rubber (8) 	Thermal insulation sponge C (1) 

Step 2 Choosing the installation location

Installation location requirements

- There must be no obstacles near the air inlet and outlet.
- Install the indoor unit on a ceiling that can support its weight.
- Maintain sufficient clearance around the indoor unit.
- Before installing the indoor unit, be sure to check whether the chosen location is well-drained.
- The indoor unit must be installed such that it is beyond public access and is not touchable by users.

WARNING

- If appliances contain R-32 refrigerant, then the floor area of the room in which the appliances are installed, operated and stored must be larger than the minimum floor area defined in table below A (m²).

Minimum required room area (A, m ²)	
m (kg)	Ceiling-mounted type
≤ 1.842	No requirement
1.843	3.64
1.9	3.75
2.0	3.95
2.2	4.34
2.4	4.74
2.6	5.13
2.8	5.53
3.0	5.92
3.2	6.48
3.4	7.32
3.6	8.20
3.8	9.14
4.0	10.1
4.2	11.2
4.4	12.3
4.6	13.4
4.8	14.6
5.0	15.8
5.2	17.1

- m : Total refrigerant charge in the system
- A : Minimum required room area

Installation Procedure

- IMPORTANT: it's mandatory to consider either the table 1 or taking into consideration the local law regarding the minimum living space of the premises.
- Minimum installation height of indoor unit is 0.6 m for floor mounted, 1.8 m for wall, 2.2 m for ceiling.

⚠ CAUTION

Do not install the air conditioner in following places.

- The place where there is mineral oil or arsenic acid. Resin parts flame and the accessories may drop or water may leak. The capacity of the heat exchanger may reduce or the air conditioner may be out of order.
- The place where corrosive gas such as sulfurous acid gas generates from the vent pipe or air outlet. The copper pipe or connection pipe may corrode and refrigerant may leak.
- The place where there is a machine that generates electromagnetic waves. The air conditioner may not operate normally due to control system.
- The place where there is a danger of existing combustible gas, carbon fiber or flammable dust.
- The place where thinner or gasoline is handled. Gas may leak and it may cause fire.

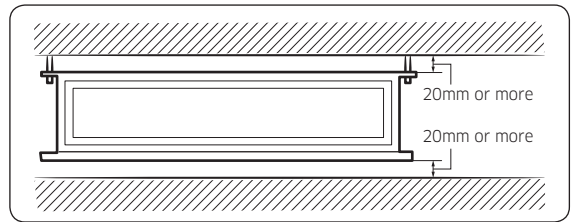

- You must have 20 mm or more space between the ceiling and the bottom of indoor unit. Otherwise, the noise from the vibration of indoor unit may bother the user. When the ceiling is under construction, the hole for check-up must be made to take service, clean and repair the unit.
- It is possible to install the unit at an height of between 2.2~2.5 m from the ground, if the unit has a duct with a well defined length (300 mm or more), to avoid fan motor blower contact.
- If you install the cassette or duct type indoor unit on the ceiling with humidity over 80%, you must apply extra 10 mm of polyethylene foam or other insulation with similar material on the body of the indoor unit.

Space requirements for installation

Construction Standard for Inspection Hole

- 1 In case, the ceiling is tex tile, Inspection hole dose not need.
- 2 In case, the ceiling is plaster board, Inspection hole depends on Inside height of the ceiling.
 - a Height is more than 0.5m : Only "B" [Inspection for PBA] is applied.
 - b Height is less than 0.5m : Both "A"&"B" are applied.
 - c "A"&"B" are inspection holes .

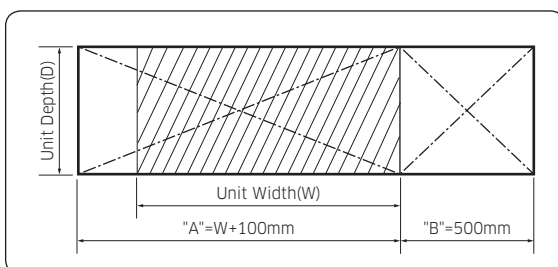

Indoor unit dimensions

AC026RNLDKG, AC035RNLDKG

(Unit: mm)

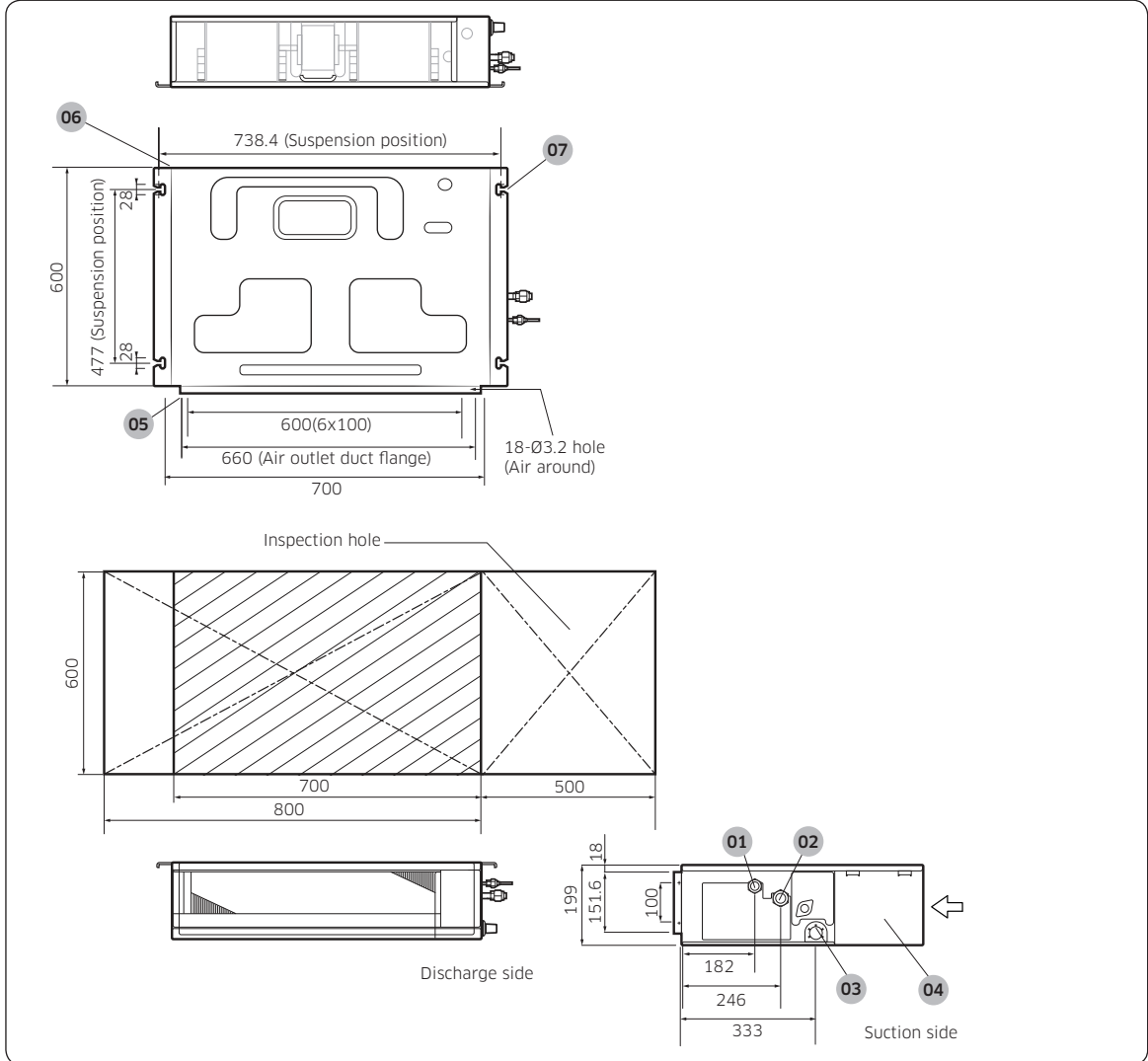

No.	Name	Description
01	Liquid pipe connection	ø6.35(1/4")
02	Gas pipe connection	ø9.52(3/8")
03	Drain pipe connection	OD25 ID20(without drain pump)
04	Power supply connection	
05	Air discharge flange	
06	Air filter	
07	Hook	M8~M10

Installation Procedure

AC052RNLDKG, AC071RNLDKG

(Unit: mm)

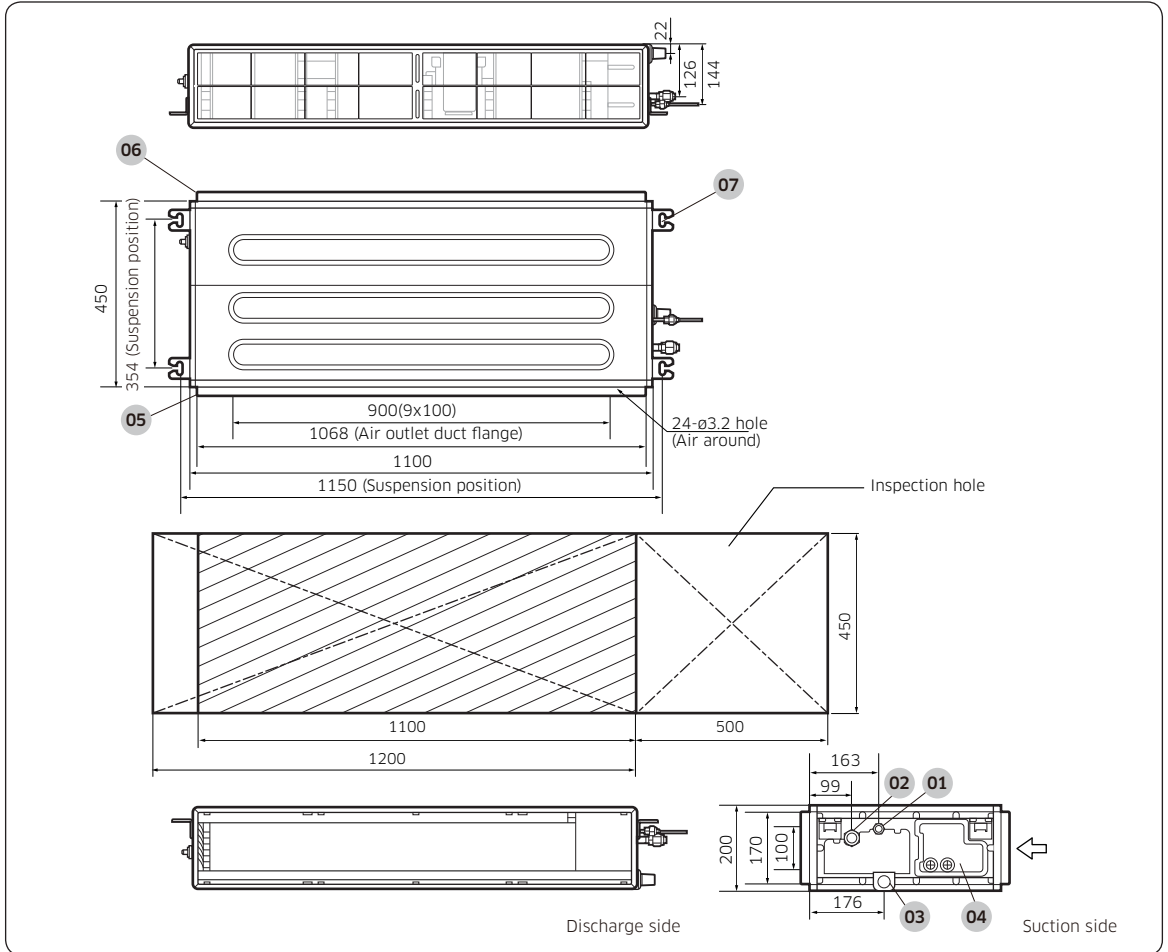

No.	Name	Description
01	Liquid pipe connection	ϕ 6.35(1/4")
02	Gas pipe connection	**052**: ϕ 12.70(1/2"); **071**: ϕ 15.88(5/8")
03	Drain pipe connection	OD25 ID20(without drain pump)
04	Power supply connection	
05	Air discharge flange	
06	Air filter	
07	Hook	M8~M10

AC035RNMDKG, AC052RNMDKG, AC071RNMDKG

(Unit: mm)

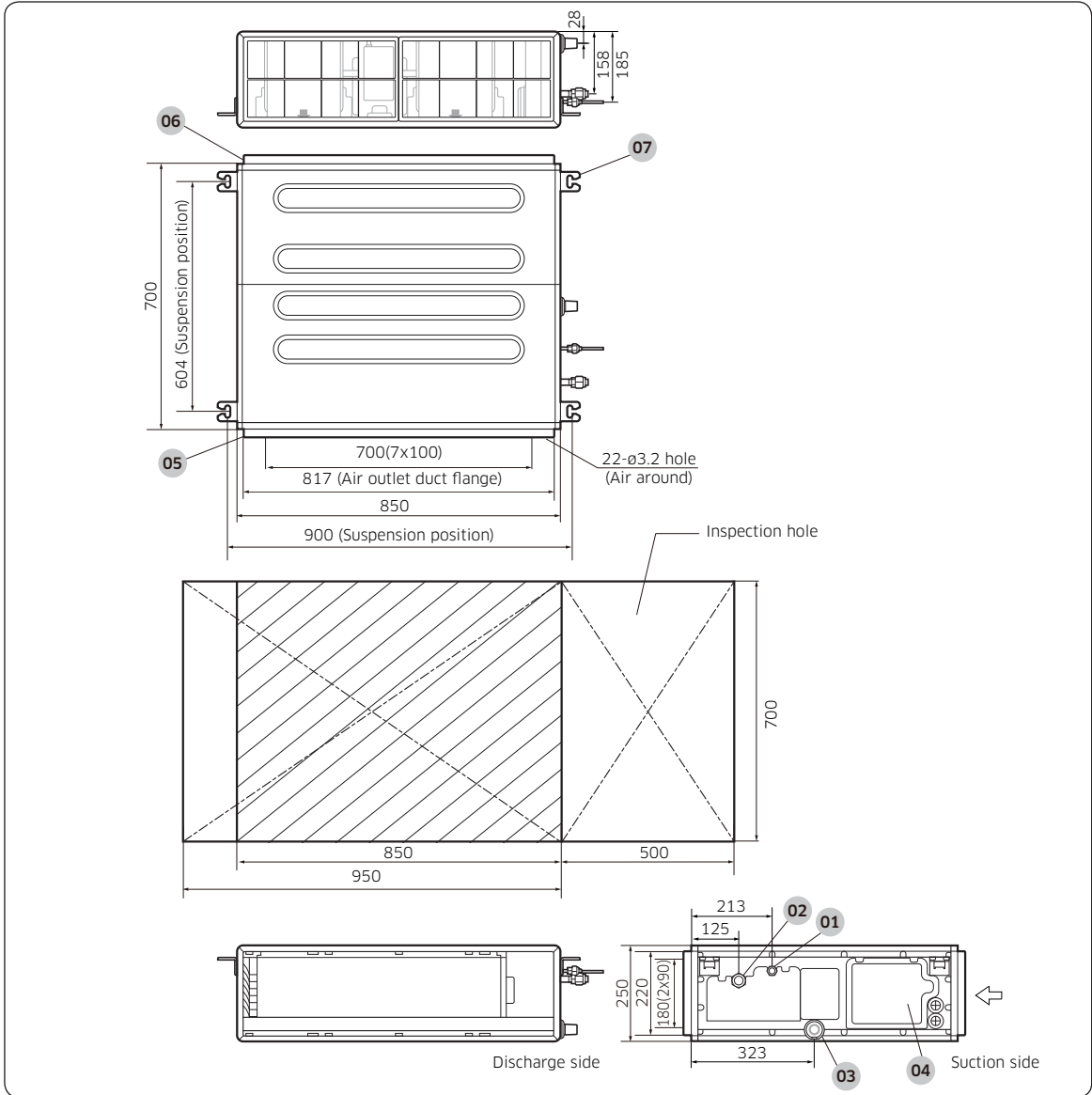

No.	Name	Description
01	Liquid pipe connection	ø6.35(1/4")
02	Gas pipe connection	**035**: ø9.52(3/8"); **052**: ø12.70(1/2") **071**: ø15.88(5/8")
03	Drain pipe connection	OD25 ID20(without drain pump)
04	Power supply connection	
05	Air discharge flange	
06	Air filter	
07	Hook	M8~M10

Installation Procedure

AC100RNMDKG

(Unit: mm)

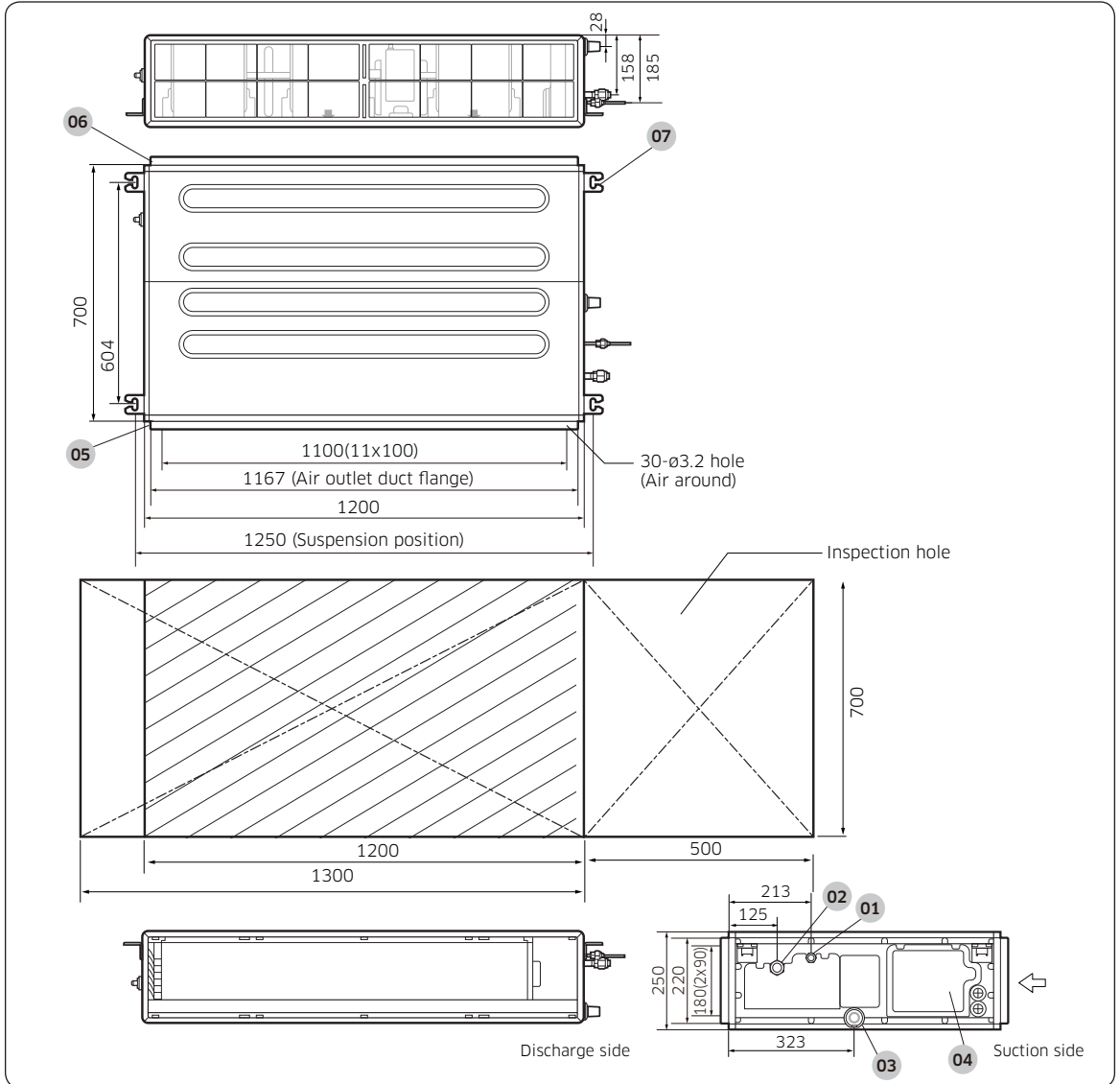

No.	Name	Description
01	Liquid pipe connection	ø9.52(3/8")
02	Gas pipe connection	ø15.88(5/8")
03	Drain pipe connection	OD25 ID20(without drain pump)
04	Power supply connection	
05	Air discharge flange	
06	Air filter	
07	Hook	M8~M10

AC120RNMDKG, AC140RNMDKG

(Unit: mm)

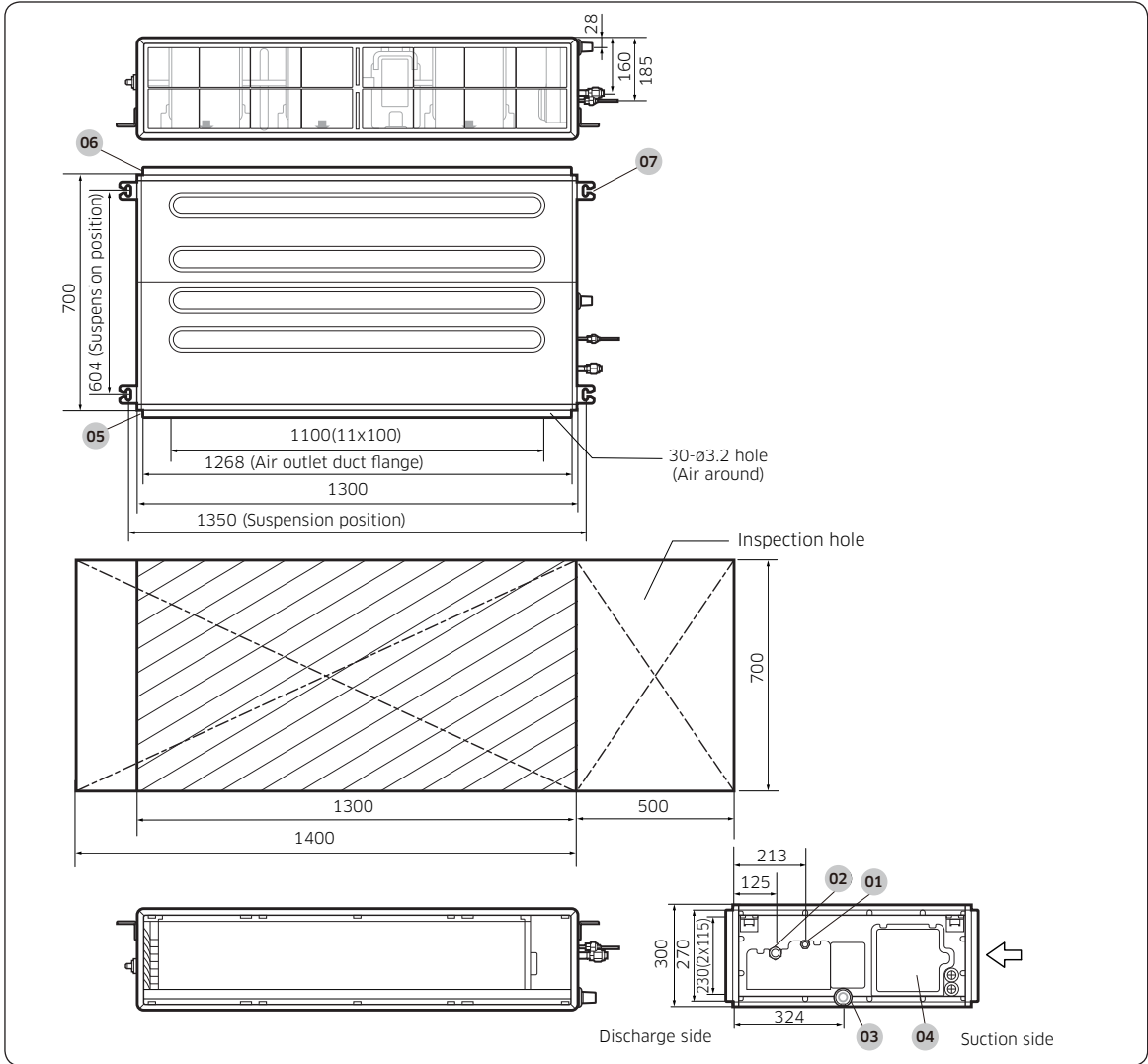

No.	Name	Description
01	Liquid pipe connection	ø9.52(3/8")
02	Gas pipe connection	ø15.88(5/8")
03	Drain pipe connection	OD25 ID20(without drain pump)
04	Power supply connection	
05	Air discharge flange	
06	Air filter	
07	Hook	M8~M10

Installation Procedure

Step 3 Optional: Insulating the body of the indoor unit

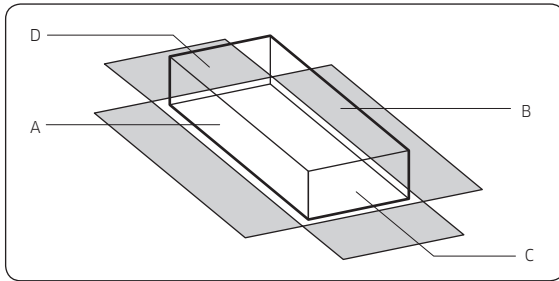

Thickness: more than 10mm

Indoor Unit	AC026RNLDKG AC035RNLDKG	AC052RNLDKG AC071RNLDKG	AC035RNMDKG AC052RNMDKG AC071RNMDKG
		700 X 600 X 199	1100 X 450 X 200
A	700 X 199	1100 X 200	850 X 250
B	700 X 199	1100 X 200	850 X 250
C	600 X 199	450 X 200	700 X 250
D	600 X 199	450 X 200	700 X 250
Front/ Back	Insulate the front and back side in proper size at the same time when insulating the suction duct and discharge duct.		

(Unit: mm)

Indoor Unit	AC100RNMDKG	AC120RNMDKG AC140RNMDKG
		1200 X 700 X 250
A	1200 X 250	1300 X 300
B	1200 X 250	1300 X 300
C	700 X 250	700 X 300
D	700 X 250	700 X 300
Front/ Back	Insulate the front and back side in proper size at the same time when insulating the suction duct and discharge duct.	

(Unit: mm)

NOTE

- Insulate the end of the pipe and some curved area by using separate insulator.
- Insulate the discharge and suction part at the same time when you insulate connection duct.

Step 4 Installing the indoor unit

When deciding on the location of the air conditioner with the owner, the following restrictions must be taken into account

- 1 Place the pattern sheet on the ceiling at the spot where you want to install the indoor unit.

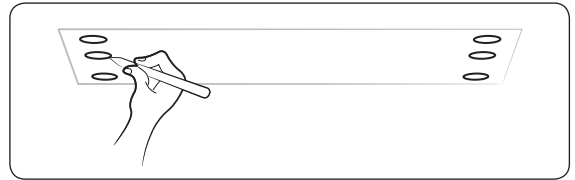

NOTE

- Since the diagram is made of paper, it may shrink or stretch slightly due to temperature or humidity. For this reason, before drilling the holes maintain the correct dimensions between the markings.
- 2 Insert bolt anchors. Use existing ceiling supports or construct a suitable support as shown in figure.

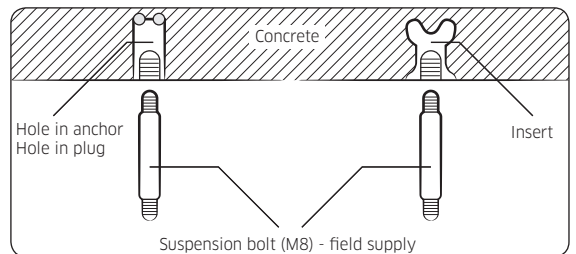

3 Install the suspension bolts depending on the ceiling type.

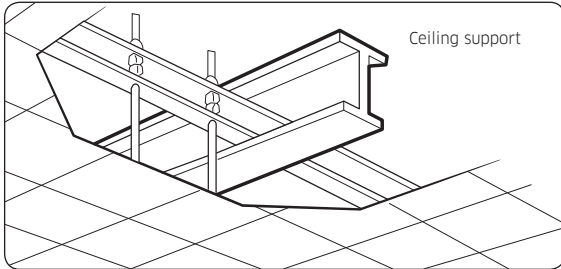

CAUTION

- Ensure that the ceiling is strong enough to support the weight of the indoor unit. Before hanging the unit, test the strength of each attached suspension bolt.
- If the length of suspension bolt is more than 1.5m, it is required to prevent vibration.
- If this is not possible, create an opening on the false ceiling in order to be able to use it to perform the required operations on the indoor unit.

4 Screw eight nuts to the suspension bolts making space for hanging the indoor unit.

NOTE

- You must install all the suspension rods.
- 5 Hang the indoor unit to the suspension bolts between two nuts.

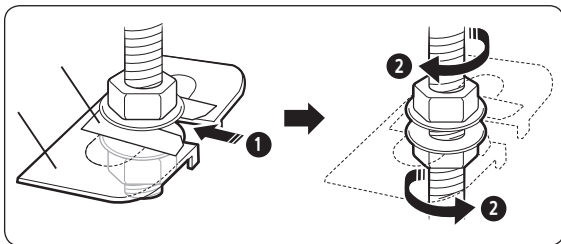

CAUTION

- Piping must be laid and connected inside the ceiling when suspending the unit. If the ceiling is already constructed, lay the piping into position for connection to the unit before placing the unit inside the ceiling.

6 Screw the nuts to suspend the unit.

7 Adjust level of the unit by using measurement plate for all 4 sides.

CAUTION

- For proper drainage of condensate, give a 3mm slant to the left or right side of the unit which will be connected with the drain hose, as shown in the figure. Make a tilt when you wish to install the drain pump, too.

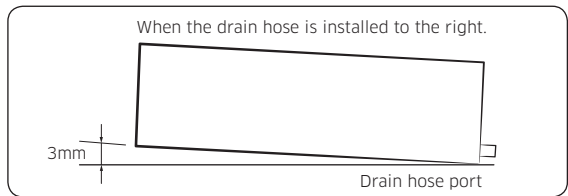

- When installing the indoor unit, make sure it is not tilted toward front or back side.

CAUTION

- Noise will increase 3~6 dB(A) when the air flow enters from the bottom side (Only for Slim Duct Type product).

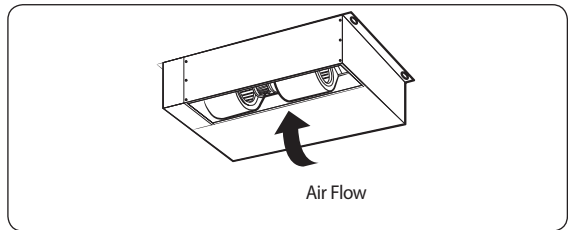

Installation Procedure

Step 5 Purging inert gas from the indoor unit

From factory the unit is supplied and set with a pre-charge of nitrogen gas. (inert gas) Therefore, all inert gas must be purged before connecting the assembly piping.

Unscrew the pinch pipe at the end of each refrigerant pipe.
Result : All inert gas escapes from the indoor unit.

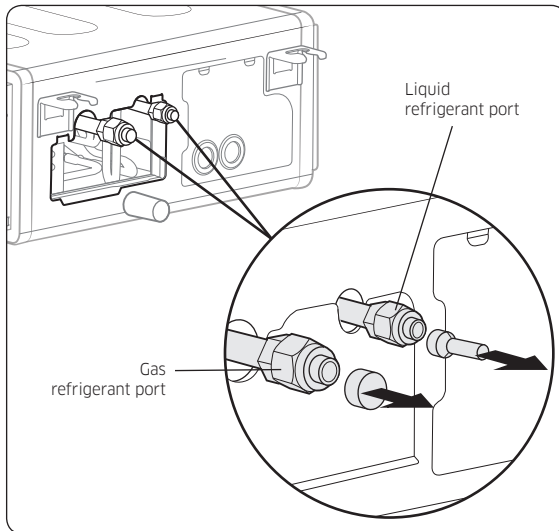

NOTE

- The designs and shape are subject to change according to the model.
- To prevent dirt or foreign objects from getting into the pipes during installation, do NOT remove the pinch pipe completely until you are ready to connect the piping.

CAUTION

- Connect the indoor and outdoor units using pipes with flared connections(not supplied). For the lines, use insulated, unwelded, degreased and deoxidized copper pipe (Cu DHP type to ISO 1337 or UNI EN 12735-1), suitable for operating pressures of at least 4200kPa and for a burst pressure of at least 20700kPa. Copper pipe for hydro-sanitary applications is completely unsuitable.
- For sizing and limits (height difference, line length, max. bends, refrigerant charge, etc.) see the outdoor unit installation manual.
- All refrigerant connection must be accessible, in order to permit either unit maintenance or removing it completely.

Step 6 Cutting and flaring the pipes

- 1 Make sure that you have the required tools available. (pipe cutter, reamer, flaring tool and pipe holder)
- 2 If you wish to shorten the pipes, cut it with a pipe cutter, taking care to ensure that the cut edge remains at a 90° angle with the side of the pipe. Refer to the illustrations below for examples of edges cut correctly and incorrectly.

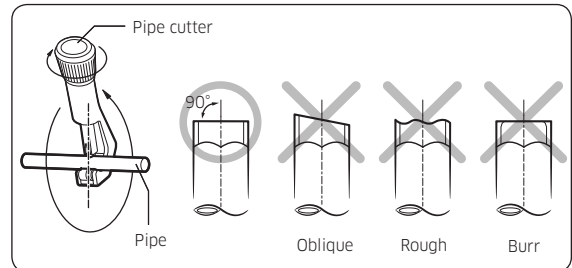

- 3 To prevent any gas from leaking out, remove all burrs at the cut edge of the pipe, using a reamer.
- 4 Slide a flare nut on to the pipe and modify the flare.

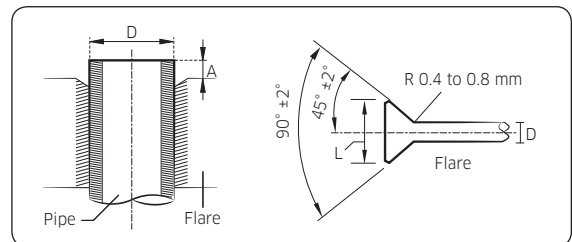

Outer Diameter (D)	Depth (A)	Flare dimension (L)
Ø6.35 mm	1.3 mm	8.7~9.1 mm
Ø9.52 mm	1.8 mm	12.8~13.2 mm
Ø12.70 mm	2.0 mm	16.2~16.6 mm
Ø15.88 mm	2.2 mm	19.3~19.7 mm
Ø19.05 mm	2.2 mm	23.6~24.0 mm

- 5 Check that the flaring is correct, referring to the illustrations below for examples of incorrect flaring.

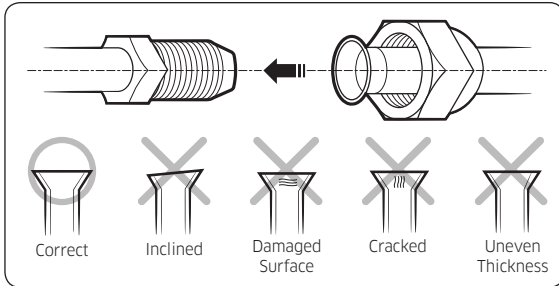

⚠ CAUTION

- If the pipes require brazing ensure that OFN (Oxygen Free Nitrogen) is flowing through the system.
- Nitrogen blowing pressure range is 0.02 ~ 0.05MPa.

Step 7 Connecting the assembly pipes to the refrigerant pipes

There are two refrigerant pipes of different diameters :

- A smaller one for the liquid refrigerant
- A larger one for the gas refrigerant
- The inside of copper pipe must be clean & has no dust

- 1 Remove the pinch pipe on the pipes and connect the assembly pipes to each pipe, tightening the nuts, first manually and then with a torque wrench, a spanner applying the following torque.

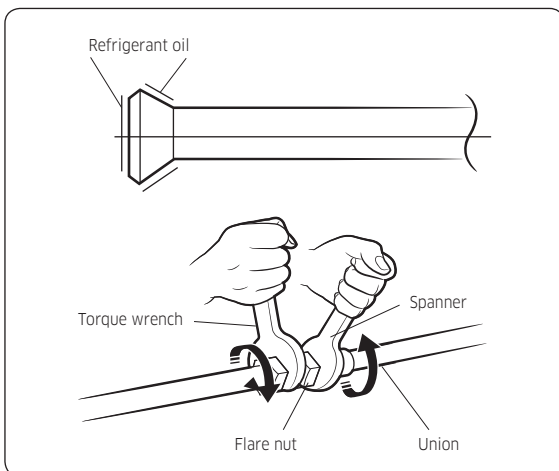

Outer diameter (D)	Torque (N•m)
Ø6.35 mm	14 ~ 18
Ø9.52 mm	34 ~ 42
Ø12.70 mm	49 ~ 61
Ø15.88 mm	68 ~ 82
Ø19.05 mm	100 ~ 120

NOTE

- If the pipes must be shortened refer to page 14, **Step 6 Cutting and flaring the pipes**
 - Tighten the nuts to the specified torques. If overtightened, the nuts could be broken so refrigerant may leak.
- 2 Be sure to use insulator which is thick enough to cover the refrigerant tube to protect the condensate water on the outside of pipe falling onto the floor and the efficiency of the unit will be better.
 - 3 Cut off any excess foam insulation.
 - 4 Be sure that there must be no crack or wave on the bended area.
 - 5 It would be necessary to double the insulation thickness(10mm or more) to prevent condensation even on the insulator when if the installed area is warm and humid.
 - 6 Do not use joints or extensions for the pipes that connect the indoor and outdoor unit. The only permitted connections are those for which the units are designed.

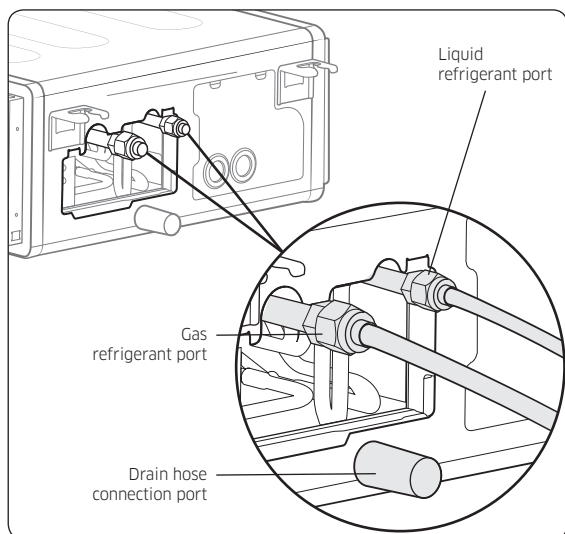

NOTE

- The designs and shape are subject to change according to the model.

Installation Procedure

Step 8 Performing the gas leak test

To identify potential gas leaks on the indoor unit, inspect the connection area of each refrigerant pipe using a leak detector for R-32.

Before recreating the vacuum and recirculating the refrigerant gas, pressurize the whole system with nitrogen (using a cylinder with a pressure reducer) at a pressure above 4 MPa in order to immediately detect leaks on the refrigerant fittings.

Made vacuum for 15 minutes and pressurizing system with nitrogen.

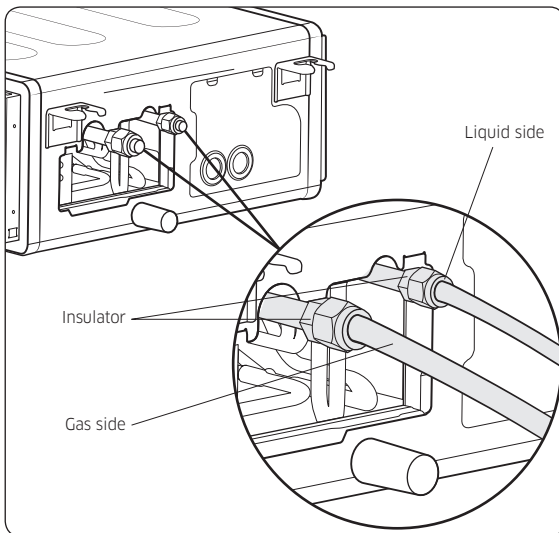

- 2 Wind insulating tape around the pipes and drain hose avoiding compressing the insulation too much.

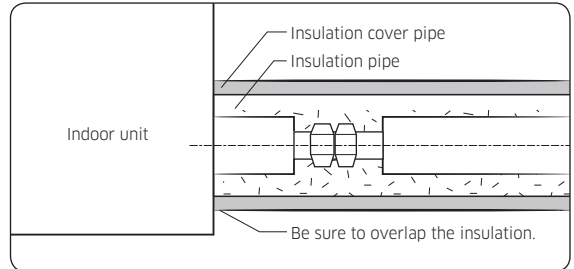

⚠ CAUTION

- Be sure to wrap insulation tightly without any gaps.
- 3 Finish wrapping insulating tape around the rest of the pipes leading to the outdoor unit.
 - 4 The pipes and electrical cables connecting the indoor unit with the outdoor unit must be fixed to the wall with suitable ducts.

⚠ CAUTION

- Make sure that all refrigerant connection must be accessible for easy maintenance and detachment.
- Install the insulation not to get wider and use the adhesives on the connection part of it to prevent moisture from entering.
- Wind the refrigerant pipe with insulation tape if it is exposed to outside sunlight.
- Install the refrigerant pipe respecting that the insulation does not get thinner on the bent part or hanger of pipe.
- Add the additional insulation if the insulation plate gets thinner.

Step 9 Insulating the refrigerant pipes

Once you have checked that there are no leaks in the system, you can insulate the piping and hose.

- 1 To avoid condensation problems, place Acrylonitrile Butadien Rubber separately around each refrigerant pipe.

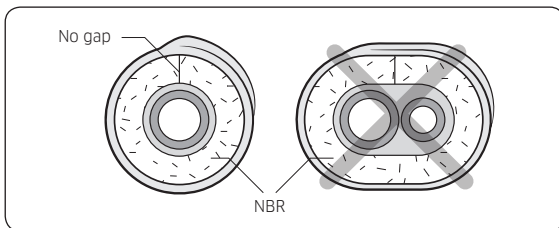

📄 NOTE

- Always make the seam of pipes face upwards.

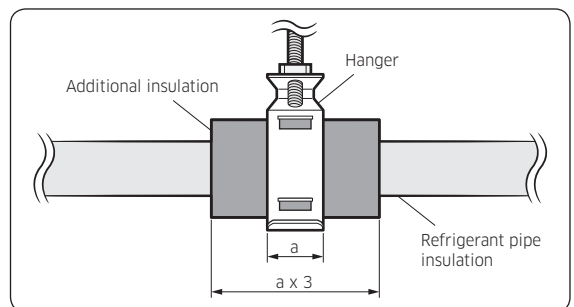

- 5 Select the insulation of the refrigerant pipe.
 - Insulate the gas side and liquid side pipe, noting the insulation thickness that must differ according to the pipe size.
 - Standard: Less than an indoor temperature of 30°C, with humidity at 85%. If installing in a high humidity environment, use one grade thicker insulator by referring to the table below. If installing in an unfavourable environment, use thicker one.
 - The heat-resistance temperature of the insulator must be more than 120°C.

Pipe	Pipe size	Insulation type (heating/cooling)		Remarks
		Standard (Less than 30°C, 85%)	High humidity (Over 30°C, 85%)	
		EPDM, NBR		
Liquid pipe	Ø6.35 to Ø9.52	9t	9t	The internal temperature is higher than 120°C.
	Ø12.7 to Ø19.05	13t	13t	
Gas pipe	Ø6.35	13t	19t	
	Ø9.52	19t	25t	
	Ø12.70			
	Ø15.88			
Ø19.05				

- When installing insulation in the places and conditions below, use the same insulation that is used for high humidity conditions.

<Geological condition>
High humidity locations such as shorelines, hot springs, lake or riversides, and ridges (when part of the building is covered by earth and sand)
<Operation purpose condition>
Restaurant ceiling, sauna, swimming pool etc.
<Building construction condition>
Ceilings frequently exposed to moisture and cooling are not covered. For example, pipes installed at a corridor of a dormitory and studio or near an exit that opens and closes frequently.
Places (where the pipes are installed) that are highly humid due to a lack of ventilation.

Step 10 Installing the drain hose and drain pipe

- 1 Push the supplied drain hose as far as possible over the drain socket.
- 2 Tighten the metal clamp as shown in the picture.

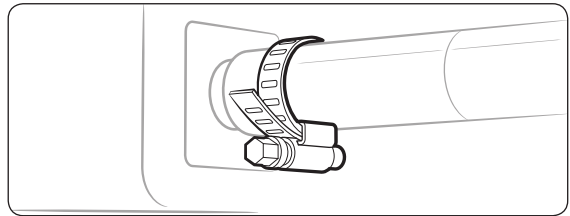

- 3 Wrap the supplied large sealing pad over the metal clamp and drain hose to insulate and fix it with clamps.
- 4 Insulate the complete drain piping inside the building (field supply).
If the drain hose cannot be sufficiently set on a slope, fit the hose with drain raising piping (field supply).
- 5 Push the drain hose up to insulation when connecting the drain hose to drain socket.

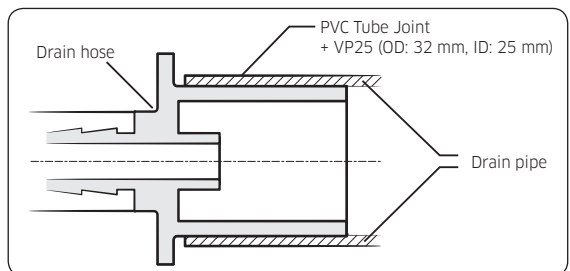
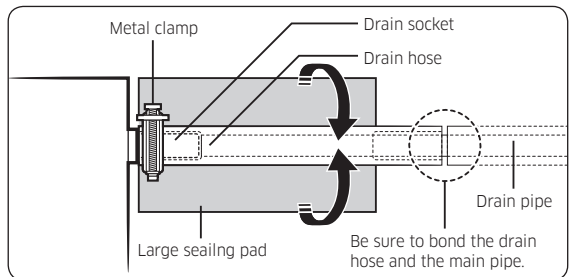

Installation Procedure

Without the drain pump

- 1 Install horizontal drainpipe with a slope of 1/100 or more and fix it by hanger space of 1.0~1.5m.
- 2 Install U-trap at the end of the drainpipe to prevent a nasty smell to reach the indoor unit.
- 3 Do not install the drainpipe to upward position. It may cause water flow back to the unit.

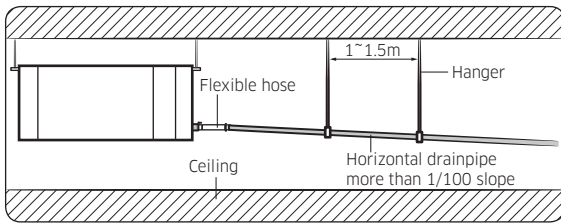

With the drain pump

- 1 The drain pipe should be installed within 300mm to 550mm from the flexible hose and then lift down 20mm or more.
- 2 Install horizontal drainpipe with a slope of 1/100 or more and fix it by hanger space of 1.0~1.5m.
- 3 Install the air vent in the horizontal drainpipe to prevent water flow back to the indoor unit.

NOTE

- You may not need to install it if there were proper slope in the horizontal drainpipe.
- 4 The flexible hose should not be installed upward position, it may cause water flow back to the indoor unit.

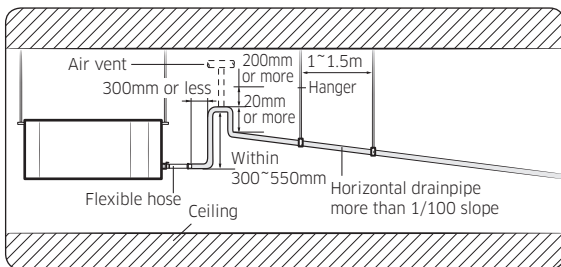

Step 11 Performing the drainage test

Prepare a little water about 2 liter.

- 1 Pour water into the base pan in the indoor unit as shown in figure.
- 2 Confirm that the water flows out through the drain hose.

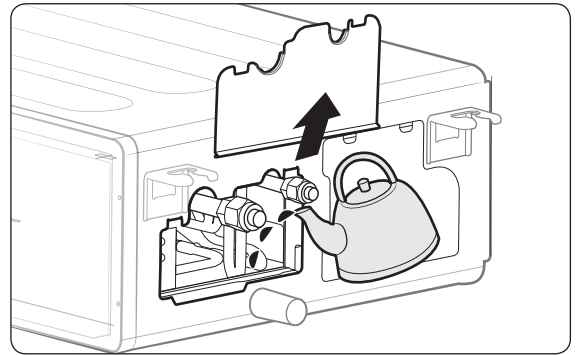



Step 12 Optional: Installing DPM

- When installing DPM, you should set "DPM setting" to the outdoor unit.
- If DPM model is not set, communication error may occur.
- While the outdoor unit is tracking the indoor unit for one minute after the power supply is turned on. The operation may stop if the remote control reception signal of the installed indoor unit is different.
- When DPM is installed, Automatic Air-Volume function cannot be performed simultaneously for all indoor units. Automatic Air-Volume function must be performed for each indoor unit with the wired remote control attached.
- To enable Level control with the centralized controller, refer to page 28

Step 13 Optional: Installing external controller

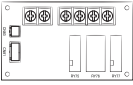
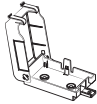
Accessories (External controller : MIM-B14)

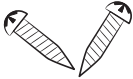
External Controller	PCB Case
	
Haness Wire	Haness Wire
	
Screw	
	

- 1 Fix the case at with bolts on the side of the control box in the indoor unit.(See the picture).
- 2 Attach the external controller PCB to the case in the control box of the indoor unit.
- 3 Connect the harness wires.

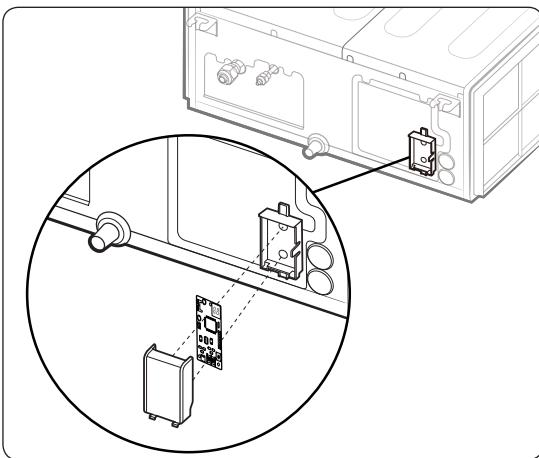

Accessories (SPI module : MSD-EAN1)

Refer to the SPI module(MSD-EAN1) installation manual for the more information.

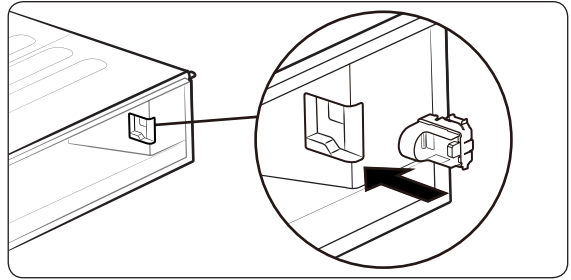

Step 14 Connecting the power and communication cables

⚠ CAUTION

- Always remember to connect the refrigerant pipes before performing the electric connections. When disconnecting the system, always disconnect the electric cables before disconnecting the refrigerant pipes.

⚠ CAUTION

- Always remember to connect the air conditioner to the grounding system before performing the electric connections. Use a crimp ring terminal at the end of each wire.

The indoor unit is powered through the outdoor unit by means of a H07 RN-F connection cable (or a more power model), with insulation in synthetic rubber and a jacket in polychloroprene (neoprene), in accordance with the requirements specified in the standard EN 60335-2-40.

- 1 Remove the screw on the electrical component box and remove the cover plate.
- 2 Route the connection cord through the side of the indoor unit and connect the cable to the terminals refer to the figure below.
- 3 Route the other end of the cable to the outdoor unit through the ceiling & the hole on the wall.
- 4 Reassemble the electrical component box cover, carefully tightening the screw.

Installation Procedure

1 phase (**026/035/052/071/100/120/140**)

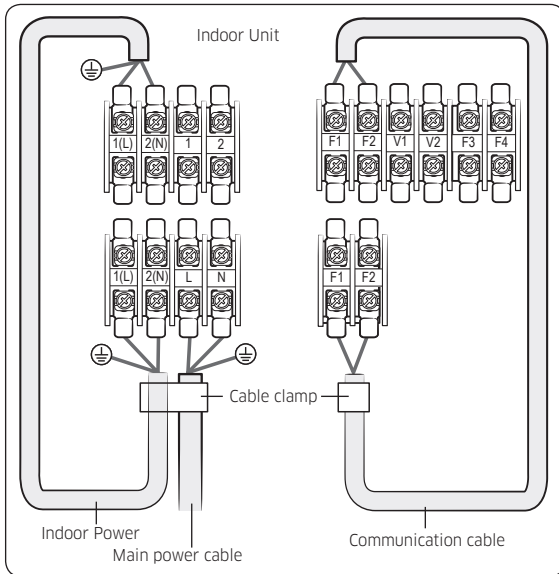

Indoor power supply		
Power supply	Max/Min(V)	Indoor power cable
220 to 240V, 50 Hz	±10%	0.75 to 1.5 mm ² , 3 wires
Communication cable		
0.75 mm ² , 2 wires		

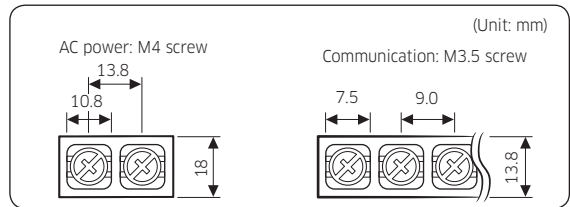

Tightening torque (kgf • cm)	
M3.5	8.0 to 12.0
M4	12.0 to 18.0

- 1 N•m = 10 kgf•cm
- Power supply cords of parts of appliances for outdoor use shall not be lighter than polychloroprene sheathed flexible cord. (Code designation IEC:60245 IEC 57 / CENELEC: H05RN-F or IEC:60245 IEC 66 / CENELEC: H07RN-F)
- Since it has the external power supply, refer to the outdoor unit installation manual for MAIN POWER.

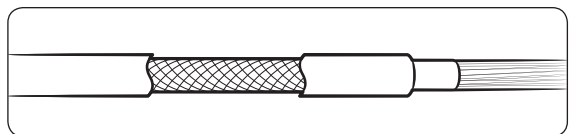

⚠ CAUTION



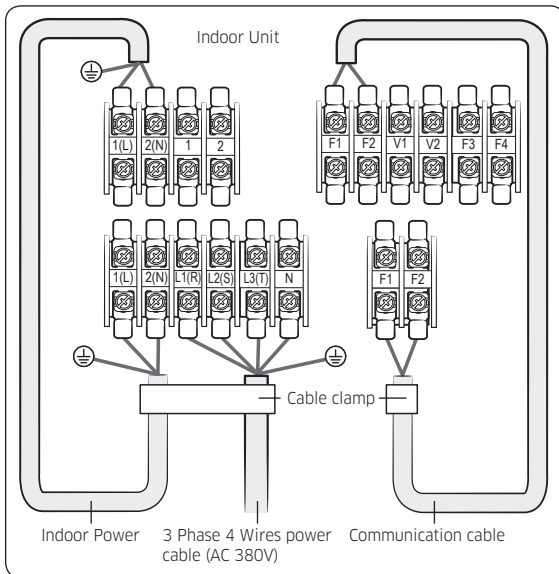

- When installing the indoor unit in a computer room or a server room, use the double shielded communication cable (tape aluminum / polyester braid + copper) of FROHH2R type.

3 phase (**100/120/140**)



Step 15 Optional: Extending the power cable

1 Prepare the following tools.

Tools	Spec	Shape
Crimping pliers	MH-14	
Connection sleeve (mm)	20xØ6.5 (HxOD)	
Insulation tape	Width 19 mm	
Contraction tube (mm)	70xØ8.0 (LxOD)	

2 As shown in the figure, peel off the shields from the rubber and wire of the power cable.

- Peel off 20 mm of cable shields from the pre-installed tube.

CAUTION

- For information about the power cable specifications for indoor and outdoor units, refer to the installation manual.
- After peeling off cable wires from the pre-installed tube, insert a contraction tube.

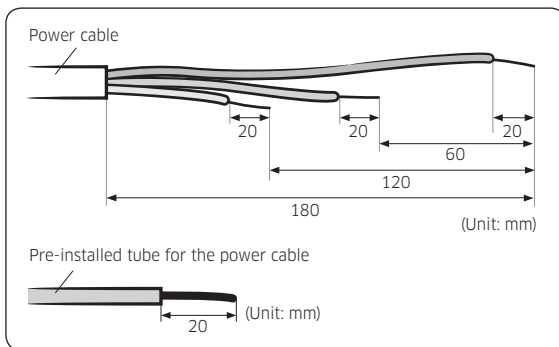

3 Insert both sides of core wire of the power cable into the connection sleeve.

- **Method 1:** Push the core wire into the sleeve from both sides.
- **Method 2:** Twist the wire cores together and push it into the sleeve.

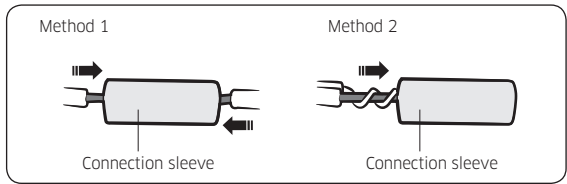

4 Using a crimping tool, compress the two points and flip it over and compress another two points in the same location.

- The compression dimension should be 8.0.

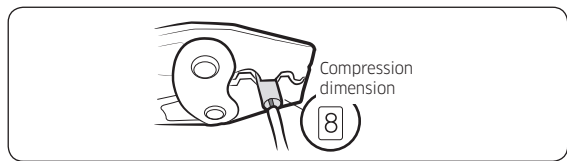

- After compressing it, pull both sides of the wire to make sure it is firmly pressed.

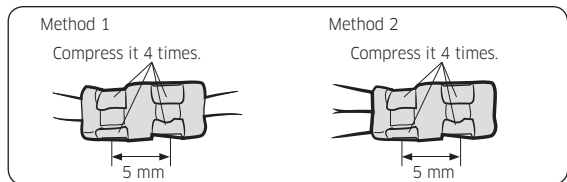

5 Wrap it with the insulation tape twice or more and position your contraction tube in the middle of the insulation tape. Three or more layers of insulation are required.

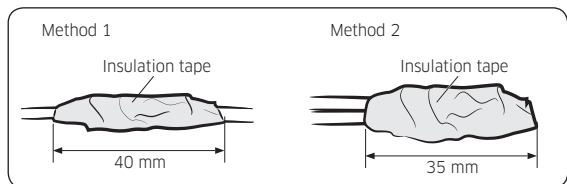

6 Apply heat to the contraction tube to contract it.

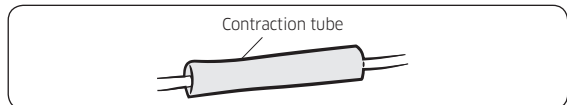

7 After tube contraction work is completed, wrap it with the insulation tape to finish.

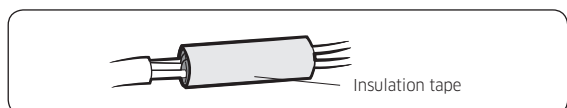

Installation Procedure

⚠ CAUTION

- Make sure that the connection parts are not exposed to outside.
- Be sure to use insulation tape and a contraction tube made of approved reinforced insulating materials that have the same level of withstand voltage with the power cable. (Comply with the local regulations on extensions.)

⚠ WARNING

- In case of extending the electric wire, please DO NOT use a round-shaped Pressing socket.
 - Incomplete wire connections can cause electric shock or a fire.

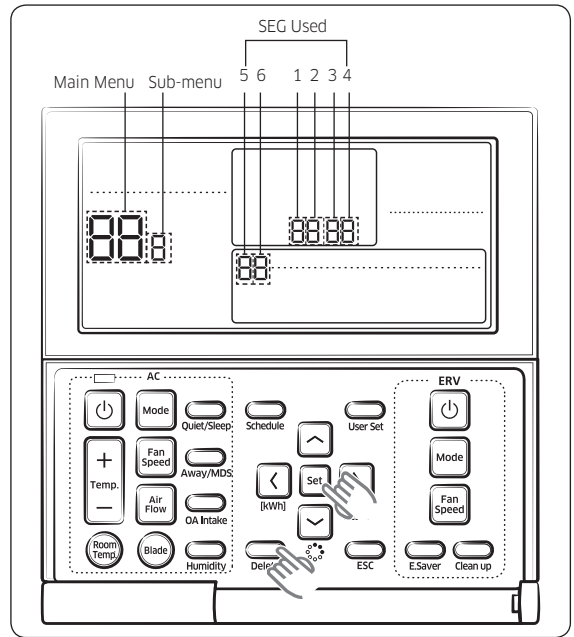
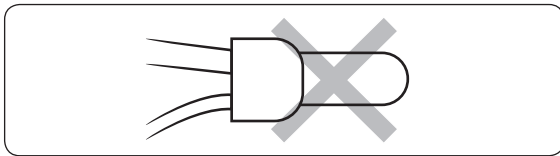

Step 16 Setting additional functions of wired remote control

Automatic Air-Volume

When DPM is installed, Automatic Air-Volume function cannot be performed simultaneously for all indoor units. Automatic Air-Volume function must be performed for each indoor unit with the wired remote control attached. With its BLDC motor, you can use smart adjust the indoor unit fan speed depending on the installation condition. If the external static pressure is high so that the duct becomes longer or if the external static pressure is low so that the duct becomes shorter, Using the Automatic Air-Volume function, the volume of exhaust air has been adjusted to the rated volume flow rate automatically.

Performing the Automatic Air-Volume function.

- Check the air conditioning unit stop.
- Press the Power button to stop the air conditioner
- Go to Service setting mode with remote controller.
 - 1 Press the **Set** and **Delete** buttons at the same time for more than 3 seconds and then a Main menu will be displayed.
 - 2 Press the **Up/Down** button to select **8** and then press **Right** button to enter a Sub-menu setting screen.
 - 3 Press the **Up/Down** button to select **2** and then press **Right** button to enter a automatic air-volume setting screen.
 - 4 Press the **Up/Down** button to select 1 to enable automatic air-volume operation.
 - 5 Select mode No. 8.2 , and set to "1".
 - 6 Press the **Set** button, then the air conditioning unit will start the fan operation for Automatic Air-Volume adjustment.
 - Do not adjust the dampers during fan operation for Automatic Air-Volume adjustment.
 - 7 Press **ESC** button to escape setting mode. (During the automatic air-volume adjustment, [Main Menu] will be displayed repetitively)
 - 8 After 1 to 8 minutes, the air conditioning unit stops operating automatically when Automatic Air-Volume adjustment has been carried out (fan operation icon will be off.)

- 9 When the air conditioning unit has stopped, check the Mode No. 8.1 is "1" for completion of Automatic Air-Volume.

If the Mode No. 8.1 is "0", Automatic Air-Volume adjustment is fail. Then adjust the fan speed by referring the E. S. P(External Static Pressure) setting table.

Main menu	Sub menu	Functions	SEG used	Default	Range
8	1	Automatic Air-Volume State Return	1	0	0 - OFF (Fail or Disable) 1 - Completion. 2 - Running Automatic Air-Volume.
	2	Automatic Air-Volume Operation	1	0	0 - Disable 1 - Enable

NOTE

- If the coil is not dry, run the unit for 2 hours with fan only to dry the coil.
- The air filter is properly attached into the air passage on the air suction side of the air conditioning unit.
- Adjust the dampers so that each air inlet and outlet exhusts the designed airflow rate.
- If using booster fans(an outdoor air processing unit or ERV via duct), do not use Automatic Air-Volume function.
- If the duct configurations have been changed, automatic air-volume function perform again.

External Static Pressure (ESP) setting for phase control motor

With its phase control motor, you can adjust the indoor unit fan speed depending on the installation condition. If the external static pressure is high so that the duct becomes longer or if the external static pressure is low so that the duct becomes shorter, adjust the fan speed by referring the following table.

Model	AC026RNLDKG	AC035RNLDKG
Static Pressure	Option Code for Indoor Unit	
0≤ SP ≤2.5	01C17C-1C1914-271A21-370000	01C17C-1C3936-272328-370000
2.5< SP ≤4	01C17C-1C1969-271A21-370000	01C17C-1C39AD-272328-370000

Model	AC052RNLDKG	AC071RNLDKG
Static Pressure	Option Code for Indoor Unit	
0≤ SP ≤3	01C17C-1C1924-27343C-370000	01C17C-1C59D0-274750-370005
3< SP ≤4	01C17C-1C1968-27343C-370000	01C17C-1C5D21-274750-370005

Model	AC035RNMDKG
Static Pressure	Option Code for Indoor Unit
0≤ SP ≤2.5	01B17C-1C5080-272328-372008
2.5< SP ≤5	01B17C-1C5407-272328-372008
5< SP ≤7.5	01B17C-1C548C-272328-372008
7.5< SP ≤10	01B17C-1C55D3-272328-372008
10< SP ≤12.5	01B17C-1C5926-272328-372008
12.5< SP ≤15	01B17C-1C5998-272328-372008



Model	AC052RNMDKG	AC071RNMDKG
Static Pressure	Option Code for Indoor Unit	
0≤ SP ≤3	01B17C-1C50F1-27343C-374000	01B17C-1C5436-274750-376000
3< SP ≤6	01B17C-1C5488-27343C-374000	01B17C-1C54AB-274750-376000
6< SP ≤9	01B17C-1C54ED-27343C-374000	01B17C-1C581E-274750-376000
9< SP ≤12	01B17C-1C5941-27343C-374000	01B17C-1C5972-274750-376000
12< SP ≤15	01B17C-1C59B3-27343C-374000	01B17C-1C59C8-274750-376000

Model	AC100RNMDKG
Static Pressure	Option Code for Indoor Unit
0≤SP≤4	01B17C-1C549F-276470-375020
4<SP≤8	01B17C-1C5917-276470-375020
8<SP≤12	01B17C-1C599C-276470-375020
12<SP≤15	01B17C-1C5AE1-276470-375020

Model	AC120RNMDKG	AC140RNMDKG
Static Pressure	Option Code for Indoor Unit	
0≤SP≤5.2	01B17C-1C5424-277882-374040	01B17C-1C5424-278CA0-374045
5.2<SP≤8	01B17C-1C5489-277882-374040	01B17C-1C5489-278CA0-374045
8<SP≤12	01B17C-1C54FE-277882-374040	01B17C-1C54FE-278CA0-374045
12<SP≤15	01B17C-1C5940-277882-374040	01B17C-1C5940-278CA0-374045

Installation Procedure

NOTE

-  represents E. S. P(External Static Pressure) range of factory setting.
 You don't have to adjust the fan speed separately if the external static pressure of the installation place is in . When it is out of , input the appropriate option code.
- If you input the inappropriate option code, error may occur or the air conditioner is out of order. The option code must be inputted correctly by the installation specialist or service agent.

EASY Tuning

If the more cooling and heating airflow rate which set up when installing is wanted, or if the more Silent operation which sets up when installing is wanted, air conditioner is tuned for comfort. Indoor unit airflow rate for high, mid, low mode increases or decreases for +2 ~ -2 Steps with wired remotecontrol.

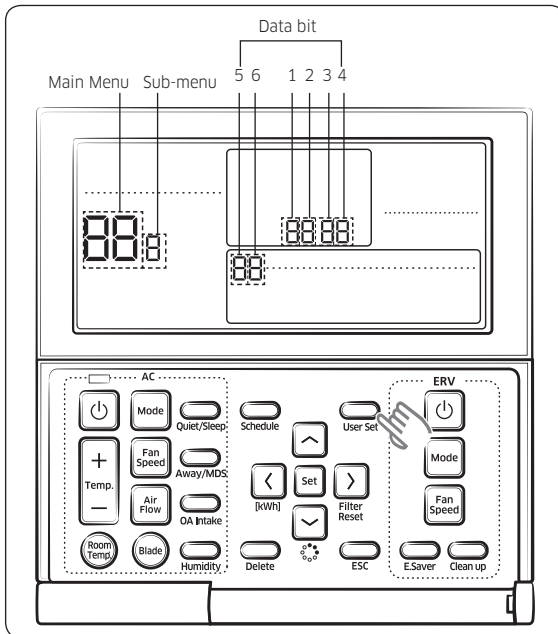

- Press the User Set button. (Main Menu) will be displayed, and you can press the [^]/[v] buttons to select No. 8, which will set the Easy Tuning.

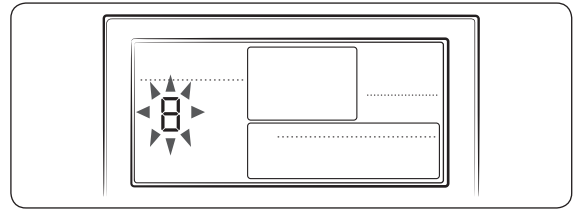

- Press the [>] button to select airflow step. Press the [^]/[v] buttons to select airflow step(-2,-1,0,1,2) tuning (During the Easy Tuning setting, AC Fan Speed icon will be displayed)

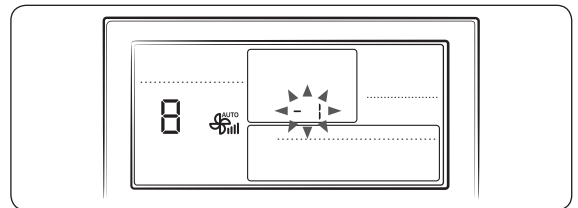

- Press the [Set] button to complete the Easy Tuning. (When the Easy Tuning setting complete, AC Fan Speed icon will be off)

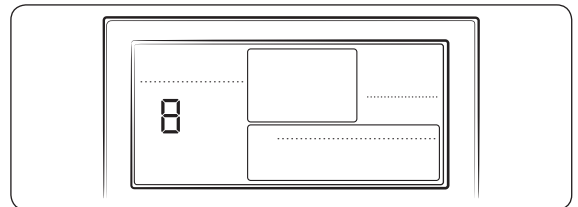

- Press the [ESC] button to exit to normal mode.

Main menu	Sub menu	Functions	SEG used	Default	Range
8	-	Easy Tuning	1,2	0	-2 : -2 Step -1 : -1 Step 0 : No Use 1 : +1 Step 2 : +2 Step

NOTE

- Press the [ESC] button anytime during setup to exit without setting.
- According to airflow changed from the Easy Tuning, Air conditioning performance reducing is possible.

Step 17 Setting the indoor unit option code

In order to set the indoor unit option code use the wired remote controller and follow the directions below.

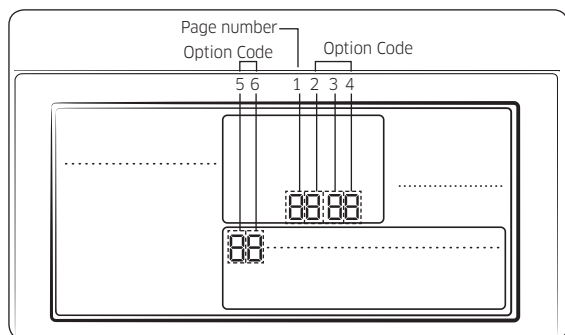
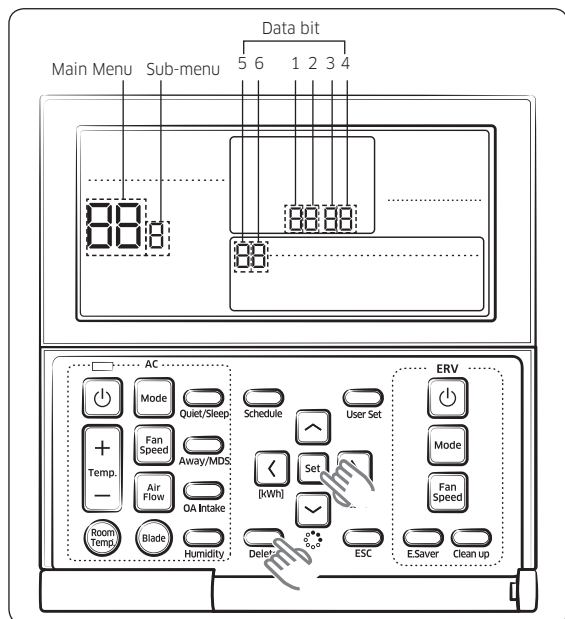

SEG1	SEG2	SEG3	SEG4	SEG5	SEG6
0	*	*	*	*	*

Page number

SEG7	SEG8	SEG9	SEG10	SEG11	SEG12
1	*	*	*	*	*

Page number

SEG13	SEG14	SEG15	SEG16	SEG17	SEG18
2	*	*	*	*	*

Page number

SEG19	SEG20	SEG21	SEG22	SEG23	SEG24
3	*	*	*	*	*

Page number

- 1 Press the and buttons at the same time for more than 3 seconds and then a Main menu will be displayed.
- 2 Press the button to select **4** and then press button to enter a Sub-menu setting screen.
- 3 Press the button to select **2** and then press button to enter a Indoor unit option code setting screen.

NOTE

- The first digit represents the page number and the remaining five digits are option codes.
- The option code which is currently setting will flicker.

- 4 Press the button to set the option code in order. Press button to go to the next page.

- 5 Press the button to save and complete the option setting.

- 6 Press the button to exit to normal mode.

NOTE

- Press the button anytime during setup to exit without setting.

CAUTION

- Option code will not be applied if you don't press the .
- Setting indoor unit option code is only possible in Master wired remote controller. You can only check the indoor unit option code in Slave wired remote controller.
- Setting indoor unit option code is possible when one indoor unit is connected. If more than 2 indoor units are connected, you can only check the Master indoor unit option code.

Installation Procedure

Step 18 Setting indoor unit addresses and installation options

Set the indoor unit address and installation option with remote controller option. Set the each option separately since you cannot set the ADDRESS setting and indoor unit installation setting option at the same time. You need to set twice when setting indoor unit address and installation option.

Setting an indoor unit address

- 1 Press the **Set** and **Delete** buttons at the same time for more than 3 seconds and then a Main menu will be displayed.
- 2 Press the **Up** / **Down** button to select **4** and then press **Right** button to enter a Sub-menu setting screen.
- 3 Press the **Up** / **Down** button to select **!** and then press **Right** button to enter a Indoor Address setting screen.

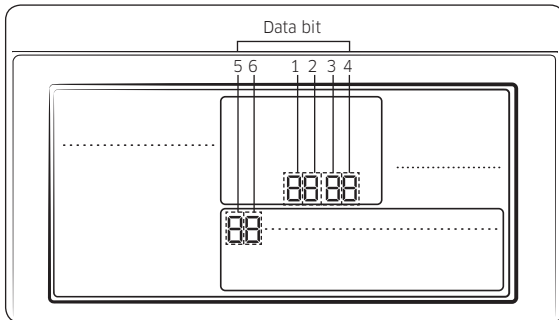

NOTE

- The Main/RMC Address which is currently setting will flicker.
 - Data bit 1 and 2 present Indoor unit main address checking
 - Data bit 3 and 4 present Indoor unit main address setting(outdoor unit reset is needed to set).
 - Data bit 5 and 6 present Indoor unit RMC address setting/checking.
- 4 Press the **Up** / **Down** button to set the Indoor unit Main/RMC Address.
 - 5 Press the **Set** button to save and complete the option setting.
 - 6 Press the **ESC** button to exit to normal mode.

NOTE

- Press the **ESC** button anytime during setup to exit without setting.
- Address will not be applied if you don't press **Set** button.
- Setting Main/RMC Address of an Indoor unit is available only with a master wired remote controller.

Setting an indoor unit installation option

In order to check and set the indoor unit installation option code use the wired remote controller and follow the directions below.

- 1 Press the **Set** and **Delete** buttons at the same time for more than 3 seconds and then a Main menu will be displayed.
- 2 Press the **Up** / **Down** button to select **4** and then press **Right** button to enter a Sub-menu setting screen.
- 3 Press the **Up** / **Down** button to select **3** and then press **Right** button to enter a Indoor unit installation option code setting screen.

NOTE

- The first digit represents the page number and the remaining five digits are installation option.
 - The total option codes are 24 digits. You can set six digits at a time and it is distinguished by page number (0, 1, 2, 3).
- 4 Press the **Up** / **Down** button to set the installation option code in order. Press **Right** button to go to the next page.

SEG1	SEG2	SEG3	SEG4	SEG5	SEG6
0	2	RESERVED	Exterior temperature sensor	Central control	RESERVED
SEG7	SEG8	SEG9	SEG10	SEG11	SEG12
1	Drain pump	Use of Hot Coil	Use of Heater	Controller variables for auxiliary heater	RESERVED
SEG13	SEG14	SEG15	SEG16	SEG17	SEG18
2	External control	External control output	S-Plasma ion	Buzzer	Number of hours using filter
SEG19	SEG20	SEG21	SEG22	SEG23	-
3	Individual control of a remote controller	Heating setting compensation	RESERVED	Away Set OFF Timer	-

Option No. : 02XXXX-1XXXXX-2XXXXX-3XXXXX

Option	SEG1		SEG2		SEG3			SEG4		
Explanation	PAGE		MODE		RESERVED			Use of external temperature sensor		
Indication and Details	Indication	Details	Indication	Details				Indication	Details	
	0		2					0	Disuse	1
Option	SEG5		SEG6		SEG7		SEG8			
Explanation	Use of central control		RESERVED		PAGE		Use of drain pump			
Indication and Details	Indication	Details			Indication	Details	Indication	Details		
	0	Disuse			1		0	Disuse		
	1	Use	1	Use			2	Use + 3minute delay		
Option	SEG9		SEG10		SEG11			SEG12		
Explanation	Use of Hot Coil		Use of heater		Controller variables for auxiliary heater			RESERVED		
Indication and Details	Indication	Details	Indication	Details	Indication	Details				
	0	Disuse	0	Disuse		Set temperature for auxiliary heat on	Time delay for auxiliary heat on			
						0	No temperature offset			No delay
						1	No temperature offset			10 minutes
	1	Use	1	Use	2	No temperature offset	20 minutes			
					3	1.5°C	No delay			
					4	1.5°C	10 minutes			
					5	1.5°C	20 minutes			
					6	3°C	No delay			
					7	3°C	10 minutes			
	-	-	2	Use (Heater time delay)	8	3°C	20 minutes			
					9	4.5°C	No delay			
					A	4.5°C	10 minutes			
B					4.5°C	20 minutes				
C					6°C	No delay				
D	6°C	10 minutes								
E	6°C	20 minutes								

Installation Procedure

Option	SEG13		SEG14		SEG15		SEG16			
Explanation	PAGE		Use of external control		Setting the output of external control		S-Plasma ion			
Indication and Details	2	Indication	Details	Indication	Details	0	Thermo on	0	Disuse	
		0	Disuse	Slave, Existing Control						
		1	On/Off							
		2	Off							
		3	Window	Master, Existing Control						
		4	Disuse							
		5	On/Off							
		6	Off	Slave, Reverse Control						
		7	Window							
		8	Disuse							
		9	On/Off	Master, Reverse Control						
		A	Off							
		B	Window							
		C	Disuse	Master, Reverse Control						
		D	On/Off							
E	Off									
F	Window									
Option	SEG17		SEG18		SEG19		SEG20			
Explanation	Buzzer control		Number of hours using filter		PAGE		control of a remote controller			
Indication and Details	0	Use of buzzer	2	1000 Hour	3	Indication	Details	0 or 1	Indoor 1	
								2	Indoor 2	
	1	Non use of buzzer	6	2000 Hour				3	Indoor 3	
4	Indoor 4									
Option	SEG21		SEG22		SEG23		-			
Explanation	Heating setting compensation		RESERVED		Away Set OFF Timer		-			
Indication and Details	Indication	Details			0	Disuse	Indication	Details	-	
									0 or 1	Auto Set OFF 30Min.
									2	Auto Set OFF 60Min.
									3	Auto Set OFF 120Min.
4	Auto Set OFF 180Min.									

5 Press the  button to save and complete the option setting.



6 Press the  button to exit to normal mode.

- Level control : The centralized controller can limit the functions and inputs of connected products with this function enabled. [Example: Operation mode limit (Cooling only/Heating only/No limitation), Heating temperature upper limit, Cooling temperature lower limit] To enable 'Level control' when applying the DPM with the centralized controller, appoint the master (Set 'Use of external control [SEG14] option to 4 or higher).

- Example : When installing DPM (1 Outdoor unit with 4 indoor units)

Condition		SEG 14 Setting				Result
External control	Level control	Indoor 1	Indoor 2	Indoor 3	Indoor 4	
Default		Not set (0)				Slave (All)
Disuse	Use	4	Not set (0)	Not set (0)	Not set (0)	Master (Indoor 1), Slave (Indoor 2,3,4)
Use (Indoor 3)	Disuse	Not set (0)	Not set (0)	1~3	Not set (0)	Slave (All)
Use (Indoor 4)	Use	Not set (0)	Not set (0)	Not set (0)	5~7	Master (Indoor 4), Slave (Indoor 1,2,3)

NOTE

- Press  button anytime during setup to exit without setting.
- Option code will not be applied if you don't press  button.
- Setting Installation option code is available only with a master wired remote controller.
- Setting Installation option code is available when there is one on one connection between a wired remote controller and an indoor unit.

Emergency Temperature Output (ETO) function

CAUTION

- In order to deploy the ETO function, the MIM-B14, an external contact interface module, must be installed in each indoor unit.
- The ETO is a concept of emergency operation of indoor units. If the indoor unit 1 (main indoor unit) stops because of an error, the indoor unit 2 (sub indoor unit) starts to operate.
- Basically, the indoor unit 2 operates in the previous mode. [For the first time operation, it starts in 24 °C (75 °F) Auto mode.]
- To set more detailed operation conditions for the indoor unit 2, use the S-net Pro.

Setting up the ETO

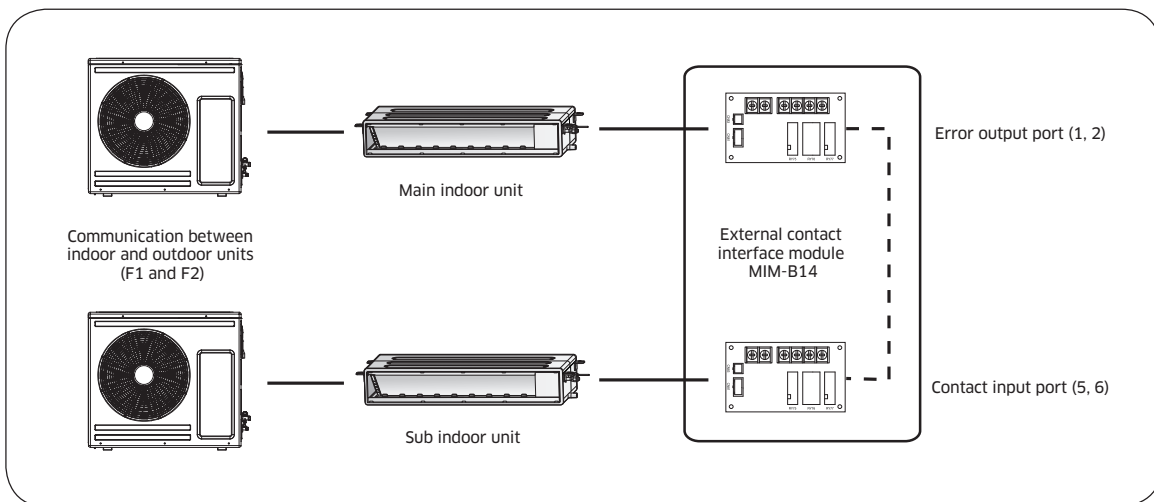

Installation Procedure

1 Main indoor unit

- Disable the external contact control (Default).
- Connect the S-net pro2 to F1 and F2.
- Enable the ETO function and set the temperature and time.

2 Sub indoor unit

- (Required) Enable the external contact control (with the installation option SEG14 - Reverse Control).
- Connect the S-net pro2 to F1 and F2.
- Enable the entrance control and set the mode, set temperature, and fan speed.

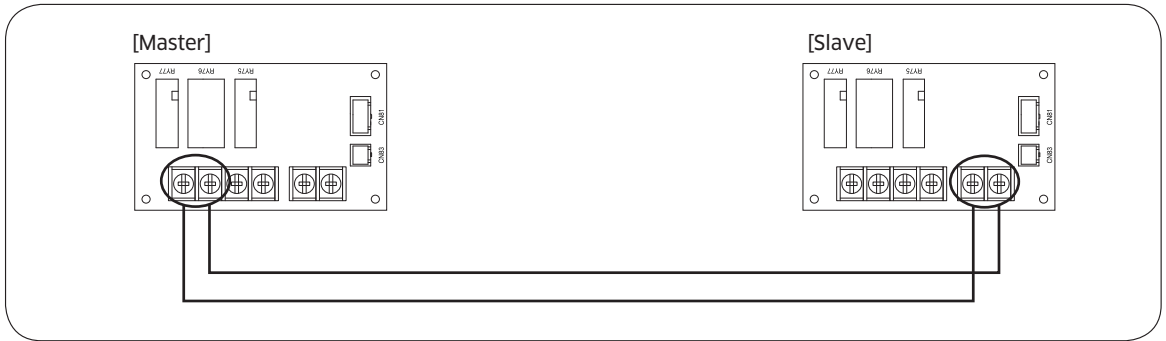

ETO operation specifications

1 Main indoor unit

- Based on the external contact control settings, the main indoor unit decides whether to generate output when an error (indoor unit stop) occurs.
- Based on the ETO settings, the main indoor unit decides whether to generate output according to the temperature and time conditions.

2 Sub indoor unit





























- Based on the entrance control settings, the sub indoor unit decides the mode, set temperature, and fan speed when contact inputs are given.

	Enable of ETO	Enable of external contact	Error port output
Main indoor unit	X	X	N/A
	X	O	Output due to an error
	O	X	Output by ETO entrance conditions (temperature / time / error occurrence)
	O	O	Output by ETO entrance conditions (temperature / time / error occurrence) * Ready to control the main contact input

	Enable of entrance control	Enable of external contact	Operation when outputting Main
Sub indoor unit	X	X	N/A
	X	O	On with the previous operation conditions
	O	O	On with the entrance control enabled

Troubleshooting

- If an error occurs during the operation, one or more LED flickers and the operation is stopped except the LED.
- If you re-operate the air conditioner, it operates normally at first, then detect an error again.

Abnormal conditions	Indicators					Remarks
	Concealed Type					
	Green	Red				
	Standard Type					
						
	Power reset		X	X	X	
Error of Room sensor in the indoor unit(Open/Short)	X	X		X	X	
Error of EVA-IN,EVA-OUT sensor in the indoor unit(Open/Short)		X		X	X	
Error of Fan motor in the indoor unit	X	X	X		X	
Error of Outdoor or Terminal Block Thermal Fuse(Open)	X	X				
Clogging of outdoor's service valve		X	X			
Detection of the float switch	X	X	X			
Error of EEPROM or OPTION SETTING						
1. No communication for 2 minutes between indoor units (Communication error for more than 2 minutes) 2. Indoor unit receiving the communication error from outdoor unit 3. Outdoor unit tracking 3 minutes error 4. When sending the communication error from the outdoor unit, the mismatching of the communication numbers and installed numbers after completion of tracking. (Communication error for more than 2 minutes)	X	X			X	1. Indoor unit error (Display is unrelated with operation) 2. Outdoor unit error (Display is unrelated with operation)

 On
  Flickering
  Off

If you turn off the air conditioner when the LED is flickering, the LED is also turned off.

Troubleshooting

- If an error occurs,  is displayed on the wired remote controller. If you would like to see an error code, press the Test button.

Display	Explanation	Remark
801	Communication Error between indoor and outdoor unit	
821	Error of Room sensor in the indoor unit(Open/Short)	
822	Error of Eva In sensor in the indoor unit(Open/Short)	
823	Error of Eva Out sensor in the indoor unit(Open/Short)	
853	2nd Detection of the float switch	
854	Error of Fan motor in the indoor unit	
862	EEPROM error	
863	EEPROM option setting error	
898	Error of Terminal Block's Thermal Fuse(Open)	
202	No communication for 2minutes between indoor units(Communication error for more than 2minutes)	
422	Clogging of outdoor's service valve	
557	Option code miss matching among the indoors (only for DPM)	Check indoor option code
601	Error of communication down between the indoor unit and wired remote controller after 3minutes.	Wired remote controller error
604	Error of communication down between the indoor unit and wired remote controller after completion of 10 times tracking.	
606	COM1/COM2 Cross-installed error	
607	Error of master wired remote controller and slave wired remote controller setting	



This appliance is filled with R-32.