

SAMSUNG

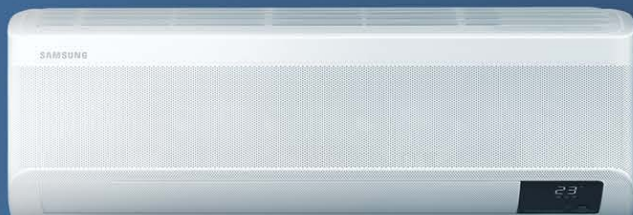

Climate Solutions
Price List

EUROS - v2.0 2021/22



21/22

v2.0 Contents

Type	Product	Description	Page
	SPLIT	Quick Price guide - Single Split Systems	2
	SPLIT	Quick Price guide - DPM Twin, Triple, Quad systems	3
Residential	RAC	Small capacity high wall systems	4-5
Commercial Single Split Systems	SPLIT	360 cassette - Circular	6
	SPLIT	4way cassette - WindFree™	7
	SPLIT	4way mini cassette - WindFree™	8
	SPLIT	1way cassette - WindFree™	8
	SPLIT	Ceiling Suspended	9
	SPLIT	Console Floor & Ceiling/Floor	10
	SPLIT	High Wall - WindFree™ 2.5-7kW and 10kW Std	11
	SPLIT	MSP Duct S	12
	SPLIT	Slim Duct	13
	SPLIT	HSP Duct	13
	SPLIT	High Efficiency Cassette & Ducted	14
	SPLIT	High Efficiency Wall	15
	SPLIT	PAC Floor Cabinet	15
	SPLIT	Accessories & Controls	16
	Commercial Twin, Triple & Quad systems	DPM	Twin Triple Quad - 4way mini cassette
DPM		Twin Triple Quad - 1way cassette	17
DPM		Twin Triple Quad - 4way cassette	18
DPM		Twin Triple Quad - 360 cassette	18
DPM		Twin Triple Quad - Slim Duct	19
DPM		Twin Triple Quad - MSP Duct S	20
DPM		Twin Triple Quad - Wall	21
DPM		Twin Triple Quad - Ceiling	22
DPM		Twin Triple Quad - Floor Console	22
DPM		Twin Triple Quad - Accessories	23
Mini-multi split systems	FJM	Outdoor units	24
	FJM	Wall indoor units (from RAC range)	24
	FJM	Console & Ducted indoor units	25
	FJM	4way cassette indoor units - WindFree™ & Standard	25
	FJM	1way cassette indoor units - WindFree™ & Standard	25
Ventilation	ERV	ERV - Energy Recovery Ventilators	26
	AHU	AHU Kits	26
VRF systems	DVM	Eco Outdoor units - 2pipe / 3pipe	28
	DVM	Water condenser units	28
	DVM	2-pipe Heat Pump Outdoor units	29
	DVM	3-pipe Heat Recovery Outdoor units	29
	DVM	Cassette Indoor units (360 & WindFree™)	30
	DVM	1way cassette & Slim Duct indoor units	31
	DVM	Ducted Indoor units	32
	DVM	Large Ducted Indoor units	32
	DVM	Ceiling Indoor units	33
	DVM	Console/Floor Indoor units	33
	DVM	Floor uncased & PAC Floor Cabinet Indoor units	33
	DVM	Wall indoor units - WindFree™ & Standard	34
	DVM	EHS HYDRO Indoor units	34
	DVM	MCU & Branch Kits	35
	DVM	Panels & Accessories	35
	DVM	Controls	36
	DVM	New vs Old model quick reference guide	37
CHILLER	CHILLER	DVM Chiller Outdoor units	38
	CHILLER	DVM Chiller FCU's	39
	Partner Portal - info and access instructions		40-41

List Price Quick Guide - RAC & Commercial Single Split systems



	R32 RAC	2.5kW	3.5kW	5kW	6.5kW	Control option
	Entry AR30 High Wall	€493	€551			infra-red control only
	Luzon High Wall	€551	€611	€941	€1,242	infra-red control standard Wired remote via interface
	Cebu High Wall	€602	€670	€1,031	€1,366	infra-red control standard Wired remote via interface
	Comfort WindFree High Wall	€720	€788	€1,125	€1,487	infra-red control standard Wired remote via interface
	Avant WindFree High Wall	€876	€963	€1,263	€1,638	infra-red control standard Wired remote via interface
	Elite WindFree High Wall	€1,071	€1,179			infra-red control standard Wired remote via interface
	Pure WindFree High Wall	€1,096	€1,205			infra-red control standard Wired remote via interface

1phase



3phase



	R32 SPLIT	2.5kW	3.5kW	5kW	7.1kW	10kW	12kW	14kW	Control	R410A	16kW	18kW	20kW	25kW
	360 Cassette				€2,123	€2,561	€2,831	€3,096	MWR-WG00JN standard					
	1way Cassette WindFree	€1,352	€1,446						MWR-WG00JN standard					
	4way Mini WindFree	€1,200	€1,318	€1,506	€1,854				MWR-WG00JN standard					
	4way Cassette WindFree			€1,659	€1,926	€2,356	€2,600	€2,854	MWR-WG00JN standard					
	Slim Duct	€1,164	€1,248	€1,408	€1,688				MWR-WG00JN standard					
	MSP Duct S		€1,257	€1,398	€1,699	€2,217	€2,441	€2,731	MWR-WG00JN standard					
	HSP Ducted								MWR-WG00JN standard	HSP Ducted		€4,639	€4,791	€5,380
	High Wall WindFree	€1,044	€1,128	€1,344	€1,642				Infra-red std 10kW wired as standard					
	High Wall					€2,262								
	Ceiling			€1,315	€1,575	€2,654	€2,944	€3,259	8kW Infrared std 9kW wired as standard	Ceiling	€3,493			
	Floor Console	€1,016	€1,172	€1,373					Infra-red as standard					

* Prices are 1phase models (up to 14kW), 3phase 16-25kW, include Fascia (where applicable) and a wired remote (MWR-WG00JN) - 3phase models (10-14kW) will cost extra

Remote Controller options

		List Price	
	AR-EH03E AR-KH03E (360)	Infra-red wireless Wall, Ceiling and floor units as std. optional for 1way, 4way, 360 cassettes 360 cassette has specific model	€39
	MWR-WG00JN	Premium wired controller - for all models (RAC will require interface kit)	€104
	MWR-SH11N	Simple Touch wired controller - for all models (RAC will require interface kit)	€101

List Price Quick Guide - DPM Twin, Triple & Quad systems



1phase										3phase					
R32										R410A					
	7kW TWIN	10kW TWIN	10kW TRIPLE	12kW TRIPLE	12kW QUAD	14kW TWIN	14kW TRIPLE	14kW QUAD		20kW TWIN	20kW TRIPLE	20kW QUAD	25kW TWIN	25kW QUAD	
1way Cassette WindFree	2x3.5 €2,542		3x3.5 €3,577		4x3.5 €4,433			4x3.5 €4,647							
4way Mini WindFree	2x3.5 €2,286	2x5.0 €2,793	3x3.5 €3,193	3x5.0 €3,549	4x3.5 €3,921	2x7.1 €3,381	3x5.0 €3,763	4x3.5 €4,135			3x7.1 €5,016	4x5.0 €5,332		4x7.1 €6,082	
4way Cassette WindFree		2x5.0 €3,099		3x5.0 €4,008		2x7.1 €3,525	3x5.0 €4,222			2x10.0 €4,568	3x7.1 €5,232	4x5.0 €5,944	2x12.0 €5,058	4x7.1 €6,370	
360 Cassette						2x7.1 €3,919				2x10.0 €4,978	3x7.1 €5,823		2x12.0 €5,520	4x7.1 €7,158	
Slim Duct	2x3.5 €2,146	2x5.0 €2,597	3x3.5 €2,983	3x5.0 €3,255	4x3.5 €3,641	2x7.1 €3,049	3x5.0 €3,469	4x3.5 €3,855			3x7.1 €4,518	4x5.0 €4,940		4x7.1 €5,418	
MSP Duct S	2x3.5 €2,164	2x5.0 €2,577	3x3.5 €3,010	3x5.0 €3,225	4x3.5 €3,677	2x7.1 €3,071	3x5.0 €3,439	4x3.5 €3,891		2x10.0 €4,290	3x7.1 €4,551	4x5.0 €4,900	2x12.0 €4,740	4x7.1 €5,462	
Ceiling		2x5.0 €2,619		3x5.0 €3,288		2x7.1 €3,031	3x5.0 €3,502			2x10.0 €5,164	3x7.1 €4,491	4x5.0 €4,984	2x12.0 €5,746	4x7.1 €5,382	
High Wall WindFree	2x3.5 €1,906	2x5.0 €2,469	3x3.5 €2,623	3x5.0 €3,063	4x3.5 €3,161	2x7.1 €2,957	3x5.0 €3,277	4x3.5 €3,375			3x7.1 €4,380	4x5.0 €4,684		4x7.1 €5,234	
High Wall										2x10.0 €4,380					

R410A only													
Floor Console	2x3.5 €2,144	2x5.0 €2,661	3x3.5 €2,984	3x5.0 €3,368	4x3.5 €3,652		3x5.0 €3,576	4x3.5 €3,860					4x5.0 €5,216

NOTE: Floor console on DPM systems uses R410A refrigerant only, due to BS EN 378 Regulation

* Prices are 1phase models (up to 14kW), 3phase 16-25kW, include Fascia (where applicable) and a wired remote (MWR-WG00JN) - 3phase models (10-14kW) will cost extra

* Prices include associated branch pipe kit and 1 remote controller - **DPM systems must be installed in a single room/area**

DPM Piping Limitations

	R32		R410A
	7,10 & 12kW OU	14kW OU	20 & 25kW OU
Total Pipe length (all lengths combined)	50m	75m	75m
Max. Main pipe length (L ₁)	30m	50m	75m
Max. Leg length after branch pipe	15m		
Max. difference between leg length (e.g. L ₂ -L ₃)	5m		
Max. distance between Indoor units (D)	10m		
Max. height between Indoors & outdoor (h ₁)	30m		
Max. height difference between Indoors (h ₂)	0.5m		

* Indoor units should be installed in one area which is not divided by a wall & controlled via 1 remote

TWIN

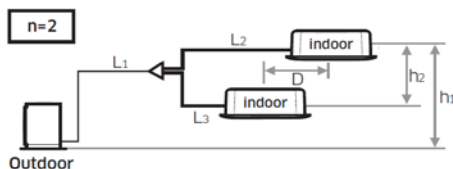

TRIPLE

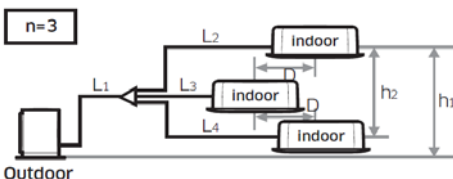

QUAD

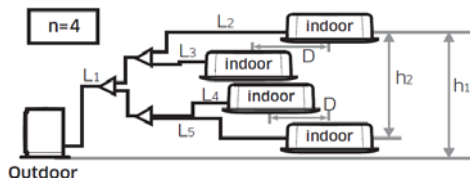



High Wall System

- AR30 - Entry level

1 PHASE - R32

Model Reference	Description	Cool	Heat	SEER	SCoP	Max Fuse	Pipe size Liq, Gas	Max pipe length (height)	LIST PRICE €
AR09TXHQBWKXEU	Inverter Heat Pump R32 Outdoor	2.6kW	2.9kW	6.3	4.0	10A	1/4", 3/8"	25m (10m)	287.00
AR09TXHQBKNEU	AR30 High Wall Unit	(0.9-3.4kW)	(0.8-3.4kW)	A++	A+				206.00
System Price									493.00

AR12TXHQBWKXEU	Inverter Heat Pump R32 Outdoor	3.5kW	3.8kW	6.1	3.9	10A	1/4", 3/8"	25m (10m)	320.00
AR12TXHQBKNEU	AR30 High Wall Unit	(1.1-4.2kW)	(1.1-4.2kW)	A++	A				231.00
System Price									551.00

NOTE: No hard-wired control option - Infra-red only



Luzon High Wall System

- Standard Wall mounted (wired control option via interface)

1 PHASE - R32

Model Reference	Description	Cool	Heat	SEER	SCoP	Max Fuse	Pipe size Liq, Gas	Max pipe length (height)	LIST PRICE €
AR09TXHZAWKXEU	Inverter Heat Pump R32 Outdoor	2.5kW	3.2kW	6.7	4.0	10A	1/4", 3/8"	15m (8m)	316.00
AR09TXHZAWKNEU	Luzon High Wall Unit	(0.9-3.4kW)	(0.9-4.5kW)	A++	A+				235.00
System Price									551.00

AR12TXHZAWKXEU	Inverter Heat Pump R32 Outdoor	3.5kW	3.5kW	6.5	4.0	10A	1/4", 3/8"	15m (8m)	351.00
AR12TXHZAWKNEU	Luzon High Wall Unit	(0.9-4.0kW)	(0.9-5.0kW)	A++	A+				260.00
System Price									611.00

AR18TXHZAWKXEU	Inverter Heat Pump R32 Outdoor	5.0kW	6.0kW	6.8	3.8	13A	1/4", 1/2"	30m (15m)	540.00
AR18TXHZAWKNEU	Luzon High Wall Unit	(1.6-6.7kW)	(1.3-8.0kW)	A++	A				401.00
System Price									941.00

AR24TXHZAWKXEU	Inverter Heat Pump R32 Outdoor	6.5kW	7.4kW	6.4	3.8	16A	1/4", 5/8"	30m (15m)	712.00
AR24TXHZAWKNEU	Luzon High Wall Unit	(1.4-7.6kW)	(1.2-9.4kW)	A++	A				530.00
System Price									1,242.00



Cebu High Wall System

- Standard Wall mounted with Wi-Fi Connectivity (wired control option via interface)

1 PHASE - R32

Model Reference	Description	Cool	Heat	SEER	SCoP	Max Fuse	Pipe size Liq, Gas	Max pipe length (height)	LIST PRICE €
AR09TXFYAWKXEU	Inverter Heat Pump R32 Outdoor	2.5kW	3.2kW	6.7	4.0	10A	1/4", 3/8"	15m (8m)	344.00
AR09TXFYAWKNEU	Cebu Standard High Wall Unit	(0.9-3.35kW)	(0.9-4.5kW)	A++	A+				258.00
System Price									602.00

AR12TXFYAWKXEU	Inverter Heat Pump R32 Outdoor	3.5kW	3.5kW	6.5	4.0	10A	1/4", 3/8"	15m (8m)	383.00
AR12TXFYAWKNEU	Cebu Standard High Wall Unit	(0.9-4.0kW)	(0.9-5.0kW)	A++	A+				287.00
System Price									670.00

AR18TXFYAWKXEU	Inverter Heat Pump R32 Outdoor	5.0kW	6.0kW	6.8	3.8	13A	1/4", 1/2"	30m (15m)	590.00
AR18TXFYAWKNEU	Cebu Standard High Wall Unit	(1.6-6.7kW)	(1.3-8.0kW)	A++	A				441.00
System Price									1,031.00

AR24TXFYAWKXEU	Inverter Heat Pump R32 Outdoor	6.5kW	7.4kW	6.4	3.8	16A	1/4", 5/8"	30m (15m)	783.00
AR24TXFYAWKNEU	Cebu Standard High Wall Unit	(1.4-7.6kW)	(1.2-9.4kW)	A++	A				583.00
System Price									1,366.00

New PM1.0 filter model

PURE WindFree™ High Wall System

- Draft Free operation with microholes, PM1.0 Filter, Motion Sensor & Wi-Fi connectivity (wired control option via interface)

1 PHASE - R32

Model Reference	Description	Cool	Heat	SEER	SCoP	Max Fuse	Pipe size Liq, Gas	Max pipe length (height)	LIST PRICE €
AR09AXKAAWKNEU	Inverter Heat Pump R32 Outdoor	2.5kW	3.2kW	7.9	5.2	10A	1/4", 3/8"	15m (8m)	445.00
AR09AXKAAWKXEU	Pure WindFree High Wall Unit	(0.9-3.4kW)	(0.7-6.5kW)	A++	A+++				651.00
System Price									1,096.00

AR12AXKAAWKNEU	Inverter Heat Pump R32 Outdoor	3.5kW	4.0kW	7.2	5.2	13A	1/4", 3/8"	15m (8m)	484.00
AR12AXKAAWKXEU	Pure WindFree High Wall Unit	(0.9-4.4kW)	(0.7-6.8kW)	A++	A+++				721.00
System Price									1,205.00





COMFORT WindFree™ High Wall System

- Draft Free operation with 23,000 microholes & Wi-Fi connectivity (wired control option via interface)

1 PHASE - R32

Model Reference	Description	Cool	Heat	SEER	SCoP	Max Fuse	Pipe size Liq, Gas	Max pipe length (height)	LIST PRICE €	
AR09TXFCAWKXEU	Inverter Heat Pump R32 Outdoor	2.5kW	3.2kW	6.7	4.0	10A	1/4", 3/8"	15m (8m)	393.00	
AR09TXFCAWKNEU	Comfort WindFree High Wall Unit	(0.9-3.35kW)	(0.9-4.5kW)	A++	A+				327.00	
									System Price	720.00
AR12TXFCAWKXEU	Inverter Heat Pump R32 Outdoor	3.5kW	3.5kW	6.5	4.0	10A	1/4", 3/8"	15m (8m)	435.00	
AR12TXFCAWKNEU	Comfort WindFree High Wall Unit	(0.9-4.0kW)	(0.9-5.0kW)	A++	A+				353.00	
									System Price	788.00
AR18TXFCAWKXEU	Inverter Heat Pump R32 Outdoor	5.0kW	6.0kW	6.8	3.8	13A	1/4", 1/2"	30m (15m)	650.00	
AR18TXFCAWKNEU	Comfort WindFree High Wall Unit	(1.6-6.7kW)	(1.3-8.0kW)	A++	A				475.00	
									System Price	1,125.00
AR24TXFCAWKXEU	Inverter Heat Pump R32 Outdoor	6.5kW	7.4kW	6.4	3.8	16A	1/4", 5/8"	30m (15m)	840.00	
AR24TXFCAWKNEU	Comfort WindFree High Wall Unit	(1.4-7.6kW)	(1.2-9.4kW)	A++	A				647.00	
									System Price	1,487.00



AVANT WindFree™ High Wall System

- Draft Free operation with 23,000 microholes, Eco-Filter & Wi-Fi connectivity (wired control option via interface)

1 PHASE - R32

Model Reference	Description	Cool	Heat	SEER	SCoP	Max Fuse	Pipe size Liq, Gas	Max pipe length (height)	LIST PRICE €	
AR09TXEAAWKXEU	Inverter Heat Pump R32 Outdoor	2.5kW	3.2kW	7.9	4.6	10A	1/4", 3/8"	15m (8m)	499.00	
AR09TXEAAWKNEU	Avant WindFree High Wall Unit	(0.9-3.35kW)	(0.72-5.0kW)	A++	A++				377.00	
									System Price	876.00
AR12TXEAAWKXEU	Inverter Heat Pump R32 Outdoor	3.5kW	4.0kW	7.3	4.6	10A	1/4", 3/8"	15m (8m)	550.00	
AR12TXEAAWKNEU	Avant WindFree High Wall Unit	(0.99-4.0kW)	(0.74-5.5kW)	A++	A++				413.00	
									System Price	963.00
AR18TXEAAWKXEU	Inverter Heat Pump R32 Outdoor	5.0kW	6.0kW	6.8	4.1	13A	1/4", 1/2"	30m (15m)	695.00	
AR18TXEAAWKNEU	Avant WindFree High Wall Unit	(1.6-6.7kW)	(1.3-8.0kW)	A++	A+				568.00	
									System Price	1,263.00
AR24TXEAAWKXEU	Inverter Heat Pump R32 Outdoor	6.5kW	7.4kW	6.4	4.0	16A	1/4", 5/8"	30m (15m)	883.00	
AR24TXEAAWKNEU	Avant WindFree High Wall Unit	(1.4-7.6kW)	(1.2-9.7kW)	A++	A+				755.00	
									System Price	1,638.00



ELITE WindFree™ High Wall System

- Draft Free operation with 23,000 microholes, Eco-Filter, Motion Sensor & Wi-Fi connectivity (wired control option via interface)

1 PHASE - R32

Model Reference	Description	Cool	Heat	SEER	SCoP	Max Fuse	Pipe size Liq, Gas	Max pipe length (height)	LIST PRICE €	
AR09TXCAAWKXEU	Inverter Heat Pump R32 Outdoor	2.5kW	3.2kW	8.8	5.1	10A	1/4", 3/8"	15m (8m)	636.00	
AR09TXCAAWKNEU	Elite WindFree High Wall Unit	(0.9-3.6kW)	(0.8-7.1kW)	A+++	A+++				435.00	
									System Price	1,071.00
AR12TXCAAWKXEU	Inverter Heat Pump R32 Outdoor	3.5kW	4.0kW	8.5	5.1	13A	1/4", 3/8"	15m (8m)	705.00	
AR12TXCAAWKNEU	Elite WindFree High Wall Unit	(0.9-4.8kW)	(0.8-7.3kW)	A+++	A+++				474.00	
									System Price	1,179.00

*All RAC units supplied with infra-red remote control as standard

Accessories for RAC High Wall LIST PRICE €

MIM-A00N	Interface to connect NASA wired remote controller to RAC High Wall (Check suitability)	26.00
MWR-WG00JN	LCD COLOUR PREMIUM Wired Controller (NASA)	104.00
MIM-R10N	Interface to connect RAC High Wall to Central Control network (Check outdoor suitability)	191.00

COMMERCIAL SPLIT SYSTEM

Air Conditioner



360 Cassette

1 PHASE - R32		Cool	Heat	SEER	SCoP	Max. Fuse	Pipe size Liq, Gas	Max. pipe length (height)	LIST PRICE €
Model Reference	Description								

AC071RXADKG/EU	1ph Inverter Heat Pump R32 Outdoor	7.1kW	8.0kW	6.7	4.2	20A	1/4", 5/8"	50m (30m)	1,105.00
AC071RN4PKG/EU	360 Cassette indoor	(1.5-8.7kW)	(1.9-9kW)	A++	A+				747.00
PC4NUNMAN	360 Cassette Fascia Panel Round WHITE								167.00
MWR-WG00JN	LCD COLOUR Wired Controller (NASA)								104.00

System Price 2,123.00

AC100RXADKG/EU	1ph Inverter Heat Pump R32 Outdoor	10.0kW	11.2kW	6.8	4.3	30A	3/8", 5/8"	50m (30m)	1,496.00
AC100RN4PKG/EU	360 Cassette indoor	(3-12kW)	(2.2-15.5kW)	A++	A+				794.00
PC4NUNMAN	360 Cassette Fascia Panel Round WHITE								167.00
MWR-WG00JN	LCD COLOUR Wired Controller (NASA)								104.00

System Price 2,561.00

AC120RXADKG/EU	1ph Inverter Heat Pump R32 Outdoor	12.0kW	13.2kW	6.0	4.0	30A	3/8", 5/8"	50m (30m)	1,678.00
AC120RN4PKG/EU	360 Cassette indoor	(3.5-13.5kW)	(3.5-15.5kW)	A+	A+				882.00
PC4NUNMAN	360 Cassette Fascia Panel Round WHITE								167.00
MWR-WG00JN	LCD COLOUR Wired Controller (NASA)								104.00

System Price 2,831.00

AC140RXADKG/EU	1ph Inverter Heat Pump R32 Outdoor	13.4kW	15.5kW	6.4	4.1	40A	3/8", 5/8"	75m (30m)	1,892.00
AC140RN4PKG/EU	360 Cassette indoor	(3.5-15.5kW)	(3.5-18kW)						933.00
PC4NUNMAN	360 Cassette Fascia Panel Round WHITE								167.00
MWR-WG00JN	LCD COLOUR Wired Controller (NASA)								104.00

System Price 3,096.00

3 PHASE - R32		Cool	Heat	SEER	SCoP	Max. Fuse	Pipe size Liq, Gas	Max. pipe length (height)	LIST PRICE €
Model Reference	Description								

AC100RXADNG/EU	3ph Inverter Heat Pump R32 Outdoor	10.0kW	11.2kW	6.8	4.3	20A/ph	3/8", 5/8"	50m (30m)	1,579.00
AC100RN4PKG/EU	360 Cassette indoor	(3-12kW)	(2.2-15.5kW)	A++	A+				794.00
PC4NUNMAN	360 Cassette Fascia Panel Round WHITE								167.00
MWR-WG00JN	LCD COLOUR Wired Controller (NASA)								104.00

System Price 2,644.00

AC120RXADNG/EU	3ph Inverter Heat Pump R32 Outdoor	12.0kW	13.2kW	6.0	4.0	20A/ph	3/8", 5/8"	50m (30m)	1,748.00
AC120RN4PKG/EU	360 Cassette indoor	(3.5-13.5kW)	(3.5-15.5kW)	A+	A+				882.00
PC4NUNMAN	360 Cassette Fascia Panel Round WHITE								167.00
MWR-WG00JN	LCD COLOUR Wired Controller (NASA)								104.00

System Price 2,901.00

AC140RXADNG/EU	3ph Inverter Heat Pump R32 Outdoor	13.4kW	15.5kW	6.4	4.1	20A/ph	3/8", 5/8"	75m (30m)	1,957.00
AC140RN4PKG/EU	360 Cassette indoor	(3.5-15.5kW)	(3.5-18kW)						933.00
PC4NUNMAN	360 Cassette Fascia Panel Round WHITE								167.00
MWR-WG00JN	LCD COLOUR Wired Controller (NASA)								104.00

System Price 3,161.00

Accessories for 360 Cassette		LIST PRICE €
------------------------------	--	--------------

MWR-WG00JN	LCD COLOUR PREMIUM Wired Controller (NASA)	104.00
MWR-SH11N	Simplified Wired Remote Controller (NASA)	101.00
PC4NUDMAN	360 Cassette Fascia Panel - Square WHITE	167.00
PC4NBDMAN	360 Cassette Fascia Panel - Square BLACK	167.00
PC4NBNMAN	360 Cassette Fascia Panel - Round BLACK	167.00
PC6EUCMAN	360 Cassette Fascia Panel Square - PURE Filter	528.00
PC6EUXMAN	360 Cassette Fascia Panel Square - AutoLIFT	496.00
MCR-SME	Motion detect sensor for 360 Cassette - for SQUARE panel	77.00
MSD-CAN1	S-Plasma Ion Kit for 4way & 360Cassette & Large Ceiling	76.00
AR-KH03E	360 Wireless Remote controller (SPLIT/DVM)	39.00
MIM-H04EN	Wi-Fi Receiver 2.0 for NASA SPLIT/DVM IU	152.00
MRW-TA	Remote Temperature Sensor	25.00

COMMERCIAL SPLIT SYSTEM

Air Conditioner

R32



4way Cassette - WindFree™

1 PHASE - R32		Cool	Heat	SEER	SCoP	Max. Fuse	Pipe size Liq, Gas	Max. pipe length (height)	LIST PRICE €
Model Reference	Description								
AC052RXADKG/EU	1ph Inverter Heat Pump R32 Outdoor	5.0kW	6.0kW	7.6	4.3	20A	1/4", 1/2"	30m (20m)	853.00
AC052RN4DKG/EU	WindFree 4-Way Cassette (840mm x 840mm)	(1-6.5kW)	(1-7kW)	A++	A+				535.00
PC4NUFMAN	WindFree 4-Way Cassette Fascia Panel								167.00
MWR-WG00JN	LCD COLOUR Wired Controller (NASA)								104.00
System Price									1,659.00

AC071RXADKG/EU	1ph Inverter Heat Pump R32 Outdoor	7.1kW	8.0kW	6.7	4.2	20A	1/4", 5/8"	50m (30m)	1,105.00
AC071RN4DKG/EU	WindFree 4-Way Cassette (840mm x 840mm)	(1.5-8.7kW)	(1.9-9kW)	A++	A+				550.00
PC4NUFMAN	WindFree 4-Way Cassette Fascia Panel								167.00
MWR-WG00JN	LCD COLOUR Wired Controller (NASA)								104.00
System Price									1,926.00

AC100RXADKG/EU	1ph Inverter Heat Pump R32 Outdoor	10.0kW	11.2kW	7.0	4.3	25A	3/8", 5/8"	50m (30m)	1,496.00
AC100RN4DKG/EU	WindFree 4-Way Cassette (840mm x 840mm)	(3-12kW)	(2.2-15.5kW)	A++	A+				589.00
PC4NUFMAN	WindFree 4-Way Cassette Fascia Panel								167.00
MWR-WG00JN	LCD COLOUR Wired Controller (NASA)								104.00
System Price									2,356.00

AC120RXADKG/EU	1ph Inverter Heat Pump R32 Outdoor	12.0kW	13.2kW	6.0	4.0	30A	3/8", 5/8"	50m (30m)	1,678.00
AC120RN4DKG/EU	WindFree 4-Way Cassette (840mm x 840mm)	(3.5-13.5kW)	(3.5-15.5kW)	A+	A+				651.00
PC4NUFMAN	WindFree 4-Way Cassette Fascia Panel								167.00
MWR-WG00JN	LCD COLOUR Wired Controller (NASA)								104.00
System Price									2,600.00

AC140RXADKG/EU	1ph Inverter Heat Pump R32 Outdoor	13.4kW	15.5kW	6.6	4.3	40A	3/8", 5/8"	75m (30m)	1,892.00
AC140RN4DKG/EU	WindFree 4-Way Cassette (840mm x 840mm)	(3.5-15.5kW)	(3.5-18kW)						691.00
PC4NUFMAN	WindFree 4-Way Cassette Fascia Panel								167.00
MWR-WG00JN	LCD COLOUR Wired Controller (NASA)								104.00
System Price									2,854.00

3 PHASE - R32		Cool	Heat	SEER	SCoP	Max. Fuse	Pipe size Liq, Gas	Max. pipe length (height)	LIST PRICE €
Model Reference	Description								
AC100RXADNG/EU	3ph Inverter Heat Pump R32 Outdoor	10.0kW	11.2kW	7.0	4.3	20A/ph	3/8", 5/8"	50m (30m)	1,579.00
AC100RN4DKG/EU	WindFree 4-Way Cassette (840mm x 840mm)	(3-12kW)	(2.2-15.5kW)	A++	A+				589.00
PC4NUFMAN	WindFree 4-Way Cassette Fascia Panel								167.00
MWR-WG00JN	LCD COLOUR Wired Controller (NASA)								104.00
System Price									2,439.00

AC120RXADNG/EU	3ph Inverter Heat Pump R32 Outdoor	12.0kW	13.2kW	6.0	4.0	20A/ph	3/8", 5/8"	50m (30m)	1,748.00
AC120RN4DKG/EU	WindFree 4-Way Cassette (840mm x 840mm)	(3.5-13.5kW)	(3.5-15.5kW)	A+	A+				651.00
PC4NUFMAN	WindFree 4-Way Cassette Fascia Panel								167.00
MWR-WG00JN	LCD COLOUR Wired Controller (NASA)								104.00
System Price									2,670.00

AC140RXADNG/EU	3ph Inverter Heat Pump R32 Outdoor	13.4kW	15.5kW	6.6	4.3	20A/ph	3/8", 5/8"	75m (30m)	1,957.00
AC140RN4DKG/EU	WindFree 4-Way Cassette (840mm x 840mm)	(3.5-15.5kW)	(3.5-18kW)						691.00
PC4NUFMAN	WindFree 4-Way Cassette Fascia Panel								167.00
MWR-WG00JN	LCD COLOUR Wired Controller (NASA)								104.00
System Price									2,919.00

Accessories for WindFree 4way Cassette		LIST PRICE €
MWR-WG00JN	LCD COLOUR Wired Controller (NASA)	104.00
MWR-SH11N	Touch Simplified Wired Remote Controller - WindFree™ (NASA)	101.00
PC4NUFMAN	WindFree 4-Way Cassette Fascia Panel	167.00
PC4NUCEAN	WindFree 4-Way Cassette Fascia Panel - PURE Filter	594.00
PC4NUXMAN	WindFree 4-Way Cassette Fascia Panel - AutoLIFT	414.00
MCR-SMC	Motion detect sensor for 4-way wind-free Cassette - for 950x950 panel	77.00
MSD-CAN1	S-Plasma Ion Kit for 4way & 360Cassette & Large Ceiling	76.00
AR-EH03E	WindFree & STANDARD Wireless Remote controller (SPLIT/DVM)	39.00
MIM-H04EN	NEW Wi-Fi Receiver 2.0 for NASA SPLIT/DVM IU	152.00
MRW-TA	Remote Temperature Sensor	25.00

COMMERCIAL SPLIT SYSTEM

Air Conditioner

4way Mini Cassette - WindFree™

R32



1 PHASE - R32									
Model Reference	Description	Cool	Heat	SEER	SCoP	Max. Fuse	Pipe size Liq, Gas	Max. pipe length (height)	LIST PRICE €
AC026RXADKG/EU	1ph Inverter Heat Pump R32 Outdoor	2.6kW	3.4kW	7.1	4.3	13A	1/4", 3/8"	20m (15m)	652.00
AC026RNNDKG/EU	WindFree 4-Way Cassette (575mm x 575mm)	(0.87-4.1kW)	(0.98-4.1kW)	A++	A+				282.00
PC4SUFMAN	WindFree Mini 4-Way Cassette Fascia Panel								162.00
MWR-WG00JN	LCD COLOUR Wired Controller (NASA)								104.00
System Price									1,200.00
AC035RXADKG/EU	1ph Inverter Heat Pump R32 Outdoor	3.5kW	4.0kW	7.0	4.3	13A	1/4", 3/8"	20m (15m)	723.00
AC035RNNDKG/EU	WindFree 4-Way Cassette (575mm x 575mm)	(0.88-4.5kW)	(1-4.8kW)	A++	A+				329.00
PC4SUFMAN	WindFree Mini 4-Way Cassette Fascia Panel								162.00
MWR-WG00JN	LCD COLOUR Wired Controller (NASA)								104.00
System Price									1,318.00
AC052RXADKG/EU	1ph Inverter Heat Pump R32 Outdoor	5.0kW	5.5kW	6.7	4.2	20A	1/4", 1/2"	30m (20m)	853.00
AC052RNNDKG/EU	WindFree 4-Way Cassette (575mm x 575mm)	(1.3-6.2kW)	(1.3-7.5kW)	A++	A+				387.00
PC4SUFMAN	WindFree Mini 4-Way Cassette Fascia Panel								162.00
MWR-WG00JN	LCD COLOUR Wired Controller (NASA)								104.00
System Price									1,506.00
AC071RXADKG/EU	1ph Inverter Heat Pump R32 Outdoor	6.8kW	7.5kW	6.1	3.8	20A	1/4", 5/8"	50m (30m)	1,105.00
AC071RNNDKG/EU	WindFree 4-Way Cassette (575mm x 575mm)	(1.5-8.3kW)	(1.9-9kW)	A++	A				483.00
PC4SUFMAN	WindFree Mini 4-Way Cassette Fascia Panel								162.00
MWR-WG00JN	LCD COLOUR Wired Controller (NASA)								104.00
System Price									1,854.00

Accessories for WindFree 4way mini Cassette									
		LIST PRICE €							
MWR-WG00JN	LCD COLOUR Wired Controller (NASA)	104.00							
MWR-SH11N	Touch Simplified Wired Remote Controller - WindFree™ (NASA)	101.00							
PC4SUFMAN	WindFree Mini 4-Way Cassette Fascia Panel - 620x620	162.00							
MCR-SMD	Motion detect sensor for 4-way wind-free Cassette - for 620x620 panel	77.00							
MSD-CAN1	S-Plasma Ion Kit for 4way & 360Cassette & Large Ceiling	76.00							
AR-EH03E	WindFree & STANDARD Wireless Remote controller (SPLIT/DVM)	39.00							
MIM-H04EN	NEW Wi-Fi Receiver 2.0 for NASA SPLIT/DVM IU	152.00							
MRW-TA	Remote Temperature Sensor	25.00							

1way Cassette - WindFree™

R32



1 PHASE - R32									
Model Reference	Description	Cool	Heat	SEER	SCoP	Max. Fuse	Pipe size Liq, Gas	Max. pipe length (height)	LIST PRICE €
AC026RXADKG/EU	1ph Inverter Heat Pump R32 Outdoor	2.6kW	3.3kW	6.4	4.0	13A	1/4", 3/8"	20m (15m)	652.00
AC026RN1DKG/EU	WindFree 1-Way Cassette	(0.82-3.8kW)	(0.85-4.4kW)	A++	A+				434.00
PC1NWFMAN	WindFree 1-Way Cassette Panel - Medium								162.00
MWR-WG00JN	LCD COLOUR Wired Controller (NASA)								104.00
System Price									1,352.00
AC035RXADKG/EU	1ph Inverter Heat Pump R32 Outdoor	3.5kW	4.0kW	6.2	4.0	13A	1/4", 3/8"	20m (15m)	723.00
AC035RN1DKG/EU	WindFree 1-Way Cassette	(0.98-4.2kW)	(1-5kW)	A++	A+				457.00
PC1NWFMAN	WindFree 1-Way Cassette Panel - Medium								162.00
MWR-WG00JN	LCD COLOUR Wired Controller (NASA)								104.00
System Price									1,446.00

Accessories for WindFree 1way slim Cassette									
		LIST PRICE €							
MWR-WG00JN	LCD COLOUR Wired Controller (NASA)	104.00							
MWR-SH11N	Touch Simplified Wired Remote Controller - WindFree™ (NASA)	101.00							
PC1NWFMAN	WindFree 1-Way Cassette Fascia Panel - Medium	162.00							
PC1NWCMAN	WindFree 1-Way Cassette Fascia Panel - Medium - PURE Filter	496.00							
AR-EH03E	WindFree & STANDARD Wireless Remote controller (SPLIT/DVM)	39.00							
MIM-H04EN	Wi-Fi Receiver 2.0 for NASA SPLIT/DVM IU	152.00							
MRW-TA	Remote Temperature Sensor	25.00							

COMMERCIAL SPLIT SYSTEM

Air Conditioner

Ceiling / Floor

R32



1 PHASE - R32		Cool	Heat	SEER	SCoP	Max. Fuse	Pipe size Liq, Gas	Max. pipe length (height)	LIST PRICE €
---------------	--	------	------	------	------	-----------	--------------------	---------------------------	--------------

Model Reference	Description	Cool	Heat	SEER	SCoP	Max. Fuse	Pipe size Liq, Gas	Max. pipe length (height)	LIST PRICE €
AC052RXADKG/EU	1ph Inverter Heat Pump R32 Outdoor	5.0kW	6.0kW	6.4	3.9	20A	1/4", 1/2"	30m (20m)	853.00
AC052RNCDKG/EU	Under Ceiling / Floor Standing Unit	(1.2-6.5kW)	(1.7-7.7kW)	A++	A				462.00
MR-EH00	Wireless Remote Controller								included
System Price									1,315.00

AC071RXADKG/EU	1ph Inverter Heat Pump R32 Outdoor	7.1kW	8.0kW	5.6	3.9	25A	1/4", 5/8"	50m (30m)	1,105.00
AC071RNCDKG/EU	Under Ceiling / Floor Standing Unit	(1.5-8.7kW)	(1.9-9kW)	A+	A				470.00
MR-EH00	Wireless Remote Controller								included
System Price									1,575.00

Accessories for Ceiling/Floor

Model Reference	Description	LIST PRICE €
MWR-WG00JN	LCD COLOUR Wired Controller (NASA)	104.00
MWR-SH11N	Touch Simplified Wired Remote Controller - WindFree™ (NASA)	101.00
MIM-H04EN	Wi-Fi Receiver 2.0 for NASA SPLIT/DVM IU	152.00

Floor Console

R32



1 PHASE - R32		Cool	Heat	SEER	SCoP	Max. Fuse	Pipe size Liq, Gas	Max. pipe length (height)	LIST PRICE €
---------------	--	------	------	------	------	-----------	--------------------	---------------------------	--------------

AC026RXADKG/EU	1ph Inverter Heat Pump R32 Outdoor	2.6kW	3.56kW	6.4	4.2	13A	1/4", 3/8"	20m (15m)	652.00
AC026RNJDKG/EU	Console Floor Standing Unit	(0.98-3.4kW)	(0.95-4.2kW)	A++	A+				364.00
MR-EH00	Wireless Remote Controller								included
System Price									1,016.00

AC035RXADKG/EU	1ph Inverter Heat Pump R32 Outdoor	3.5kW	4.0kW	6.1	4.1	13A	1/4", 3/8"	20m (15m)	723.00
AC035RNJDKG/EU	Console Floor Standing Unit	(1.15-3.9kW)	(1.05-4.6kW)	A++	A+				449.00
MR-EH00	Wireless Remote Controller								included
System Price									1,172.00

AC052RXADKG/EU	1ph Inverter Heat Pump R32 Outdoor	5.0kW	5.6kW	5.9	4.0	20A	1/4", 1/2"	30m (20m)	853.00
AC052RNJDKG/EU	Console Floor Standing Unit	(1.9-5.5kW)	(1.5-6.5kW)	A+	A+				520.00
MR-EH00	Wireless Remote Controller								included
System Price									1,373.00

Accessories for Console

Model Reference	Description	LIST PRICE €
MWR-WG00JN	LCD COLOUR Wired Controller (NASA)	104.00
MWR-SH11N	Touch Simplified Wired Remote Controller - WindFree™ (NASA)	101.00
MIM-H04EN	Wi-Fi Receiver 2.0 for NASA SPLIT/DVM IU	152.00

COMMERCIAL SPLIT SYSTEM

Air Conditioner

WindFree™ High Wall

R32



1 PHASE - R32		Cool	Heat	SEER	SCoP	Max. Fuse	Pipe size Liq, Gas	Max. pipe length (height)	LIST PRICE €
Model Reference	Description								

AC026RXADKG/EU	1ph Inverter Heat Pump R32 Outdoor	2.6kW	3.3kW	7.0	4.1	13A	1/4", 3/8"	20m (15m)	652.00
AC026TNXDKG/EU	WindFree High Wall Mounted Unit	(0.96-4kW)	(0.75-4kW)	A++	A+				288.00
MWR-WG00JN	LCD COLOUR Wired Controller (NASA)								104.00
System Price									1,044.00

AC035RXADKG/EU	1ph Inverter Heat Pump R32 Outdoor	3.5kW	4.0kW	6.9	4.1	13A	1/4", 3/8"	20m (15m)	723.00
AC035TNXDKG/EU	WindFree High Wall Mounted Unit	(1-4.5kW)	(0.8-4.8kW)	A++	A+				301.00
MWR-WG00JN	LCD COLOUR Wired Controller (NASA)								104.00
System Price									1,128.00

AC052RXADKG/EU	1ph Inverter Heat Pump R32 Outdoor	5.0kW	6.0kW	6.9	3.9	20A	1/4", 1/2"	30m (20m)	853.00
AC052TNXDKG/EU	WindFree High Wall Mounted Unit	(1.5-6.8kW)	(1.0-6.5kW)	A++	A				387.00
MWR-WG00JN	LCD COLOUR Wired Controller (NASA)								104.00
System Price									1,344.00

AC071RXADKG/EU	1ph Inverter Heat Pump R32 Outdoor	7.1kW	8.0kW	6.8	4.0	20A	1/4", 5/8"	50m (30m)	1,105.00
AC071TNXDKG/EU	WindFree High Wall Mounted Unit	(2.0-8.7kW)	(1.6-9kW)	A++	A+				433.00
MWR-WG00JN	LCD COLOUR Wired Controller (NASA)								104.00
System Price									1,642.00

10kW High Wall

R32

10kW high Wall



1 PHASE - R32		Cool	Heat	SEER	SCoP	Max. Fuse	Pipe size Liq, Gas	Max. pipe length (height)	LIST PRICE €
Model Reference	Description								

AC100RXADKG/EU	1ph Inverter Heat Pump R32 Outdoor	9.5kW	10.8kW	5.9	4.0	30A	3/8", 5/8"	50m (30m)	1,496.00
AC100RNTDKG/EU	High Wall Mounted Unit	(3-11kW)	(2.2-15.5kW)	A+	A+				662.00
MWR-WG00JN	LCD COLOUR Wired Controller (NASA)								104.00
System Price									2,262.00

3 PHASE - R32		Cool	Heat	SEER	SCoP	Max. Fuse	Pipe size Liq, Gas	Max. pipe length (height)	LIST PRICE €
Model Reference	Description								

AC100RXADNG/EU	3ph Inverter Heat Pump R32 Outdoor	9.5kW	10.8kW	5.9	4.0	20A/ph	3/8", 5/8"	50m (30m)	1,579.00
AC100RNTDKG/EU	High Wall Mounted Unit	(3-11kW)	(2.2-15.5kW)	A+	A+				662.00
MWR-WG00JN	LCD COLOUR Wired Controller (NASA)								104.00
System Price									2,345.00

Accessories for Wall		LIST PRICE €
----------------------	--	--------------

MWR-WG00JN	LCD COLOUR Wired Controller (NASA)	104.00
MWR-SH11N	Touch Simplified Wired Remote Controller - WindFree™ (NASA)	101.00
AR-EH03E	WindFree & STANDARD Wireless Remote controller (SPLIT/DVM)	39.00
MIM-H04EN	NEW Wi-Fi Receiver 2.0 for NASA SPLIT/DVM IU	152.00

COMMERCIAL SPLIT SYSTEM

Air Conditioner



DUCT S MSP Ducted

1 PHASE - R32										
Model Reference	Description	Cool	Heat	SEER	SCoP	Max. Fuse	Pipe size Liq, Gas	Max. pipe length (height)	LIST PRICE €	
AC035RXADKG/EU	1ph Inverter Heat Pump R32 Outdoor	3.5kW	4.0kW	6.4	4.1	13A	1/4", 3/8"	20m (15m)	723.00	
AC035RNMDKG/EU	Duct S Ducted Unit	(0.8-4kW)	(1.1-4.7kW)	A++	A+				430.00	
MWR-WG00JN	LCD COLOUR Wired Controller (NASA)								104.00	
									System Price	1,257.00
AC052RXADKG/EU	1ph Inverter Heat Pump R32 Outdoor	5.0kW	6.0kW	6.3	4.1	20A	1/4", 1/2"	30m (20m)	853.00	
AC052RNMDKG/EU	Duct S Ducted Unit	(1.2-6.5kW)	(1.1-7.2kW)	A++	A+				441.00	
MWR-WG00JN	LCD COLOUR Wired Controller (NASA)								104.00	
									System Price	1,398.00
AC071RXADKG/EU	1ph Inverter Heat Pump R32 Outdoor	6.8kW	8.0kW	6.1	4.0	20A	1/4", 5/8"	50m (30m)	1,105.00	
AC071RNMDKG/EU	Duct S Ducted Unit	(1.5-8.7kW)	(1.9-9kW)	A++	A+				490.00	
MWR-WG00JN	LCD COLOUR Wired Controller (NASA)								104.00	
									System Price	1,699.00
AC100RXADKG/EU	1ph Inverter Heat Pump R32 Outdoor	10.0kW	11.2kW	5.9	4.0	30A	3/8", 5/8"	50m (30m)	1,496.00	
AC100RNMDKG/EU	Duct S Ducted Unit	(3-12kW)	(2.2-15.5kW)	A+	A+				617.00	
MWR-WG00JN	LCD COLOUR Wired Controller (NASA)								104.00	
									System Price	2,217.00
AC120RXADKG/EU	1ph Inverter Heat Pump R32 Outdoor	12.0kW	13.2kW	5.8	4.0	30A	3/8", 5/8"	50m (30m)	1,678.00	
AC120RNMDKG/EU	Duct S Ducted Unit	(3-13.5kW)	(2.5-17kW)	A+	A+				659.00	
MWR-WG00JN	LCD COLOUR Wired Controller (NASA)								104.00	
									System Price	2,441.00
AC140RXADKG/EU	1ph Inverter Heat Pump R32 Outdoor	13.4kW	15.5kW	6.0	4.0	40A	3/8", 5/8"	75m (30m)	1,892.00	
AC140RNMDKG/EU	Duct S Ducted Unit	(3.5-15.5kW)	(3.5-18kW)						735.00	
MWR-WG00JN	LCD COLOUR Wired Controller (NASA)								104.00	
									System Price	2,731.00
3 PHASE - R32										
Model Reference	Description	Cool	Heat	SEER	SCoP	Max. Fuse	Pipe size Liq, Gas	Max. pipe length (height)	LIST PRICE €	
AC100RXADNG/EU	3ph Inverter Heat Pump R32 Outdoor	10.0kW	11.2kW	5.9	4.0	20A/ph	3/8", 5/8"	50m (30m)	1,579.00	
AC100RNMDKG/EU	Duct S Ducted Unit	(3-12kW)	(2.2-15.5kW)	A+	A+				617.00	
MWR-WG00JN	LCD COLOUR Wired Controller (NASA)								104.00	
									System Price	2,300.00
AC120RXADNG/EU	3ph Inverter Heat Pump R32	12.0kW	13.2kW	5.8	4.0	20A/ph	3/8", 5/8"	50m (30m)	1,748.00	
AC120RNMDKG/EU	Duct S Ducted Unit	(3-13.5kW)	(2.5-17kW)	A+	A+				659.00	
MWR-WG00JN	LCD COLOUR Wired Controller (NASA)								104.00	
									System Price	2,511.00
AC140RXADNG/EU	3ph Inverter Heat Pump R32	13.4kW	15.5kW	6.0	4.0	20A/ph	3/8", 5/8"	75m (30m)	1,957.00	
AC140RNMDKG/EU	Duct S Ducted Unit	(3.5-15.5kW)	(3.5-18kW)						735.00	
MWR-WG00JN	LCD COLOUR Wired Controller (NASA)								104.00	
									System Price	2,796.00
Accessories for Duct S										LIST PRICE €
MWR-WG00JN	LCD COLOUR Wired Controller (NASA)									104.00
MWR-SH11N	Touch Simplified Wired Remote Controller - WindFree™ (NASA)									101.00
MSD-EAN1	S-Plasma Ion Healthy Air Provider for Duct S									76.00
MIM-H04EN	Wi-Fi Receiver 2.0 for NASA SPLIT/DVM IU									152.00
MRK-A10N	DUCT S & Slim Duct Wireless Signal Receiver Kit (requires AR-EH03E)									38.00
MRW-TA	Remote Temperature Sensor									25.00
MDP-G075SP	Drain Pump for DUCT S Ducted Unit (External Assembly)									84.00
MDP-G075SQ	Drain Pump for DUCT S Ducted Unit (Internal Assembly)									84.00

COMMERCIAL SPLIT SYSTEM

Air Conditioner



Slim Ducted

1 PHASE - R32										
Model Reference	Description	Cool	Heat	SEER	SCoP	Max. Fuse	Pipe size Liq, Gas	Max. pipe length (height)	LIST PRICE €	
AC026RXADKG/EU	1ph Inverter Heat Pump R32 Outdoor	2.6kW	3.3kW	6.2	4.0	13A	1/4", 3/8"	20m (15m)	652.00	
AC026RNLDKG/EU	Slim Ducted Unit	(0.8-3.8kW)	(0.98-4.3kW)	A++	A+				408.00	
MWR-WG00JN	LCD COLOUR Wired Controller (NASA)								104.00	
									System Price	1,164.00
AC035RXADKG/EU	1ph Inverter Heat Pump R32 Outdoor	3.5kW	4.0kW	6.1	4.0	13A	1/4", 3/8"	20m (15m)	723.00	
AC035RNLDKG/EU	Slim Ducted Unit	(0.85-4.3kW)	(1-5kW)	A++	A+				421.00	
MWR-WG00JN	LCD COLOUR Wired Controller (NASA)								104.00	
									System Price	1,248.00
AC052RXADKG/EU	1ph Inverter Heat Pump R32 Outdoor	5.0kW	6.0kW	6.1	3.9	20A	1/4", 1/2"	30m (20m)	853.00	
AC052RNLDKG/EU	Slim Ducted Unit	(1.2-6.5kW)	(1.1-7.2kW)	A++	A				451.00	
MWR-WG00JN	LCD COLOUR Wired Controller (NASA)								104.00	
									System Price	1,408.00
AC071RXADKG/EU	1ph Inverter Heat Pump R32 Outdoor	7.1kW	8.0kW	6.0	3.9	20A	1/4", 5/8"	50m (30m)	1,105.00	
AC071RNLDKG/EU	Slim Ducted Unit	(1.5-8.7kW)	(1.9-9kW)	A+	A				479.00	
MWR-WG00JN	LCD COLOUR Wired Controller (NASA)								104.00	
									System Price	1,688.00

Accessories for Slim Duct LIST PRICE €

MWR-WG00JN	LCD COLOUR Wired Controller (NASA)	104.00
MWR-SH11N	Touch Simplified Wired Remote Controller - WindFree™ (NASA)	101.00
MRW-TA	Remote Temperature Sensor	25.00
AR-EH03E	WindFree Wireless Remote controller (SPLIT/DVM)	39.00
MIM-H04EN	Wi-Fi Receiver 2.0 for NASA SPLIT/DVM IU	152.00
MRK-A10N	DUCT S & Slim Duct Wireless Signal Receiver Kit (requires AR-EH03E)	38.00
MDP-E075SEE3D	Drain Pump for Slim Ducted Unit - 2.6 & 3.5 kW models	89.00
MDP-G075SP	Drain Pump for DUCT S Ducted Unit (External Assembly) - 5.6 & 7.1 kW models	84.00

COMMERCIAL SPLIT SYSTEM

Air Conditioner

R410A



Large High Static Ducted

3 PHASE - R410A										
Model Reference	Description	Cool	Heat	EER	CoP	Max. Fuse	Pipe size Liq, Gas	Max. pipe length (height)	LIST PRICE €	
AC180JXAPNH/EU	3ph Inverter Heat Pump R410A Outdoor	18.0kW	20.0kW	3.3	3.6	20A/ph	3/8", 3/4"	75m (30m)	2,786.00	
AC180JNHPKH/EU	Large Ducted Unit	(6.0-20kW)	(4.8-22.5kW)						1,749.00	
MWR-WG00JN	LCD COLOUR Wired Controller (NASA)								104.00	
									System Price	4,639.00
AC200KXAPNH/EU	3ph Inverter Heat Pump R410A Outdoor	20.0kW	23.0kW	3.1	3.5	30A/ph	3/8", 3/4"	75m (30m)	2,857.00	
AC200KNHPKH/EU	Large Ducted Unit	(7.5-23kW)	(8.5-25kW)						1,830.00	
MWR-WG00JN	LCD COLOUR Wired Controller (NASA)								104.00	
									System Price	4,791.00
AC250KXAPNH/EU	3ph Inverter Heat Pump R410A Outdoor	25.0kW	27.0kW	2.6	3.2	30A/ph	3/8", 7/8"	75m (30m)	3,223.00	
AC250KNHPKH/EU	Large Ducted Unit	(6-28.5kW)	(10-32kW)						2,053.00	
MWR-WG00JN	LCD COLOUR Wired Controller (NASA)								104.00	
									System Price	5,380.00

whilst stocks last

Accessories for Large HSP Ducted LIST PRICE €

MWR-WG00JN	LCD COLOUR Wired Controller (NASA)	104.00
MRW-TA	Remote Temperature Sensor	25.00
MIM-H04EN	Wi-Fi Receiver 2.0 for NASA SPLI/DVM IU	152.00
MDP-G075SP	Drain Pump for DUCT S Ducted Unit (External Assembly)	84.00

COMMERCIAL SPLIT SYSTEM

Air Conditioner

R410A

75m pipe length



High Efficiency 4way Cassette

1 PHASE - R410A		Cool	Heat	SEER	SCoP	Max. Fuse	Pipe size Liq, Gas	Max. pipe length (height)	LIST PRICE €
Model Reference	Description								
AC071JXSCEH/EU	1ph Hi-Efficiency Inverter Heat Pump R410A	7.1kW	8.0kW	6.7	4.0	30A	3/8", 5/8"	75m (30m)	1,271.00
AC071JN4CEH/EU	High Efficiency 4-Way Cassette (840mm)	(1.7-8.5kW)	(3-11kW)	A++	A+				620.00
PC4NUSKEN	4-Way Cassette Fascia Panel Modern								167.00
MWR-WG00JN	LCD COLOUR Wired Controller (NASA)								104.00
System Price									2,162.00

AC100JXSCEH/EU	1ph Hi-Efficiency Inverter Heat Pump R410A	10.0kW	11.2kW	7.0	4.1	40A	3/8", 5/8"	75m (30m)	1,721.00
AC100JN4CEH/EU	High Efficiency 4-Way Cassette (840mm)	(2.2-12kW)	(3.3-17kW)	A++	A+				665.00
PC4NUSKEN	4-Way Cassette Fascia Panel Modern								167.00
MWR-WG00JN	LCD COLOUR Wired Controller (NASA)								104.00
System Price									2,657.00

3 PHASE - R410A		Cool	Heat	SEER	SCoP	Max. Fuse	Pipe size Liq, Gas	Max. pipe length (height)	LIST PRICE €
Model Reference	Description								
AC100JXSCGH/EU	3ph Hi-Efficiency Inverter Heat Pump R410A	10.0kW	11.2kW	7.0	4.1	16A/ph	3/8", 5/8"	75m (30m)	1,818.00
AC100JN4CEH/EU	High Efficiency 4-Way Cassette (840mm)	(2.2-12kW)	(3.3-17kW)	A++	A+				665.00
PC4NUSKEN	4-Way Cassette Fascia Panel Modern								167.00
MWR-WG00JN	LCD COLOUR Wired Controller (NASA)								104.00
System Price									2,754.00

		Cool	Heat	EER	CoP	Max. Fuse	Pipe size Liq, Gas	Max. pipe length (height)	LIST PRICE €
Model Reference	Description								
AC125JXSCGH/EU	3ph Hi-Efficiency Inverter Heat Pump R410A	12.5kW	14.0kW	3.2	3.7	16A/ph	3/8", 5/8"	75m (30m)	2,011.00
AC125JN4CEH/EU	High Efficiency 4-Way Cassette (840mm)	(2.2-14kW)	(3.3-19kW)						735.00
PC4NUSKEN	4-Way Cassette Fascia Panel Modern								167.00
MWR-WG00JN	LCD COLOUR Wired Controller (NASA)								104.00
System Price									3,017.00

Accessories for 4way Cassette		LIST PRICE €
MWR-WG00JN	LCD COLOUR Wired Controller (NASA)	104.00
PC4NUSKAN	4-Way Cassette Fascia Panel Waffle	167.00
PC4NBSKAN	4-Way Cassette Fascia Panel Waffle - BLACK	167.00
MSD-CAN1	S-Plasma Ion Kit for 4way & 360Cassette	76.00
MIM-H04EN	Wi-Fi Receiver 2.0 for NASA SPLI/DVM IU	152.00
AR-EH03E	Wireless Remote Controller	39.00



High Efficiency MSP Ducted

75m pipe length

1 PHASE - R410A		Cool	Heat	SEER	SCoP	Max. Fuse	Pipe size Liq, Gas	Max. pipe length (height)	LIST PRICE €
Model Reference	Description								
AC071JXSCEH/EU	1ph Hi-Efficiency Inverter Heat Pump R410A	7.1kW	8.0kW	6.1	4.0	30A	3/8", 5/8"	75m (30m)	1,271.00
AC071JNMCEH/EU	High Efficiency MSP Duct Indoor Unit	(1.7-8.5kW)	(3-11kW)	A++	A+				565.00
MWR-WG00JN	LCD COLOUR Wired Controller (NASA)								104.00
System Price									1,940.00

AC100JXSCEH/EU	1ph Hi-Efficiency Inverter Heat Pump R410A	10.0kW	11.2kW	6.7	4.1	40A	3/8", 5/8"	75m (30m)	1,721.00
AC100JNMCEH/EU	High Efficiency MSP Duct Indoor Unit	(2.2-12kW)	(3.3-17kW)	A++	A+				710.00
MWR-WG00JN	LCD COLOUR Wired Controller (NASA)								104.00
System Price									2,535.00

3 PHASE - R410A		Cool	Heat	SEER	SCoP	Max. Fuse	Pipe size Liq, Gas	Max. pipe length (height)	LIST PRICE €
Model Reference	Description								
AC100JXSCGH/EU	3ph Hi-Efficiency Inverter Heat Pump R410A	10.0kW	11.2kW	6.7	4.1	16A/ph	3/8", 5/8"	75m (30m)	1,818.00
AC100JNMCEH/EU	High Efficiency MSP Duct Indoor Unit	(2.2-12kW)	(3.3-17kW)	A++	A+				710.00
MWR-WG00JN	LCD COLOUR Wired Controller (NASA)								104.00
System Price									2,632.00

		Cool	Heat	EER	CoP	Max. Fuse	Pipe size Liq, Gas	Max. pipe length (height)	LIST PRICE €
Model Reference	Description								
AC125JXSCGH/EU	3ph Hi-Efficiency Inverter Heat Pump R410A	12.5kW	14.0kW	3.3	3.9	16A/ph	3/8", 5/8"	75m (30m)	2,011.00
AC125JNMCEH/EU	High Efficiency MSP Duct Indoor Unit	(2.2-14kW)	(3.3-19kW)						757.00
MWR-WG00JN	LCD COLOUR Wired Controller (NASA)								104.00
System Price									2,872.00

Accessories for MSP Duct		LIST PRICE €
MWR-WG00JN	LCD COLOUR Wired Controller (NASA)	104.00
MRW-TA	Remote Temperature Sensor	25.00
MSD-EAN1	S-Plasma Ion Healthy Air Provider for Ducted	76.00
MDP-G075SP	Drain Pump for DUCT S Ducted Unit (External Assembly)	84.00
MDP-G075SQ	Drain Pump for DUCT S Ducted Unit (Internal Assembly)	84.00

COMMERCIAL SPLIT SYSTEM

Air Conditioner

R410A



High Efficiency High Wall

75m pipe length

1 PHASE R410A		Cool	Heat	SEER	SCoP	Max. Fuse	Pipe size Liq, Gas	Max. pipe length (height)	LIST PRICE €
Model Reference	Description								
AC071JXSCEH/EU	1ph Hi-Efficiency Inverter Heat Pump R410A	7.1kW	8.0kW	6.5	4.0	30A	3/8", 5/8"	75m (30m)	1,271.00
AC071KNADEH/EU	High Efficiency Wall - Triangle	(1.7-8.5kW)	(3-11kW)	A++	A+				483.00
MWR-WG00JN	LCD COLOUR Wired Controller (NASA)								104.00
System Price									1,858.00

AC100JXSCEH/EU	1ph Hi-Efficiency Inverter Heat Pump R410A	10.0kW	11.2kW	6.0	4.0	40A	3/8", 5/8"	75m (30m)	1,721.00
AC100MNTCEH/EU	High Efficiency Wall - Rectangle	(2.2-12kW)	(3.3-17kW)	A+	A+				762.00
MWR-WG00JN	LCD COLOUR Wired Controller (NASA)								104.00
System Price									2,587.00

3 PHASE R410A		Cool	Heat	SEER	SCoP	Max. Fuse	Pipe size Liq, Gas	Max. pipe length (height)	LIST PRICE €
Model Reference	Description								
AC100JXSCGH/EU	3ph Hi-Efficiency Inverter Heat Pump R410A	10.0kW	11.2kW	6.0	4.0	16A/ph	3/8", 5/8"	75m (30m)	1,818.00
AC100MNTCEH/EU	High Efficiency Wall - Rectangle	(2.2-12kW)	(3.3-17kW)	A+	A+				762.00
MWR-WG00JN	LCD COLOUR Wired Controller (NASA)								104.00
System Price									2,684.00

Accessories for Wall LIST PRICE €

MWR-WG00JN	LCD COLOUR Wired Controller (NASA)	104.00
MWR-SH11N	Touch Simplified Wired Remote Controller (NASA)	101.00
MIM-H04EN	Wi-Fi Receiver 2.0 for NASA SPLI/DVM IU	152.00

COMMERCIAL SPLIT SYSTEM

Air Conditioner

R410A



PAC Floor Cabinet

1 PHASE R410A		Cool	Heat	SEER	SCoP	Max. Fuse	Pipe size Liq, Gas	Max. pipe length (height)	LIST PRICE €
Model Reference	Description								
AC100KXADEH/EU	1ph PAC Inverter Heat Pump R410A	10kW	11.2kW	5.8	4.1	25A	3/8", 5/8"	50m (30m)	1,426.00
AC100KNPDEH/EU	PAC Floor Cabinet	(3.5-12.3kW)	(4.2-14kW)	A+	A+				638.00
System Price									2,064.00

3 PHASE R410A		Cool	Heat	EER	CoP	Max. Fuse	Pipe size Liq, Gas	Max. pipe length (height)	LIST PRICE €
Model Reference	Description								
AC140KXADGH/EU	3ph PAC Inverter Heat Pump R410A	13.4kW	15.5kW	3.1	3.4	16A/ph	3/8", 5/8"	75m (30m)	1,864.00
AC140KNPDEH/EU	PAC Floor Cabinet	(4.2-16.7kW)	(4-20kW)						723.00
System Price									2,587.00

NOTE: No hard-wire control option for PAC as Control Panel is incorporated

COMMERCIAL SPLIT SYSTEM

Air Conditioner



Accessories & Controls

COMMERCIAL SPLIT SYSTEM ACCESSORIES & CONTROLS

Model Reference	Description	LIST PRICE €
REMOTE CONTROLS		
MWR-WG00JN	LCD COLOUR PREMIUM Wired Controller (NASA)	104.00
MWR-SH11N	Touch Simplified Wired Remote Controller - WindFree™ (NASA)	101.00
AR-KH03E	360 Wireless Remote controller (SPLIT/DVM)	39.00
AR-EH03E	WindFree & STANDARD Wireless Remote controller (SPLIT/DVM)	39.00
MIM-H04EN	Wi-Fi Receiver 2.0 for NASA SPLIT/DVM IU	152.00
MRK-A10N	DUCT S & Slim Duct Wireless Signal Receiver Kit (requires AR-EH03E)	38.00
CENTRAL CONTROLS & INTERFACES		
MCM-A300N	Touch Screen Controller NASA (Centralised management of up to 128 indoor units)	704.00
MCM-A202DN	Centralised On/Off Controller NASA (maximum of 16 Group controls (maximum of 256 indoor units))	110.00
MIM-B14	External Contact Interface Module (remote on/off, unit operation/error output)	23.00
MIM-B19N	MODBUS interface Module - 1 required per system	153.00
ALTERNATIVE FASCIA PANELS		
PC1NWFMAN	WindFree 1-Way Cassette Fascia Panel - Medium	162.00
PC1NWCMAN	WindFree 1-Way Cassette Fascia Panel - Medium - PURE Filter	496.00
PC4SUFMAN	WindFree Mini 4-Way Cassette Fascia Panel - 620x620	162.00
PC4NUFMAN	WindFree 4-Way Cassette Fascia Panel	167.00
PC4NUCEAN	WindFree 4-Way Cassette Fascia Panel - PURE Filter	594.00
PC4NUXMAN	WindFree 4-Way Cassette Fascia Panel - AutoLIFT	414.00
PC4NUDMAN	360 Cassette Fascia Panel Square WHITE	167.00
PC4NUNMAN	360 Cassette Fascia Panel Round WHITE	167.00
PC4NBDMAN	360 Cassette Fascia Panel - Square BLACK	167.00
PC4NBNMAN	360 Cassette Fascia Panel - Round BLACK	167.00
PC6EUCMAN	360 Cassette Fascia Panel Square - PURE Filter	528.00
PC6EUXMAN	360 Cassette Fascia Panel Square - AutoLIFT	496.00
PC4NUSKEN	4-Way Cassette Fascia Panel Modern	167.00
PC4NUSKAN	4-Way Cassette Fascia Panel Waffle	167.00
PC4NBSKAN	4-Way Cassette Fascia Panel Waffle - BLACK	167.00
ACCESSORIES		
MCR-SMC	Motion detect sensor for 4-way Cassette (WindFree) - for 950x950 panel	77.00
MCR-SMD	Motion detect sensor for 4-way Mini Cassette (WindFree) - for 620x620 panel	77.00
MCR-SME	Motion detect sensor for 360 Cassette - for SQUARE panel	77.00
MSD-CAN1	S-Plasma Ion Healthy Air Provider for 4-Way Cassette, 360 Cassette and Ceiling	76.00
MSD-EAN1	S-Plasma Ion Healthy Air Provider for Ducted (Duct S)	76.00
MRW-TA	Remote Temperature Sensor	25.00
MDP-G075SP	Drain Pump for DUCT S Ducted Unit (External Assembly)	84.00
MDP-G075SQ	Drain Pump for DUCT S Ducted Unit (Internal Assembly)	84.00
MDP-E075SEE3D	Drain Pump for Slim Ducted Unit - 2.6 & 3.5 kW models	89.00



COMMERCIAL MULTI SYSTEM

Air Conditioner

R32

DPM - Twin, Triple & Quad Split Systems 4 Way Mini Cassette WindFree™



DPM Systems must only be installed in the same room and with ONE remote controller

DPM - TWIN, TRIPLE & QUAD 4WAY MINI CASSETTE WindFree™ SYSTEMS R32

Reference	Indoor	Panel	Outdoor	Branch	Remote	LIST PRICE €
4way Mini W/F 7kW Twin	AC035RNNDKG/EU 329.00	x2 PC4SUFMAN 162.00	x2 AC071RXADKG/EU 1,105.00	MXJ-2D2509K 95.00	MWR-WG00JN 104.00	System Price 2,286.00
4way Mini W/F 10kW Twin	AC052RNNDKG/EU 387.00	x2 PC4SUFMAN 162.00	x2 AC100RXADKG/EU 1,496.00	MXJ-2D2509K 95.00	MWR-WG00JN 104.00	System Price 2,793.00
*3ph option available using AC100RXADNG/EU outdoor and additional cost of €83						
4way Mini W/F 10kW Triple	AC035RNNDKG/EU 329.00	x3 PC4SUFMAN 162.00	x3 AC100RXADKG/EU 1,496.00	MXJ-3D2509K 120.00	MWR-WG00JN 104.00	System Price 3,193.00
*3ph option available using AC100RXADNG/EU outdoor and additional cost of €83						
4way Mini W/F 12kW Triple	AC052RNNDKG/EU 387.00	x3 PC4SUFMAN 162.00	x3 AC120RXADKG/EU 1,678.00	MXJ-3D2509K 120.00	MWR-WG00JN 104.00	System Price 3,549.00
*3ph option available using AC120RXADNG/EU outdoor and additional cost of €70						
4way Mini W/F 12kW Quad	AC035RNNDKG/EU 329.00	x4 PC4SUFMAN 162.00	x4 AC120RXADKG/EU 1,678.00	MXJ-4D2509K 175.00	MWR-WG00JN 104.00	System Price 3,921.00
*3ph option available using AC120RXADNG/EU outdoor and additional cost of €70						
4way Mini W/F 14kW Twin	AC071RNNDKG/EU 483.00	x2 PC4SUFMAN 162.00	x2 AC140RXADKG/EU 1,892.00	MXJ-2D2509K 95.00	MWR-WG00JN 104.00	System Price 3,381.00
*3ph option available using AC140RXADNG/EU outdoor and additional cost of €65						
4way Mini W/F 14kW Triple	AC052RNNDKG/EU 387.00	x3 PC4SUFMAN 162.00	x3 AC140RXADKG/EU 1,892.00	MXJ-3D2509K 120.00	MWR-WG00JN 104.00	System Price 3,763.00
*3ph option available using AC140RXADNG/EU outdoor and additional cost of €65						
4way Mini W/F 14kW Quad	AC035RNNDKG/EU 329.00	x4 PC4SUFMAN 162.00	x4 AC140RXADKG/EU 1,892.00	MXJ-4D2509K 175.00	MWR-WG00JN 104.00	System Price 4,135.00
*3ph option available using AC140RXADNG/EU outdoor and additional cost of €65						

R410A 4 Way Mini Cassette WindFree™

DPM - TRIPLE & QUAD 4WAY MINI CASSETTE WindFree™ SYSTEMS R410A

LIST PRICE €

4way Mini W/F 20kW Triple	AC071RNNDKG/EU 483.00	x3 PC4SUFMAN 162.00	x3 AC200KXAPNH/EU 2,857.00	MXJ-3D2509K 120.00	MWR-WG00JN 104.00	System Price 5,016.00
4way Mini W/F 20kW Quad	AC052RNNDKG/EU 387.00	x4 PC4SUFMAN 162.00	x4 AC200KXAPNH/EU 2,857.00	MXJ-4D2509K 175.00	MWR-WG00JN 104.00	System Price 5,332.00
4way Mini W/F 25kW Quad	AC071RNNDKG/EU 483.00	x4 PC4SUFMAN 162.00	x4 AC250KXAPNH/EU 3,223.00	MXJ-4D2509K 175.00	MWR-WG00JN 104.00	System Price 6,082.00

COMMERCIAL MULTI SYSTEM

R32

DPM - Twin, Triple & Quad Split Systems 1 way WindFree™ Cassette

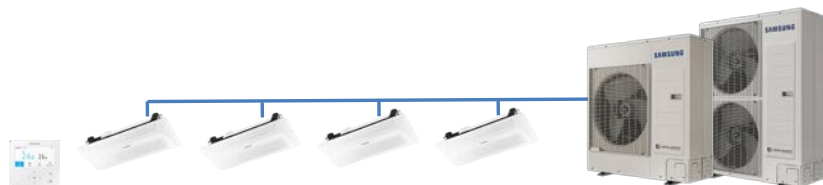

DPM Systems must only be installed in the same room and with ONE remote controller

DPM - TWIN, TRIPLE & QUAD 1WAY CASSETTE WindFree™ SYSTEMS R32

Reference	Indoor	Panel	Outdoor	Branch	Remote	LIST PRICE €
1way Cassette 7kW Twin	AC035RN1DKG/EU 457.00	x2 PC1NWFMAN 162.00	x2 AC071RXADKG/EU 1,105.00	MXJ-2D2509K 95.00	MWR-WG00JN 104.00	System Price 2,542.00
1way Cassette 10kW Triple	AC035RN1DKG/EU 457.00	x3 PC1NWFMAN 162.00	x3 AC100RXADKG/EU 1,496.00	MXJ-3D2509K 120.00	MWR-WG00JN 104.00	System Price 3,577.00
*3ph option available using AC100RXADNG/EU outdoor and additional cost of €83						
1way Cassette 12kW Quad	AC035RN1DKG/EU 457.00	x4 PC1NWFMAN 162.00	x4 AC120RXADKG/EU 1,678.00	MXJ-4D2509K 175.00	MWR-WG00JN 104.00	System Price 4,433.00
*3ph option available using AC120RXADNG/EU outdoor and additional cost of €70						
1way Cassette 14kW Quad	AC035RN1DKG/EU 457.00	x4 PC1NWFMAN 162.00	x4 AC140RXADKG/EU 1,892.00	MXJ-4D2509K 175.00	MWR-WG00JN 104.00	System Price 4,647.00
*3ph option available using AC140RXADNG/EU outdoor and additional cost of €65						

COMMERCIAL MULTI SYSTEM

R32

Air Conditioner

DPM - Twin, Triple & Quad Split Systems
4 Way Cassette WindFree™

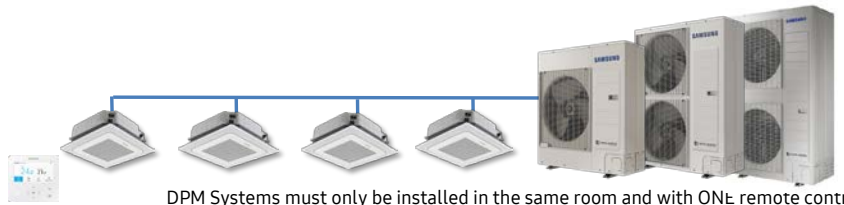

DPM Systems must only be installed in the same room and with ONE remote controller

DPM - TWIN, TRIPLE & QUAD 1WAY CASSETTE WindFree™ SYSTEMS R32

Reference	Indoor	Panel	Outdoor	Branch	Remote	LIST PRICE €
4way W/F 10kW Twin	AC052RN4DKG/EU 535.00	PC4NUFMAN 167.00	AC100RXADKG/EU 1,496.00	MXJ-2D2509K 95.00	MWR-WG00JN 104.00	System Price 3,099.00
*3ph option available using AC100RXADNG/EU outdoor and additional cost of €83						
4way W/F 12kW Triple	AC052RN4DKG/EU 535.00	PC4NUFMAN 167.00	AC120RXADKG/EU 1,678.00	MXJ-3D2509K 120.00	MWR-WG00JN 104.00	System Price 4,008.00
*3ph option available using AC120RXADNG/EU outdoor and additional cost of €70						
4way W/F 14kW Twin	AC071RN4DKG/EU 550.00	PC4NUFMAN 167.00	AC140RXADKG/EU 1,892.00	MXJ-2D2509K 95.00	MWR-WG00JN 104.00	System Price 3,525.00
*3ph option available using AC140RXADNG/EU outdoor and additional cost of €65						
4way W/F 14kW Triple	AC052RN4DKG/EU 535.00	PC4NUFMAN 167.00	AC140RXADKG/EU 1,892.00	MXJ-3D2509K 120.00	MWR-WG00JN 104.00	System Price 4,222.00
*3ph option available using AC140RXADNG/EU outdoor and additional cost of €65						

R410A 4 Way Cassette WindFree™

DPM - TWIN, TRIPLE & QUAD 4WAY MINI CASSETTE WindFree™ SYSTEMS R410A

LIST PRICE €

Reference	Indoor	Panel	Outdoor	Branch	Remote	LIST PRICE €
4way Cassette 20kW Twin	AC100RN4DKG/EU 589.00	PC4NUFMAN 167.00	AC200KXAPNH/EU 2,857.00	MXJ-2D2509K 95.00	MWR-WG00JN 104.00	System Price 4,568.00
4way Cassette 20kW Triple	AC071RN4DKG/EU 550.00	PC4NUFMAN 167.00	AC200KXAPNH/EU 2,857.00	MXJ-3D2509K 120.00	MWR-WG00JN 104.00	System Price 5,232.00
4way Cassette 20kW Quad	AC052RN4DKG/EU 535.00	PC4NUSKEN 167.00	AC200KXAPNH/EU 2,857.00	MXJ-4D2509K 175.00	MWR-WG00JN 104.00	System Price 5,944.00
4way Cassette 25kW Twin	AC120RN4DKG/EU 651.00	PC4NUFMAN 167.00	AC250KXAPNH/EU 3,223.00	MXJ-2D2509K 95.00	MWR-WG00JN 104.00	System Price 5,058.00
4way Cassette 25kW Quad	AC071RN4DKG/EU 550.00	PC4NUFMAN 167.00	AC250KXAPNH/EU 3,223.00	MXJ-4D2509K 175.00	MWR-WG00JN 104.00	System Price 6,370.00

COMMERCIAL MULTI SYSTEM

R32

Air Conditioner

DPM - Twin, Triple & Quad Split Systems
360 Cassette

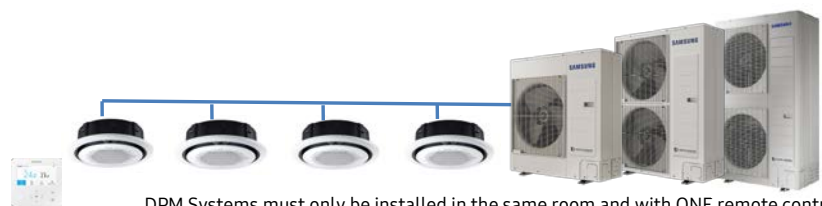

DPM Systems must only be installed in the same room and with ONE remote controller

DPM - TWIN, TRIPLE & QUAD 360 CASSETTE SYSTEMS R32

Reference	Indoor	Panel	Outdoor	Branch	Remote	LIST PRICE €
360 Cassette 14kW Twin	AC071RN4PKG/EU 747.00	PC4NUNMAN 167.00	AC140RXADKG/EU 1,892.00	MXJ-2D2509K 95.00	MWR-WG00JN 104.00	System Price 3,919.00
*3ph option available using AC140RXADNG/EU outdoor and additional cost of €65						

R410A 360 Cassette

DPM - TWIN, TRIPLE & QUAD 360 CASSETTE SYSTEMS R410A

LIST PRICE €

Reference	Indoor	Panel	Outdoor	Branch	Remote	LIST PRICE €
360 Cassette 20kW Twin	AC100RN4PKG/EU 794.00	PC4NUNMAN 167.00	AC200KXAPNH/EU 2,857.00	MXJ-2D2509K 95.00	MWR-WG00JN 104.00	System Price 4,978.00
360 Cassette 20kW Triple	AC071RN4PKG/EU 747.00	PC4NUNMAN 167.00	AC200KXAPNH/EU 2,857.00	MXJ-3D2509K 120.00	MWR-WG00JN 104.00	System Price 5,823.00
360 Cassette 25kW Twin	AC120RN4PKG/EU 882.00	PC4NUNMAN 167.00	AC250KXAPNH/EU 3,223.00	MXJ-2D2509K 95.00	MWR-WG00JN 104.00	System Price 5,520.00
360 Cassette 25kW Quad	AC071RN4PKG/EU 747.00	PC4NUNMAN 167.00	AC250KXAPNH/EU 3,223.00	MXJ-4D2509K 175.00	MWR-WG00JN 104.00	System Price 7,158.00

COMMERCIAL MULTI SYSTEM

Air Conditioner

R32

19

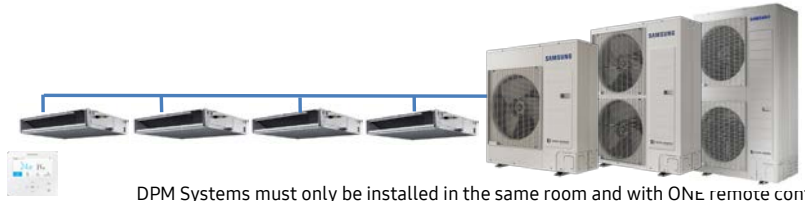

DPM - Twin, Triple & Quad Split Systems Slim Ducted

DPM Systems must only be installed in the same room and with ONE remote controller

DPM - TWIN, TRIPLE & QUAD SLIM DUCTED SYSTEMS R32

Reference	Indoor	Outdoor	Branch	Remote	LIST PRICE €
Slim Ducted 7kW Twin	AC035RNLDKG/EU 421.00 x 2	AC071RXADKG/EU 1,105.00	MXJ-2D2509K 95.00	MWR-WG00JN 104.00	System Price 2,146.00
Slim Ducted 10kW Twin	AC052RNLDKG/EU 451.00 x 2	AC100RXADKG/EU 1,496.00	MXJ-2D2509K 95.00	MWR-WG00JN 104.00	System Price 2,597.00
*3ph option available using AC100RXADNG/EU outdoor and additional cost of €83					
Slim Ducted 10kW Triple	AC035RNLDKG/EU 421.00 x 3	AC100RXADKG/EU 1,496.00	MXJ-3D2509K 120.00	MWR-WG00JN 104.00	System Price 2,983.00
*3ph option available using AC100RXADNG/EU outdoor and additional cost of €83					
Slim Ducted 12kW Triple	AC052RNLDKG/EU 451.00 x 3	AC120RXADKG/EU 1,678.00	MXJ-3D2509K 120.00	MWR-WG00JN 104.00	System Price 3,255.00
*3ph option available using AC120RXADNG/EU outdoor and additional cost of €70					
Slim Ducted 12kW Quad	AC035RNLDKG/EU 421.00 x 4	AC120RXADKG/EU 1,678.00	MXJ-4D2509K 175.00	MWR-WG00JN 104.00	System Price 3,641.00
*3ph option available using AC120RXADNG/EU outdoor and additional cost of €70					
Slim Ducted 14kW Twin	AC071RNLDKG/EU 479.00 x 2	AC140RXADKG/EU 1,892.00	MXJ-2D2509K 95.00	MWR-WG00JN 104.00	System Price 3,049.00
*3ph option available using AC140RXADNG/EU outdoor and additional cost of €65					
Slim Ducted 14kW Triple	AC052RNLDKG/EU 451.00 x 3	AC140RXADKG/EU 1,892.00	MXJ-3D2509K 120.00	MWR-WG00JN 104.00	System Price 3,469.00
*3ph option available using AC140RXADNG/EU outdoor and additional cost of €65					
Slim Ducted 14kW Quad	AC035RNLDKG/EU 421.00 x 4	AC140RXADKG/EU 1,892.00	MXJ-4D2509K 175.00	MWR-WG00JN 104.00	System Price 3,855.00
*3ph option available using AC140RXADNG/EU outdoor and additional cost of €65					

R410A Slim Ducted

DPM - TWIN, TRIPLE & QUAD DUCTED SYSTEMS R410A

LIST PRICE €

Slim Ducted 20kW Triple	AC071RNLDKG/EU 479.00 x 3	AC200KXAPNH/EU 2,857.00	MXJ-3D2509K 120.00	MWR-WG00JN 104.00	System Price 4,518.00
Slim Ducted 20kW Quad	AC052RNLDKG/EU 451.00 x 4	AC200KXAPNH/EU 2,857.00	MXJ-4D2509K 175.00	MWR-WG00JN 104.00	System Price 4,940.00
Slim Ducted 25kW Quad	AC071RNLDKG/EU 479.00 x 4	AC250KXAPNH/EU 3,223.00	MXJ-4D2509K 175.00	MWR-WG00JN 104.00	System Price 5,418.00

COMMERCIAL MULTI SYSTEM

Air Conditioner

R32

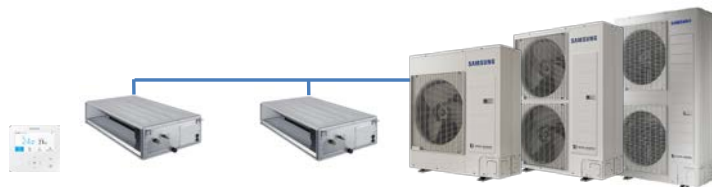

DPM - Twin, Triple & Quad Split Systems

MSP Duct S

DPM Systems must only be installed in the same room and with ONE remote controller

DPM - TWIN, TRIPLE & QUAD DUCT S SYSTEMS R32

Reference	Indoor		Outdoor	Branch	Remote	LIST PRICE €
MSP Duct S 7kW Twin	AC035RNMDKG/EU 430.00	x 2	AC071RXADKG/EU 1,105.00	MXJ-2D2509K 95.00	MWR-WG00JN 104.00	System Price 2,164.00
MSP Duct S 10kW Twin	AC052RNMDKG/EU 441.00	x 2	AC100RXADKG/EU 1,496.00	MXJ-2D2509K 95.00	MWR-WG00JN 104.00	System Price 2,577.00
<small>*3ph option available using AC100RXADNG/EU outdoor and additional cost of €83</small>						
MSP Duct S 10kW Triple	AC035RNMDKG/EU 430.00	x 3	AC100RXADKG/EU 1,496.00	MXJ-3D2509K 120.00	MWR-WG00JN 104.00	System Price 3,010.00
<small>*3ph option available using AC100RXADNG/EU outdoor and additional cost of €83</small>						
MSP Duct S 12kW Triple	AC052RNMDKG/EU 441.00	x 3	AC120RXADKG/EU 1,678.00	MXJ-3D2509K 120.00	MWR-WG00JN 104.00	System Price 3,225.00
<small>*3ph option available using AC120RXADNG/EU outdoor and additional cost of €70</small>						
MSP Duct S 12kW Quad	AC035RNMDKG/EU 430.00	x 4	AC120RXADKG/EU 1,678.00	MXJ-4D2509K 175.00	MWR-WG00JN 104.00	System Price 3,677.00
<small>*3ph option available using AC120RXADNG/EU outdoor and additional cost of €70</small>						
MSP Duct S 14kW Twin	AC071RNMDKG/EU 490.00	x 2	AC140RXADKG/EU 1,892.00	MXJ-2D2509K 95.00	MWR-WG00JN 104.00	System Price 3,071.00
<small>*3ph option available using AC140RXADNG/EU outdoor and additional cost of €65</small>						
MSP Duct S 14kW Triple	AC052RNMDKG/EU 441.00	x 3	AC140RXADKG/EU 1,892.00	MXJ-3D2509K 120.00	MWR-WG00JN 104.00	System Price 3,439.00
<small>*3ph option available using AC140RXADNG/EU outdoor and additional cost of €65</small>						
MSP Duct S 14kW Quad	AC035RNMDKG/EU 430.00	x 4	AC140RXADKG/EU 1,892.00	MXJ-4D2509K 175.00	MWR-WG00JN 104.00	System Price 3,891.00
<small>*3ph option available using AC140RXADNG/EU outdoor and additional cost of €65</small>						

R410A MSP Duct S

DPM - TWIN, TRIPLE & QUAD DUCT S SYSTEMS R410A

LIST PRICE €

MSP Duct S 20kW Twin	AC100RNMDKG/EU 617.00	x 2	AC200KXAPNH/EU 2,857.00	MXJ-2D2509K 95.00	MWR-WG00JN 104.00	System Price 4,290.00
MSP Duct S 20kW Triple	AC071RNMDKG/EU 490.00	x 3	AC200KXAPNH/EU 2,857.00	MXJ-3D2509K 120.00	MWR-WG00JN 104.00	System Price 4,551.00
MSP Duct S 20kW Quad	AC052RNMDKG/EU 441.00	x 4	AC200KXAPNH/EU 2,857.00	MXJ-4D2509K 175.00	MWR-WG00JN 104.00	System Price 4,900.00
MSP Duct S 25kW Twin	AC120RNMDKG/EU 659.00	x 2	AC250KXAPNH/EU 3,223.00	MXJ-2D2509K 95.00	MWR-WG00JN 104.00	System Price 4,740.00
MSP Duct S 25kW Quad	AC071RNMDKG/EU 490.00	x 4	AC250KXAPNH/EU 3,223.00	MXJ-4D2509K 175.00	MWR-WG00JN 104.00	System Price 5,462.00

COMMERCIAL MULTI SYSTEM

Air Conditioner

R32

21

DPM - Twin, Triple & Quad Split Systems Wall WindFree™

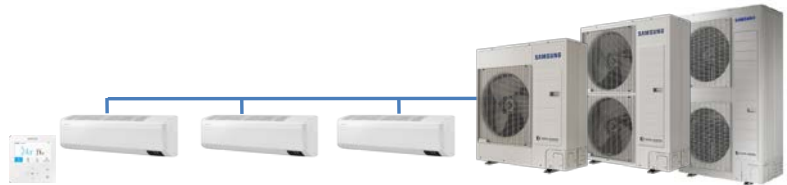

DPM Systems must only be installed in the same room and with ONE remote controller

DPM - TWIN, TRIPLE & QUAD WALL SYSTEMS R32

Reference	Indoor	Outdoor	Branch	Remote	LIST PRICE €
Wall 7kW Twin	AC035TNXDKG/EU 301.00 x 2	AC071RXADKG/EU 1,105.00	MXJ-2D2509K 95.00	MWR-WG00JN 104.00	System Price 1,906.00
Wall 10kW Twin	AC052TNXDKG/EU 387.00 x 2	AC100RXADKG/EU 1,496.00	MXJ-2D2509K 95.00	MWR-WG00JN 104.00	System Price 2,469.00
<small>*3ph option available using AC100RXADNG/EU outdoor and additional cost of €83</small>					
Wall 10kW Triple	AC035TNXDKG/EU 301.00 x 3	AC100RXADKG/EU 1,496.00	MXJ-3D2509K 120.00	MWR-WG00JN 104.00	System Price 2,623.00
<small>*3ph option available using AC100RXADNG/EU outdoor and additional cost of €83</small>					
Wall 12kW Triple	AC052TNXDKG/EU 387.00 x 3	AC120RXADKG/EU 1,678.00	MXJ-3D2509K 120.00	MWR-WG00JN 104.00	System Price 3,063.00
<small>*3ph option available using AC120RXADNG/EU outdoor and additional cost of €70</small>					
Wall 12kW Quad	AC035TNXDKG/EU 301.00 x 4	AC120RXADKG/EU 1,678.00	MXJ-4D2509K 175.00	MWR-WG00JN 104.00	System Price 3,161.00
<small>*3ph option available using AC120RXADNG/EU outdoor and additional cost of €70</small>					
Wall 14kW Twin	AC071TNXDKG/EU 433.00 x 2	AC140RXADKG/EU 1,892.00	MXJ-2D2509K 95.00	MWR-WG00JN 104.00	System Price 2,957.00
<small>*3ph option available using AC140RXADNG/EU outdoor and additional cost of €65</small>					
Wall 14kW Triple	AC052TNXDKG/EU 387.00 x 3	AC140RXADKG/EU 1,892.00	MXJ-3D2509K 120.00	MWR-WG00JN 104.00	System Price 3,277.00
<small>*3ph option available using AC140RXADNG/EU outdoor and additional cost of €65</small>					
Wall 14kW Quad	AC035TNXDKG/EU 301.00 x 4	AC140RXADKG/EU 1,892.00	MXJ-4D2509K 175.00	MWR-WG00JN 104.00	System Price 3,375.00
<small>*3ph option available using AC140RXADNG/EU outdoor and additional cost of €65</small>					

R410A Wall WindFree™

DPM - TWIN, TRIPLE & QUAD WALL SYSTEMS R410A

LIST PRICE €

Wall 20kW Triple	AC071TNXDKG/EU 433.00 x 3	AC200KXAPNH/EU 2,857.00	MXJ-3D2509K 120.00	MWR-WG00JN 104.00	System Price 4,380.00
Wall 20kW Quad	AC052TNXDKG/EU 387.00 x 4	AC200KXAPNH/EU 2,857.00	MXJ-4D2509K 175.00	MWR-WG00JN 104.00	System Price 4,684.00
Wall 25kW Quad	AC071TNXDKG/EU 433.00 x 4	AC250KXAPNH/EU 3,223.00	MXJ-4D2509K 175.00	MWR-WG00JN 104.00	System Price 5,234.00
Wall Large 20kW Twin	AC100RNTDKG/EU 662.00 x 2	AC200KXAPNH/EU 2,857.00	MXJ-2D2509K 95.00	MWR-WG00JN 104.00	System Price 4,380.00



COMMERCIAL MULTI SYSTEM

Air Conditioner

R32

DPM - Twin, Triple & Quad Split Systems
Ceiling

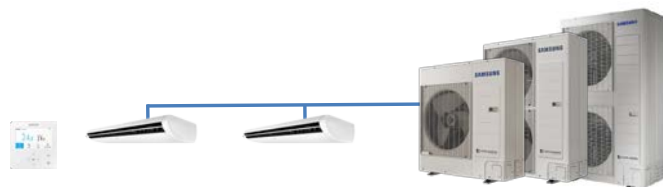

DPM Systems must only be installed in the same room and with ONE remote controller

DPM - TWIN, TRIPLE & QUAD CEILING SYSTEMS R32

Reference	Indoor	Outdoor	Branch	Remote	LIST PRICE €
Ceiling 10kW Twin	AC052RNCDKG/EU 462.00 x 2	AC100RXADKG/EU 1,496.00	MXJ-2D2509K 95.00	MWR-WG00JN 104.00	System Price 2,619.00
*3ph option available using AC100RXADNG/EU outdoor and additional cost of €83					
Ceiling 12kW Triple	AC052RNCDKG/EU 462.00 x 3	AC120RXADKG/EU 1,678.00	MXJ-3D2509K 120.00	MWR-WG00JN 104.00	System Price 3,288.00
*3ph option available using AC120RXADNG/EU outdoor and additional cost of €70					
Ceiling 14kW Twin	AC071RNCDKG/EU 470.00 x 2	AC140RXADKG/EU 1,892.00	MXJ-2D2509K 95.00	MWR-WG00JN 104.00	System Price 3,031.00
*3ph option available using AC140RXADNG/EU outdoor and additional cost of €65					
Ceiling 14kW Triple	AC052RNCDKG/EU 462.00 x 3	AC140RXADKG/EU 1,892.00	MXJ-3D2509K 120.00	MWR-WG00JN 104.00	System Price 3,502.00
*3ph option available using AC140RXADNG/EU outdoor and additional cost of €65					

R410A

Ceiling

DPM - TWIN, TRIPLE & QUAD CEILING SYSTEMS R410A

LIST PRICE €

Reference	Indoor	Outdoor	Branch	Remote	LIST PRICE €
Ceiling 20kW Twin	AC100RNCDKG/EU 1,054.00 x 2	AC200KXAPNH/EU 2,857.00	MXJ-2D2509K 95.00	MWR-WG00JN 104.00	System Price 5,164.00
Ceiling 20kW Triple	AC071RNCDKG/EU 470.00 x 3	AC200KXAPNH/EU 2,857.00	MXJ-3D2509K 120.00	MWR-WG00JN 104.00	System Price 4,491.00
Ceiling 20kW Quad	AC052RNCDKG/EU 462.00 x 4	AC200KXAPNH/EU 2,857.00	MXJ-4D2509K 175.00	MWR-WG00JN 104.00	System Price 4,984.00
Ceiling 25kW Twin	AC120RNCDKG/EU 1,162.00 x 2	AC250KXAPNH/EU 3,223.00	MXJ-2D2509K 95.00	MWR-WG00JN 104.00	System Price 5,746.00
Ceiling 25kW Quad	AC071RNCDKG/EU 470.00 x 4	AC250KXAPNH/EU 3,223.00	MXJ-4D2509K 175.00	MWR-WG00JN 104.00	System Price 5,382.00

COMMERCIAL MULTI SYSTEM

Air Conditioner

R410A

DPM - Twin, Triple & Quad Split Systems
Floor Console



DPM Systems must only be installed in the same room and with ONE remote controller

DPM - TWIN, TRIPLE & QUAD FLOOR SYSTEMS R32

Reference	Indoor	Outdoor	Branch	Remote	LIST PRICE €
Floor Console 7kW Twin	AC035MNJDKH/EU 436.00 x 2	AC071MXADKH/EU 1,073.00	MXJ-2D2509K 95.00	MWR-WG00JN 104.00	System Price 2,144.00
Floor Console 10kW Twin	AC052MNJDKH/EU 505.00 x 2	AC100MXADKH/EU 1,452.00	MXJ-2D2509K 95.00	MWR-WG00JN 104.00	System Price 2,661.00
*3ph option available using AC100RXADNG/EU outdoor and additional cost of €83					
Floor Console 10kW Triple	AC035MNJDKH/EU 436.00 x 3	AC100MXADKH/EU 1,452.00	MXJ-3D2509K 120.00	MWR-WG00JN 104.00	System Price 2,984.00
*3ph option available using AC100RXADNG/EU outdoor and additional cost of €83					
Floor Console 12kW Triple	AC052MNJDKH/EU 505.00 x 3	AC120MXADKH/EU 1,629.00	MXJ-3D2509K 120.00	MWR-WG00JN 104.00	System Price 3,368.00
*3ph option available using AC120RXADNG/EU outdoor and additional cost of €70					
Floor Console 12kW Quad	AC035MNJDKH/EU 436.00 x 4	AC120MXADKH/EU 1,629.00	MXJ-4D2509K 175.00	MWR-WG00JN 104.00	System Price 3,652.00
*3ph option available using AC120RXADNG/EU outdoor and additional cost of €70					
Floor Console 14kW Triple	AC052MNJDKH/EU 505.00 x 3	AC140MXADKH/EU 1,837.00	MXJ-3D2509K 120.00	MWR-WG00JN 104.00	System Price 3,576.00
*3ph option available using AC140RXADNG/EU outdoor and additional cost of €65					
Floor Console 14kW Quad	AC035MNJDKH/EU 436.00 x 4	AC140MXADKH/EU 1,837.00	MXJ-4D2509K 175.00	MWR-WG00JN 104.00	System Price 3,860.00
*3ph option available using AC140RXADNG/EU outdoor and additional cost of €65					
Floor Console 20kW Quad	AC052RNJDKG/EU 520.00 x 4	AC200KXAPNH/EU 2,857.00	MXJ-4D2509K 175.00	MWR-WG00JN 104.00	System Price 5,216.00

NOTE: Console DPM systems only available using R410A refrigerant, due to BS EN 378 regulations

COMMERCIAL MULTI SYSTEM

Air Conditioner

DPM - Twin, Triple & Quad Split Systems



DPM Limitations

	R32		R410A
	7,10 & 12kW OU	14kW OU	20 & 25kW OU
Total Pipe length (all lengths combined)	50m	75m	75m
Max. Main pipe length (L ₁)	30m	50m	75m
Max. Leg length after branch pipe		15m	
Max. difference between leg length (e.g. L ₂ -L ₃)		5m	
Max. distance between Indoor units (D)		10m	
Max. height between Indoors & outdoor (h ₁)		30m	
Max. height difference between Indoors (h ₂)		0.5m	

* Indoor units should be installed in one area which is not divided by a wall & controlled via 1 remote

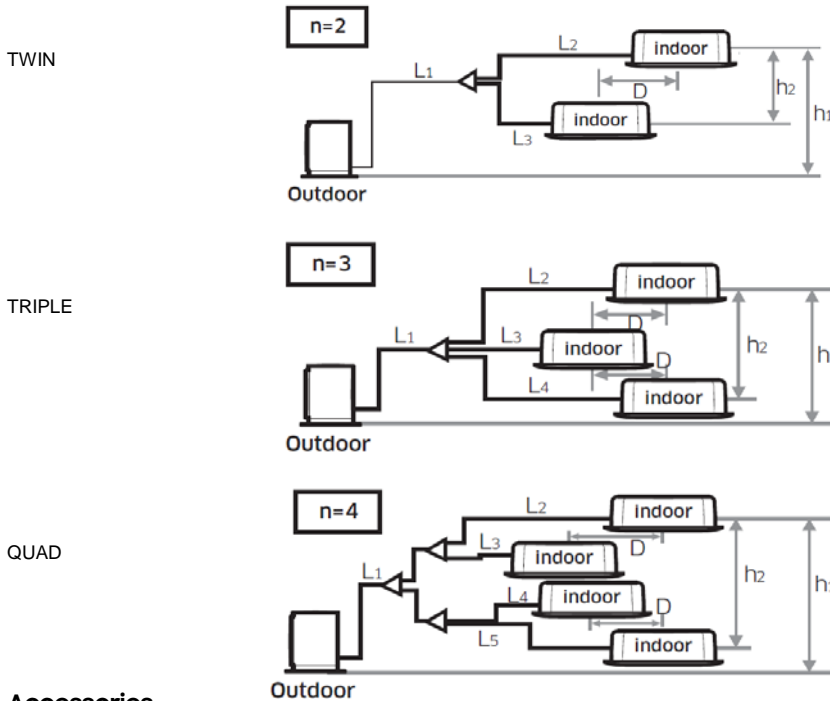

Accessories

DPM ACCESSORIES		LIST PRICE €
Model Reference	Description	
MXJ-2D2509K	2-Way Branch Pipe Kit for DPM TWIN systems	95.00
MXJ-3D2509K	3-Way Branch Pipe Kit for DPM TRIPLE systems	120.00
MXJ-4D2509K	4-Way Branch Pipe Kit for DPM QUAD systems	175.00
MWR-WG00JN	LCD COLOUR Wired Controller (NASA)	104.00
MCM-A300N	Touch Screen Controller NASA (Centralised management of up to 128 indoor units)	704.00
MIM-B14	External Contact Interface Module (remote on/off, unit operation/error output)	23.00
MIM-B19N	MODBUS interface Module - 1 required per system	153.00
PC1NWFMAN	WindFree 1-Way Cassette Fascia Panel - Medium	162.00
PC1NWCMAN	WindFree 1-Way Cassette Fascia Panel - Medium - PURE Filter	496.00
PC4SUFMAN	WindFree Mini 4-Way Cassette Fascia Panel - 620x620	162.00
PC4NUFMAN	WindFree 4-Way Cassette Fascia Panel	167.00
PC4NUCEAN	WindFree 4-Way Cassette Fascia Panel - PURE Filter	594.00
PC4NUXMAN	WindFree 4-Way Cassette Fascia Panel - AutoLIFT	414.00
PC4NUDMAN	360 Cassette Fascia Panel Square	167.00
PC4NUNMAN	360 Cassette Fascia Panel Round	167.00
PC4NBDMAN	360 Cassette Fascia Panel - Square BLACK	167.00
PC4NBNMAN	360 Cassette Fascia Panel - Round BLACK	167.00
PC6EUCMAN	360 Cassette Fascia Panel Square - PURE Filter	528.00
PC6EUXMAN	360 Cassette Fascia Panel Square - AutoLIFT	496.00
MSD-CAN1	S-Plasma Ion Healthy Air Provider for 4-Way Cassette, 360 Cassette and Ceiling	76.00
MSD-EAN1	S-Plasma Ion Healthy Air Provider for Ducted (Duct S)	76.00
MDP-G075SP	Drain Pump for DUCT S Ducted Unit (External Assembly)	84.00
MDP-G075SQ	Drain Pump for DUCT S Ducted Unit (Internal Assembly)	84.00
MDP-E0755EE3D	Drain Pump for Slim Ducted Unit - 2.6 & 3.5kW models (use MDP-G075SP for other Slim Ducted models)	89.00

Free Joint Multi



FJM - Outdoor Units

OUTDOOR UNITS ~ 1 PHASE R32							LIST PRICE €
Model Reference	Type	Cool	Heat	Max. Fuse	Total Pipe length	Description	
(*max. pipe length per leg)							
AJ040TXJ2KG/EU	2 Port	4.0kW	4.4kW	10A	30m (*20m)	Inverter Heat Pump R32 1 Phase	951.00
AJ050TXJ2KG/EU	2 Port	5.0kW	5.7kW	13A	30m (*20m)	Inverter Heat Pump R32 1 Phase	1,045.00
AJ052TXJ3KG/EU	3 Port	5.2kW	6.3kW	13A	50m (*25m)	Inverter Heat Pump R32 1 Phase	1,478.00
AJ068TXJ3KG/EU	3 Port	6.8kW	8.0kW	20A	50m (*25m)	Inverter Heat Pump R32 1 Phase	1,578.00
AJ080TXJ4KG/EU	4 Port	8.0kW	9.3kW	20A	70m (*25m)	Inverter Heat Pump R32 1 Phase	1,846.00
AJ100TXJ5KG/EU	5 Port	10.0kW	12.0kW	25A	75m (*25m)	Inverter Heat Pump R32 1 Phase	2,267.00

NB: The R32 Console unit may not adhere to BSEN378 regulations when applied to outdoor units >6kW - please contact Samsung for more information

FJM - Indoor Units

MULTI WALL UNITS			Pipe size		LIST PRICE €
Model Reference	Cool	Heat	Liq, Gas	Description	

LUZON - Easy Filter Plus

AR07TXHZAWKNEU	2.0kW	2.2kW	1/4", 3/8"	Luzon High Wall Mounted Unit	217.00
AR09TXHZAWKNEU	2.5kW	3.2kW	1/4", 3/8"	Luzon High Wall Mounted Unit	235.00
AR12TXHZAWKNEU	3.5kW	4.0kW	1/4", 3/8"	Luzon High Wall Mounted Unit	260.00
AR18TXHZAWKNEU	5.0kW	6.0kW	1/4", 1/2"	Luzon High Wall Mounted Unit	401.00
AR24TXHZAWKNEU	6.5kW	7.4kW	1/4", 5/8"	Luzon High Wall Mounted Unit	530.00



CEBU - Wi-Fi & Easy Filter Plus

AR07TXFYAWKNEU	2.0kW	2.2kW	1/4", 3/8"	Cebu High Wall Mounted Unit	238.00
AR09TXFYAWKNEU	2.5kW	3.2kW	1/4", 3/8"	Cebu High Wall Mounted Unit	258.00
AR12TXFYAWKNEU	3.5kW	4.0kW	1/4", 3/8"	Cebu High Wall Mounted Unit	287.00
AR18TXFYAWKNEU	5.0kW	6.0kW	1/4", 1/2"	Cebu High Wall Mounted Unit	441.00
AR24TXFYAWKNEU	6.5kW	7.4kW	1/4", 5/8"	Cebu High Wall Mounted Unit	583.00



COMFORT WindFree™ Wi-Fi & Easy Filter Plus

AR07TXFCAWKNEU	2.0kW	2.2kW	1/4", 3/8"	Comfort WindFree High Wall Mounted Unit	297.00
AR09TXFCAWKNEU	2.5kW	3.2kW	1/4", 3/8"	Comfort WindFree High Wall Mounted Unit	327.00
AR12TXFCAWKNEU	3.5kW	4.0kW	1/4", 3/8"	Comfort WindFree High Wall Mounted Unit	353.00
AR18TXFCAWKNEU	5.0kW	6.0kW	1/4", 1/2"	Comfort WindFree High Wall Mounted Unit	475.00
AR24TXFCAWKNEU	6.5kW	7.4kW	1/4", 5/8"	Comfort WindFree High Wall Mounted Unit	647.00



AVANT WindFree™ Wi-Fi & Tri-Care Filter

AR07TXEAAWKNEU	2.0kW	2.2kW	1/4", 3/8"	Avant WindFree High Wall Mounted Unit	342.00
AR09TXEAAWKNEU	2.5kW	3.2kW	1/4", 3/8"	Avant WindFree High Wall Mounted Unit	377.00
AR12TXEAAWKNEU	3.5kW	4.0kW	1/4", 3/8"	Avant WindFree High Wall Mounted Unit	413.00
AR18TXEAAWKNEU	5.0kW	6.0kW	1/4", 1/2"	Avant WindFree High Wall Mounted Unit	568.00
AR24TXEAAWKNEU	6.5kW	7.4kW	1/4", 5/8"	Avant WindFree High Wall Mounted Unit	755.00



ELITE WindFree™ Wi-Fi, Tri-Care Filter & Motion Detection Sensor

AR07TXCAAWKNEU	2.0kW	2.2kW	1/4", 3/8"	Elite WindFree High Wall Mounted Unit	377.00
AR09TXCAAWKNEU	2.5kW	3.2kW	1/4", 3/8"	Elite WindFree High Wall Mounted Unit	435.00
AR12TXCAAWKNEU	3.5kW	4.0kW	1/4", 3/8"	Elite WindFree High Wall Mounted Unit	474.00



PLEASE NOTE: Please see the allowed combination table in FJM TDB, for compatibility confirmation between outdoor/indoor models
Previous FJM version indoor/outdoor units are NOT compatible with NASA protocol models listed on this page

*Above Wall Mounted indoor units require MIM-A00N interface for connection to wired controller

Free Joint Multi

Mini Multi Split Systems



FJM - Indoor Units

MULTI CONSOLE FLOOR, DUCTED & CASSETTE UNITS				Pipe size		Description	LIST PRICE €
Model Reference	Cool	Heat	Liq, Gas				

Floor



AJ026TNJDKG/EU	2.6kW	2.9kW	1/4", 3/8"	Console Floor Standing Unit	407.00
AJ035TNJDKG/EU	3.5kW	3.8kW	1/4", 3/8"	Console Floor Standing Unit	456.00
AJ052TNJDKG/EU	5.2kW	5.6kW	1/4", 1/2"	Console Floor Standing Unit	532.00

NB: The R32 Console unit may not adhere to BSEN378 regulations when applied to outdoor units >6kW - please contact Samsung for more information

Ducted



AJ026TNLDEG/EU	2.6kW	2.9kW	1/4", 3/8"	Slimline Ducted Unit	465.00
AJ035TNLDEG/EU	3.5kW	3.8kW	1/4", 3/8"	Slimline Ducted Unit	502.00
AJ052TNMDEG/EU	5.2kW	6.0kW	1/4", 1/2"	MSP Ducted Unit	581.00

AJ026TNLPEG/EU	2.6kW	2.9kW	1/4", 3/8"	Slimline Ducted Unit - With PUMP	496.00
AJ035TNLPEG/EU	3.5kW	3.8kW	1/4", 3/8"	Slimline Ducted Unit - With PUMP	534.00

WindFree™ 4way Mini cassette



AJ016TNNDKG/EU	1.6kW	1.8kW	1/4", 3/8"	WindFree 4-Way Mini Cassette	379.00
AJ020TNNDKG/EU	2.0kW	2.2kW	1/4", 3/8"	WindFree 4-Way Mini Cassette	400.00
AJ026TNNDKG/EU	2.5kW	3.2kW	1/4", 3/8"	WindFree 4-Way Mini Cassette	420.00
AJ035TNNDKG/EU	3.5kW	3.8kW	1/4", 3/8"	WindFree 4-Way Mini Cassette	459.00
AJ052TNNDKG/EU	5.2kW	5.6kW	1/4", 1/2"	WindFree 4-Way Mini Cassette	518.00
PC4SUFMAN				WindFree Mini 4-Way Cassette Fascia Panel	162.00

WindFree™ 1way cassette



AJ026TN1DKG/EU	2.6kW	2.9kW	1/4", 3/8"	WindFree 1-Way Cassette	373.00
AJ035TN1DKG/EU	3.5kW	3.8kW	1/4", 3/8"	WindFree 1-Way Cassette	454.00
PC1NWFMAN				WindFree 1-Way Cassette Fascia Panel	162.00

PLEASE NOTE: Please see the allowed combination table in FJM TDB, for compatibility confirmation between outdoor/indoor models
Previous FJM version indoor/outdoor units are NOT compatible with NASA protocol models listed on this page

FJM - Accessories

FJM ACCESSORIES		Description	LIST PRICE €
Model Reference			

MWR-WG00JN	LCD COLOUR PREMIUM Wired Controller (NASA)	104.00
MWR-SH11N	Simplified Wired Remote Controller	101.00
AR-EH03E	WindFree & STANDARD Wireless Remote controller (SPLIT/DVM)	39.00
MIM-H04EN	Wi-Fi Receiver 2.0 FJM/CAC/DVM NASA	152.00
MIM-B14	External Contact Interface Module (remote on/off, unit operation/error output)	23.00
MIM-A00N	Interface to connect NASA wired remote controller to RAC High Wall (Check suitability)	26.00
MIM-R10N	Interface to connect RAC High Wall to Central Control network (Check outdoor suitability)	191.00
MRK-A10N	DUCT S & Slim Duct Wireless Signal Receiver Kit (requires AR-EH03E)	38.00
MRW-TA	Remote Temperature Sensor	25.00
MCM-A300N	Touch Screen Controller NASA (Centralised management of up to 128 indoor units)	704.00
MDP-M075SGU3D	Drain Pump for MSP Ducted Unit (TNM Model)	84.00

* FJM Wall Mounted indoor units require MIM-A00N interface for connection to wired controller

ERV & ERVPLUS

Heat Recovery Ventilator



Air to Air Heat Exchangers

ERV HEAT RECOVERY VENTILATION UNITS - 1 phase						
Model Reference	Description	Air Volume	Max Fuse	Rated ESP	Duct Dia	LIST PRICE €
AN026JSKLN/EU	Air to Air Heat Exchanger	260m³/h	6A	100Pa	150mm	949.00
AN035JSKLN/EU	Air to Air Heat Exchanger	350m³/h	6A	155Pa	200mm	1,193.00
AN050JSKLN/EU	Air to Air Heat Exchanger	500m³/h	6A	165Pa	200mm	1,250.00
AN080JSKLN/EU	Air to Air Heat Exchanger	800m³/h	6A	155Pa	250mm	1,709.00
AN100JSKLN/EU	Air to Air Heat Exchanger	1000m³/h	6A	155Pa	250mm	2,016.00
MOS-P1050	Differential Pressure Switch	MUST BE ORDERED WITH ABOVE TO COMPLY WITH ERP REGULATIONS				101.00



DVM Air to Air Heat Exchangers - with coil

DVM S ERV PLUS HEAT RECOVERY VENTILATION UNITS (with DX coil)							
Model Reference	Description	Air Volume	Max Fuse	Pipe Sizes	Rated ESP	Duct Dia	LIST PRICE €
AM050FNKDEH/EU	Heat Exchanger with coil for VRF	500m³/h	6A	1/4", 1/2"	160Pa	200mm	1,712.00
AM100FNKDEH/EU	Heat Exchanger with coil for VRF	1000m³/h	6A	1/4", 1/2"	150Pa	250mm	2,757.00
MOS-P1050	Differential Pressure Switch	MUST BE ORDERED WITH ABOVE TO COMPLY WITH ERP REGULATIONS				101.00	

ERV/ERV PLUS ACCESSORIES			LIST PRICE €
Model Reference	Description		
MWR-WG00JN	LCD COLOUR PREMIUM Wired Controller (NASA)		104.00
MWR-VH12N	NEW ERV Wired Remote Controller (AN***JSKLN)		48.00
MSD-EAN1	S-Plasma Ion Kit (ERV PLUS only)		76.00
MOS-C1	Carbon Dioxide Sensor		142.00
MIM-N10	NEW ERV Communication Protocol Converter - Needed if Central control interface is required		192.00
MOS-P1050	Differential Pressure Switch	MUST BE ORDERED WITH ABOVE TO COMPLY WITH ERP REGULATIONS	101.00

DVM S DIGITAL VARIABLE MULTI AHU



Air Handling Unit Kits

DVM S AHU CONNECTION KITS				LIST PRICE €
Model Reference	Description	HP		
MXD-K025AN	Air Handling Unit Connection Kit (2.5HP)	2.5		750.00
MXD-K050AN	Air Handling Unit Connection Kit (5.0HP)	5.0		798.00
MXD-K075AN	Air Handling Unit Connection Kit (7.5HP)	7.5		891.00
MXD-K100AN	Air Handling Unit Connection Kit (10.0HP)	10.0		938.00
SOLUTIONS For Capacities >10hp on same refrigeration system - use up to 4 x MXD-A64100E per control kit				
MXD-A64K100E	AHU EEV Kit (10HP) for use with MCM-D201N	10.0		142.00
MCM-D201N	Control Kit for MXD-A64K100E			333.00

COMMERCIAL SPLIT SYSTEM

AHU

Air Handling Unit Kit



CAC AHU CONNECTION KITS				LIST PRICE €
Model Reference	Description	HP		
MXD-K100XN	SPLIT Air Handling Unit Connection Kit (4-10.0HP) - 10kw to 25kW	4-10HP		709.00

NOTE: For use with R410A Commercial Split System outdoor units ONLY, see below:

Model	Capacity	LIST PRICE €
AC100KXADEH/EU	10kW	1,426.00
AC140KXADGH/EU	14kW	1,864.00
AC200KXAPNH/EU	20kW	2,857.00
AC250KXAPNH/EU	25kW	3,223.00

DVM S ECO

Digital Variable Multi



DVM - Mini VRF

DVM S ECO HEAT PUMP OUTDOOR UNITS ~ 1 PHASE

Model Reference	Type	HP	Cool	Heat	EER	CoP	Description	LIST PRICE €
SINGLE FAN								
AM040KXMDEH/EU	2-Pipe	4	12.1kW	12.1kW	3.36	4.17	DVM S Mini Inverter Heat Pump R410A 1 Phase	2,875.00
AM050KXMDEH/EU	2-Pipe	5	14.0kW	14.0kW	3.50	4.12	DVM S Mini Inverter Heat Pump R410A 1 Phase	3,245.00



DVM - Mini VRF - Heat Pump / Heat Recovery

3pipe Mini VRF

DVM S ECO HEAT PUMP/HEAT RECOVERY OUTDOOR UNITS ~ 1 PHASE

Model Reference	Type	HP	Cool	Heat	EER	CoP	Description	LIST PRICE €
2pipe/3pipe								
AM040NXMDER/EU	2 / 3 Pipe	4	12.1kW	12.1kW	4.5	4.8	DVM S Mini Inverter HP/HR R410A 1 Phase	3,172.00
AM050NXMDER/EU	2 / 3 Pipe	5	14.0kW	14.0kW	4.11	4.70	DVM S Mini Inverter HP/HR R410A 1 Phase	3,583.00
AM060NXMDER/EU	2 / 3 Pipe	6	15.5kW	15.5kW	3.75	4.45	DVM S Mini Inverter HP/HR R410A 1 Phase	3,990.00

DVM S ECO HEAT PUMP/HEAT RECOVERY OUTDOOR UNITS ~ 3 PHASE

2pipe/3pipe								
AM040NXMDGR/EU	2 / 3 Pipe	4	12.1kW	12.1kW	4.5	4.8	DVM S Mini Inverter HP/HR R410A 3 Phase	3,376.00
AM050NXMDGR/EU	2 / 3 Pipe	5	14.0kW	14.0kW	4.11	4.70	DVM S Mini Inverter HP/HR R410A 3 Phase	3,886.00
AM060NXMDGR/EU	2 / 3 Pipe	6	15.5kW	15.5kW	3.75	4.45	DVM S Mini Inverter HP/HR R410A 3 Phase	4,397.00

#3pipe HR function via MCU boxes - At least 1 x Master MCU HR required per system



DVM - Mini VRF Large Capacity

DVM S ECO HEAT PUMP OUTDOOR UNITS ~ 3 PHASE

Model Reference	Type	HP	Cool	Heat	EER	CoP	Description	LIST PRICE €
AM080FXMDGH/EU	2-Pipe	8	22.4kW	25.2kW	3.92	5.12	DVM S Mini Inverter Heat Pump R410A 3 Phase	5,522.00
AM100KXMDGH/EU	2-Pipe	10	28.0kW	31.5kW	3.84	4.67	DVM S Mini Inverter Heat Pump R410A 3 Phase	6,065.00
AM120KXMDGH/EU	2-Pipe	12	33.5kW	37.5kW	3.82	4.79	DVM S Mini Inverter Heat Pump R410A 3 Phase	7,157.00
AM140KXMDGH/EU	2-Pipe	14	40.0kW	45.0kW	3.78	4.55	DVM S Mini Inverter Heat Pump R410A 3 Phase	8,443.00

DVM S WATER

Digital Variable Multi



DVM - Water Cooled VRF - Heat Pump / Heat Recovery

DVM S WATER CONDENSING UNITS HP & HR ~ 3 PHASE

Model Reference	Type	HP	Cool	Heat	EER	CoP	Description	LIST PRICE €
2pipe/3pipe								
AM080MXWANR/EU	2 / 3 Pipe	8	22.4kW	25.2kW	6.1	6.35	DVM S Water Inverter HP/HR R410A 3 Phase	7,249.00
AM100MXWANR/EU	2 / 3 Pipe	10	28.0kW	31.5kW	5.75	6.25	DVM S Water Inverter HP/HR R410A 3 Phase	8,521.00
AM120MXWANR/EU	2 / 3 Pipe	12	33.6kW	37.8kW	5.60	6.05	DVM S Water Inverter HP/HR R410A 3 Phase	10,187.00
AM200MXWANR/EU	2 / 3 Pipe	20	39.2kW	44.1kW	5.20	5.80	DVM S Water Inverter HP/HR R410A 3 Phase	15,476.00
AM300KXWANR/EU	2 / 3 Pipe	30	84.0kW	94.5kW	5.00	5.60	DVM S Water Inverter HP/HR R410A 3 Phase	22,490.00

NB: Not for outdoor installation

#3pipe HR function via MCU boxes



DVMS2 - 3pipe Heat Recovery

NEW model

HIGH EFFICIENCY HR MODEL

DVMS2 HE HEAT RECOVERY OUTDOOR UNITS ~ 3 PHASE

Model Reference	Type	HP	Cool	Heat	SEER	SCoP	Description	LIST PRICE €
AM080AXVGGR/EU	3-Pipe	8	22.4kW	22.4kW	7.20	4.50	DVMS2 High Efficiency Heat Recovery Inverter R410A	6,959.00
AM100AXVGGR/EU	3-Pipe	10	28.0kW	28.0kW	6.90	4.40	DVMS2 High Efficiency Heat Recovery Inverter R410A	7,801.00
AM120AXVGGR/EU	3-Pipe	12	33.6kW	33.6kW	6.90	4.56	DVMS2 High Efficiency Heat Recovery Inverter R410A	9,384.00
AM140AXVGGR/EU	3-Pipe	14	40.0kW	40.0kW	6.70	4.25	DVMS2 High Efficiency Heat Recovery Inverter R410A	10,857.00
AM160AXVGGR/EU	3-Pipe	16	45.0kW	45.0kW	6.90	4.30	DVMS2 High Efficiency Heat Recovery Inverter R410A	12,859.00
AM180AXVGGR/EU	3-Pipe	18	50.4kW	50.4kW	7.50	4.80	DVMS2 High Efficiency Heat Recovery Inverter R410A	14,229.00
AM200AXVGGR/EU	3-Pipe	20	56.0kW	56.0kW	6.50	4.50	DVMS2 High Efficiency Heat Recovery Inverter R410A	15,599.00
AM220AXVGGR/EU	3-Pipe	22	61.6kW	61.6kW	6.20	4.30	DVMS2 High Efficiency Heat Recovery Inverter R410A	17,180.00
AM240AXVGGR/EU	3-Pipe	24	67.2kW	67.2kW	5.90	3.90	DVMS2 High Efficiency Heat Recovery Inverter R410A	18,799.00
AM260AXVGGR/EU	3-Pipe	26	72.8kW	72.8kW	5.40	3.90	DVMS2 High Efficiency Heat Recovery Inverter R410A	19,951.00

#3pipe HR function via MCU boxes



DVMS2 - 2pipe Heat Pump

NEW model

HIGH EFFICIENCY HP MODEL

DVMS2 HE HEAT PUMP OUTDOOR UNITS ~ 3 PHASE

Model Reference	Type	HP	Cool	Heat	SEER	SCoP	Description	LIST PRICE €
AM080AXVGGH/EU	2-Pipe	8	22.4kW	22.4kW	7.20	4.50	DVMS2 High Efficiency Heat Pump Inverter R410A	6,244.00
AM100AXVGGH/EU	2-Pipe	10	28.0kW	28.0kW	6.90	4.40	DVMS2 High Efficiency Heat Pump Inverter R410A	6,819.00
AM120AXVGGH/EU	2-Pipe	12	33.6kW	33.6kW	6.90	4.56	DVMS2 High Efficiency Heat Pump Inverter R410A	8,289.00
AM140AXVGGH/EU	2-Pipe	14	40.0kW	40.0kW	6.70	4.25	DVMS2 High Efficiency Heat Pump Inverter R410A	9,908.00
AM160AXVGGH/EU	2-Pipe	16	45.0kW	45.0kW	6.90	4.30	DVMS2 High Efficiency Heat Pump Inverter R410A	11,701.00
AM180AXVGGH/EU	2-Pipe	18	50.4kW	50.4kW	7.50	4.80	DVMS2 High Efficiency Heat Pump Inverter R410A	12,648.00
AM200AXVGGH/EU	2-Pipe	20	56.0kW	56.0kW	6.50	4.50	DVMS2 High Efficiency Heat Pump Inverter R410A	14,391.00
AM220AXVGGH/EU	2-Pipe	22	61.6kW	61.6kW	6.20	4.30	DVMS2 High Efficiency Heat Pump Inverter R410A	16,011.00
AM240AXVGGH/EU	2-Pipe	24	67.2kW	67.2kW	5.90	3.90	DVMS2 High Efficiency Heat Pump Inverter R410A	16,899.00
AM260AXVGGH/EU	2-Pipe	26	72.8kW	72.8kW	5.40	3.90	DVMS2 High Efficiency Heat Pump Inverter R410A	17,935.00



DVM - 2pipe Heat Pump

NEW model

STANDARD HP MODEL

DVMS2 STD HEAT PUMP OUTDOOR UNITS ~ 3 PHASE

Model Reference	Type	HP	Cool	Heat	SEER	SCoP	Description	LIST PRICE €
AM080AXVAGH/EU	2-Pipe	8	22.4kW	22.4kW	6.50	4.20	DVMS2 Standard Efficiency Heat Pump Inverter R410A	5,781.00
AM100AXVAGH/EU	2-Pipe	10	28.0kW	28.0kW	6.20	4.20	DVMS2 Standard Efficiency Heat Pump Inverter R410A	6,314.00
AM120AXVAGH/EU	2-Pipe	12	33.6kW	33.6kW	6.60	4.40	DVMS2 Standard Efficiency Heat Pump Inverter R410A	7,677.00
AM140AXVAGH/EU	2-Pipe	14	40.0kW	40.0kW	6.40	4.20	DVMS2 Standard Efficiency Heat Pump Inverter R410A	8,908.00
AM160AXVAGH/EU	2-Pipe	16	45.0kW	45.0kW	6.50	4.30	DVMS2 Standard Efficiency Heat Pump Inverter R410A	10,517.00
AM180AXVAGH/EU	2-Pipe	18	50.4kW	50.4kW	6.10	4.20	DVMS2 Standard Efficiency Heat Pump Inverter R410A	11,369.00
AM200AXVAGH/EU	2-Pipe	20	56.0kW	56.0kW	6.20	4.10	DVMS2 Standard Efficiency Heat Pump Inverter R410A	12,936.00
AM220AXVAGH/EU	2-Pipe	22	61.6kW	61.6kW	5.90	4.10	DVMS2 Standard Efficiency Heat Pump Inverter R410A	14,393.00
AM240AXVAGH/EU	2-Pipe	24	67.2kW	67.2kW	5.60	3.70	DVMS2 Standard Efficiency Heat Pump Inverter R410A	15,930.00
AM260AXVAGH/EU	2-Pipe	26	72.8kW	72.8kW	5.10	3.70	DVMS2 Standard Efficiency Heat Pump Inverter R410A	16,948.00

DVM S INDOOR UNITS

Model Reference Cool Heat Description

360 Cassette

LIST PRICE €

Circular 360 Cassette



AM045KN4DEH/EU	4.5kW	5.0kW	360 Cassette (947mm diameter) - price includes standard panel	998.00
AM056KN4DEH/EU	5.6kW	6.3kW	361 Cassette (947mm diameter) - price includes standard panel	1,057.00
AM071KN4DEH/EU	7.1kW	8.0kW	362 Cassette (947mm diameter) - price includes standard panel	1,147.00
AM090KN4DEH/EU	9.0kW	10.0kW	363 Cassette (947mm diameter) - price includes standard panel	1,313.00
AM112KN4DEH/EU	11.2kW	12.5kW	364 Cassette (947mm diameter) - price includes standard panel	1,507.00
AM128KN4DEH/EU	12.8kW	13.8kW	365 Cassette (947mm diameter) - price includes standard panel	1,695.00
AM140KN4DEH/EU	14.0kW	16.0kW	366 Cassette (947mm diameter) - price includes standard panel	1,813.00
PC4NUDMAN			360 Cassette Panel Square - WHITE	167.00
PC4NUNMAN			360 Cassette Panel Round - WHITE	167.00
PC4NBDMAN			360 Cassette Panel Square - BLACK	167.00
PC4NBNMAN			360 Cassette Panel Round - BLACK	167.00
PC6EUCMAN			360 Cassette Fascia Panel Square - PURE Filter	528.00
PC6EUXMAN			360 Cassette Fascia Panel Square - AutoLIFT	496.00

4-way high efficiency Cassette WindFree™

LIST PRICE €

High Efficiency 4way Cassette - WindFree™



AM028AN4PKH/EU	2.8kW	3.2kW	High Efficiency WindFree 4-Way Cassette (840mm x 840mm) - including std. Panel	807.00
AM036AN4PKH/EU	3.6kW	4.0kW	High Efficiency WindFree 4-Way Cassette (840mm x 840mm) - including std. Panel	849.00
AM045AN4PKH/EU	4.5kW	5.0kW	High Efficiency WindFree 4-Way Cassette (840mm x 840mm) - including std. Panel	895.00
AM056AN4PKH/EU	5.6kW	6.3kW	High Efficiency WindFree 4-Way Cassette (840mm x 840mm) - including std. Panel	945.00
AM071AN4PKH/EU	7.1kW	8.0kW	High Efficiency WindFree 4-Way Cassette (840mm x 840mm) - including std. Panel	986.00
AM090AN4PKH/EU	9.0kW	10.0kW	High Efficiency WindFree 4-Way Cassette (840mm x 840mm) - including std. Panel	1,124.00
AM112AN4PKH/EU	11.2kW	12.5kW	High Efficiency WindFree 4-Way Cassette (840mm x 840mm) - including std. Panel	1,225.00
AM128AN4PKH/EU	12.8kW	13.8kW	High Efficiency WindFree 4-Way Cassette (840mm x 840mm) - including std. Panel	1,455.00
AM140AN4PKH/EU	14.0kW	16.0kW	High Efficiency WindFree 4-Way Cassette (840mm x 840mm) - including std. Panel	1,556.00
PC4NUFMAN			WindFree 4-Way Cassette Fascia Panel	167.00
PC4NUCEAN			WindFree 4-Way Cassette Fascia Panel - PURE Filter	594.00
PC4NUXMAN			WindFree 4-Way Cassette Fascia Panel - AutoLIFT	414.00

4-way Cassette WindFree™

LIST PRICE €

4way Cassette - WindFree™



AM045NN4DEH/EU	4.5kW	5.0kW	WindFree 4-Way Cassette (840mm x 840mm) - price including standard panel	886.00
AM056NN4DEH/EU	5.6kW	6.3kW	WindFree 4-Way Cassette (840mm x 840mm) - price including standard panel	936.00
AM071NN4DEH/EU	7.1kW	8.0kW	WindFree 4-Way Cassette (840mm x 840mm) - price including standard panel	975.00
AM090NN4DEH/EU	9.0kW	10.0kW	WindFree 4-Way Cassette (840mm x 840mm) - price including standard panel	1,112.00
AM112NN4DEH/EU	11.2kW	12.5kW	WindFree 4-Way Cassette (840mm x 840mm) - price including standard panel	1,213.00
AM128NN4DEH/EU	12.8kW	13.8kW	WindFree 4-Way Cassette (840mm x 840mm) - price including standard panel	1,441.00
AM140NN4DEH/EU	14.0kW	16.0kW	WindFree 4-Way Cassette (840mm x 840mm) - price including standard panel	1,540.00
PC4NUFMAN			WindFree 4-Way Cassette Fascia Panel	167.00
PC4NUCEAN			WindFree 4-Way Cassette Fascia Panel - PURE Filter	594.00
PC4NUXMAN			WindFree 4-Way Cassette Fascia Panel - AutoLIFT	414.00

4-way Mini Cassette WindFree™

LIST PRICE €

4way mini Cassette - WindFree™



AM015NNNDEH/EU	1.5kW	1.7kW	WindFree Mini 4-Way Cassette (575mm x 575mm)	719.00
AM022NNNDEH/EU	2.2kW	2.5kW	WindFree Mini 4-Way Cassette (575mm x 575mm)	728.00
AM028NNNDEH/EU	2.8kW	3.2kW	WindFree Mini 4-Way Cassette (575mm x 575mm)	748.00
AM036NNNDEH/EU	3.6kW	4.0kW	WindFree Mini 4-Way Cassette (575mm x 575mm)	769.00
AM045NNNDEH/EU	4.5kW	5.0kW	WindFree Mini 4-Way Cassette (575mm x 575mm)	847.00
AM056NNNDEH/EU	5.6kW	6.3kW	WindFree Mini 4-Way Cassette (575mm x 575mm)	938.00
AM060NNNDEH/EU	6.0kW	6.8kW	WindFree Mini 4-Way Cassette (575mm x 575mm)	994.00
PC4SUFMAN			WindFree Mini 4-Way Cassette Fascia Panel - 620x620	162.00

DVM S INDOOR UNITS

Model Reference Cool Heat Description

LIST PRICE €

1-way Cassette - WindFree™



AM017NN1PEH/EU	1.7kW	1.9kW	WindFree 1-Way Cassette (740mm x 360mm) - use small panel	887.00
AM022NN1PEH/EU	2.2kW	2.5kW	WindFree 1-Way Cassette (740mm x 360mm) - use small panel	899.00
PC1MWFMAN			WindFree 1-Way Cassette Fascia Panel - Small	162.00
PC1MWCMAN			WindFree 1-Way Cassette Fascia Panel - Small - PURE Filter	473.00

AM022NN1DKH/EU	2.2kW	2.5kW	WindFree Slimline 1-Way Cassette (970mm x 410mm) - use medium panel	900.00
AM028NN1DKH/EU	2.8kW	3.2kW	WindFree Slimline 1-Way Cassette (970mm x 410mm) - use medium panel	931.00
AM036NN1DKH/EU	3.6kW	4.0kW	WindFree Slimline 1-Way Cassette (970mm x 410mm) - use medium panel	988.00
PC1NWFMAN			WindFree 1-Way Cassette Fascia Panel - Medium	162.00
PC1NWCMAN			WindFree 1-Way Cassette Fascia Panel - Medium - PURE Filter	496.00

AM056NN1DEH/EU	5.6kW	6.3kW	WindFree Slimline 1-Way Cassette (1200mm x 450mm) - use large panel	1,084.00
AM071NN1DEH/EU	7.1kW	8.0kW	WindFree Slimline 1-Way Cassette (1200mm x 450mm) - use large panel	1,146.00
PC1BWFMAN			WindFree 1-Way Cassette Fascia Panel - Large	162.00
PC1BWCMAN			WindFree 1-Way Cassette Fascia Panel - Large - PURE Filter	563.00

Slimline Ducted

LIST PRICE €

Slim Duct



AM017ANLDKH/EU	1.7kW	1.9kW	Slimline Ducted Unit	644.00
AM022ANLDKH/EU	2.2kW	2.5kW	Slimline Ducted Unit	673.00
AM028ANLDKH/EU	2.8kW	3.2kW	Slimline Ducted Unit	709.00
AM036ANLDKH/EU	3.6kW	4.0kW	Slimline Ducted Unit	728.00
AM045ANLDKH/EU	4.5kW	5.0kW	Slimline Ducted Unit	777.00
AM056ANLDKH/EU	5.6kW	6.3kW	Slimline Ducted Unit	883.00
AM071ANLDKH/EU	7.1kW	8.0kW	Slimline Ducted Unit	933.00
AM090ANLDKH/EU	9.0kW	10.0kW	Slimline Ducted Unit	1,349.00
AM112ANLDKH/EU	11.2kW	12.5kW	Slimline Ducted Unit	1,481.00
AM128ANLDKH/EU	12.8kW	13.8kW	Slimline Ducted Unit	1,534.00
AM140ANLDKH/EU	14.0kW	16.0kW	Slimline Ducted Unit	1,602.00

NEW 2021 Model

Slimline Ducted

LIST PRICE €

AM017FNLDEH/EU	1.7kW	1.9kW	Slimline Ducted Unit	644.00
AM022FNLDEH/EU	2.2kW	2.5kW	Slimline Ducted Unit	673.00
AM028FNLDEH/EU	2.8kW	3.2kW	Slimline Ducted Unit	709.00
AM036FNLDEH/EU	3.6kW	4.0kW	Slimline Ducted Unit	728.00
AM045FNLDEH/EU	4.5kW	5.0kW	Slimline Ducted Unit	777.00
AM056FNLDEH/EU	5.6kW	6.3kW	Slimline Ducted Unit	883.00
AM071FNLDEH/EU	7.1kW	8.0kW	Slimline Ducted Unit	933.00
AM090FNLDEH/EU	9.0kW	10.0kW	Slimline Ducted Unit	1,349.00
AM112FNLDEH/EU	11.2kW	12.5kW	Slimline Ducted Unit	1,481.00
AM128FNLDEH/EU	12.8kW	13.8kW	Slimline Ducted Unit	1,534.00
AM140FNLDEH/EU	14.0kW	16.0kW	Slimline Ducted Unit	1,602.00

whilst stocks last

Slimline Ducted with condensate pump

LIST PRICE €

AM017KNLDEH/EU	1.7kW	1.9kW	Slimline Ducted Unit with built-in condensate pump	715.00
AM022KNLDEH/EU	2.2kW	2.5kW	Slimline Ducted Unit with built-in condensate pump	748.00
AM028KNLDEH/EU	2.8kW	3.2kW	Slimline Ducted Unit with built-in condensate pump	777.00
AM036KNLDEH/EU	3.6kW	4.0kW	Slimline Ducted Unit with built-in condensate pump	798.00
AM045MNLDEH/EU	4.5kW	5.0kW	Slimline Ducted Unit with built-in condensate pump	849.00
AM056MNLDEH/EU	5.6kW	6.3kW	Slimline Ducted Unit with built-in condensate pump	953.00
AM071MNLDEH/EU	7.1kW	8.0kW	Slimline Ducted Unit with built-in condensate pump	1,004.00
AM090MNLDKH/EU	9.0kW	10.0kW	Slimline Ducted Unit with built-in condensate pump	1,420.00
AM112MNLDKH/EU	11.2kW	12.5kW	Slimline Ducted Unit with built-in condensate pump	1,551.00
AM128MNLDKH/EU	12.8kW	13.8kW	Slimline Ducted Unit with built-in condensate pump	1,603.00
AM140MNLDKH/EU	14.0kW	16.0kW	Slimline Ducted Unit with built-in condensate pump	1,676.00

NEW 2021 Model

Slimline Ducted with condensate pump

LIST PRICE €

AM045KNLDEH/EU	4.5kW	5.0kW	Slimline Ducted Unit with built-in condensate pump	849.00
AM056KNLDEH/EU	5.6kW	6.3kW	Slimline Ducted Unit with built-in condensate pump	953.00
AM071KNLDEH/EU	7.1kW	8.0kW	Slimline Ducted Unit with built-in condensate pump	1,004.00
AM090KNLDEH/EU	9.0kW	10.0kW	Slimline Ducted Unit with built-in condensate pump	1,420.00
AM112KNLDEH/EU	11.2kW	12.5kW	Slimline Ducted Unit with built-in condensate pump	1,551.00
AM128KNLDEH/EU	12.8kW	13.8kW	Slimline Ducted Unit with built-in condensate pump	1,603.00
AM140KNLDEH/EU	14.0kW	16.0kW	Slimline Ducted Unit with built-in condensate pump	1,676.00

DVM S INDOOR UNITS

Model Reference	Cool	Heat	Description
-----------------	------	------	-------------

MSP Duct S

LIST PRICE €

Mid Static Duct S



AM022ANMPKH/EU	2.2kW	2.5kW	Duct S MSP Ducted Unit - Built-in Condensate Pump	831.00
AM028ANMPKH/EU	2.8kW	3.2kW	Duct S MSP Ducted Unit - Built-in Condensate Pump	856.00
AM036ANMPKH/EU	3.6kW	4.0kW	Duct S MSP Ducted Unit - Built-in Condensate Pump	883.00
AM045ANMPKH/EU	4.5kW	5.0kW	Duct S MSP Ducted Unit - Built-in Condensate Pump	916.00
AM056ANMPKH/EU	5.6kW	6.3kW	Duct S MSP Ducted Unit - Built-in Condensate Pump	968.00
AM071ANMPKH/EU	7.1kW	8.0kW	Duct S MSP Ducted Unit - Built-in Condensate Pump	1,001.00
AM090ANMPKH/EU	9.0kW	10.0kW	Duct S MSP Ducted Unit - Built-in Condensate Pump	1,343.00
AM112ANMPKH/EU	11.2kW	12.5kW	Duct S MSP Ducted Unit - Built-in Condensate Pump	1,460.00
AM128ANMPKH/EU	12.8kW	13.8kW	Duct S MSP Ducted Unit - Built-in Condensate Pump	1,499.00
AM140ANMPKH/EU	14.0kW	16.0kW	Duct S MSP Ducted Unit - Built-in Condensate Pump	1,596.00

NEW 2021 Model

MSP Duct S

LIST PRICE €

AM036HNMPKH/EU	3.6kW	4.0kW	Duct S MSP Ducted Unit	841.00
AM045HNMPKH/EU	4.5kW	5.0kW	Duct S MSP Ducted Unit	873.00
AM056HNMPKH/EU	5.6kW	6.3kW	Duct S MSP Ducted Unit	922.00
AM071HNMPKH/EU	7.1kW	8.0kW	Duct S MSP Ducted Unit	953.00
AM090HNMPKH/EU	9.0kW	10.0kW	Duct S MSP Ducted Unit	1,280.00
AM112HNMPKH/EU	11.2kW	12.5kW	Duct S MSP Ducted Unit	1,389.00
AM128HNMPKH/EU	12.8kW	13.8kW	Duct S MSP Ducted Unit	1,428.00
AM140HNMPKH/EU	14.0kW	16.0kW	Duct S MSP Ducted Unit	1,519.00

whilst stocks last

MSP Ducted

LIST PRICE €

Mid Static Duct



AM022FNMDEH/EU	2.2kW	2.5kW	MSP Ducted Unit	789.00
AM028FNMDEH/EU	2.8kW	3.2kW	MSP Ducted Unit	811.00
AM036FNMDEH/EU	3.6kW	4.0kW	MSP Ducted Unit	828.00
AM045FNMDEH/EU	4.5kW	5.0kW	MSP Ducted Unit	861.00
AM056FNMDEH/EU	5.6kW	6.3kW	MSP Ducted Unit	915.00
AM071FNMDEH/EU	7.1kW	8.0kW	MSP Ducted Unit	943.00
AM090FNMDEH/EU	9.0kW	10.0kW	MSP Ducted Unit	1,243.00
AM112FNMDEH/EU	11.2kW	12.5kW	MSP Ducted Unit	1,364.00

whilst stocks last

MSP Ducted with condensate pump

LIST PRICE €

AM022KNMDEH/EU	2.2kW	2.5kW	MSP Ducted Unit with built-in condensate pump	861.00
AM028KNMDEH/EU	2.8kW	3.2kW	MSP Ducted Unit with built-in condensate pump	882.00
AM036KNMDEH/EU	3.6kW	4.0kW	MSP Ducted Unit with built-in condensate pump	903.00
AM045KNMDEH/EU	4.5kW	5.0kW	MSP Ducted Unit with built-in condensate pump	935.00
AM056KNMDEH/EU	5.6kW	6.3kW	MSP Ducted Unit with built-in condensate pump	985.00
AM071KNMDEH/EU	7.1kW	8.0kW	MSP Ducted Unit with built-in condensate pump	1,015.00
AM090KNMDEH/EU	9.0kW	10.0kW	MSP Ducted Unit with built-in condensate pump	1,314.00
AM112KNMDEH/EU	11.2kW	12.5kW	MSP Ducted Unit with built-in condensate pump	1,434.00

whilst stocks last

HSP Ducted with condensate pump

LIST PRICE €

High Static Duct



AM056ANHPKH/EU	5.6kW	6.3kW	HSP Ducted Unit - Built-in Condensate Pump	1,322.00
AM071ANHPKH/EU	7.1kW	8.0kW	HSP Ducted Unit - Built-in Condensate Pump	1,469.00
AM090ANHPKH/EU	9.0kW	10.0kW	HSP Ducted Unit - Built-in Condensate Pump	1,633.00
AM112ANHPKH/EU	11.2kW	12.5kW	HSP Ducted Unit - Built-in Condensate Pump	1,737.00
AM128ANHPKH/EU	12.8kW	13.8kW	HSP Ducted Unit - Built-in Condensate Pump	1,780.00
AM140ANHPKH/EU	14.0kW	16.0kW	HSP Ducted Unit - Built-in Condensate Pump	1,827.00

NEW 2021 Model

HSP Ducted

LIST PRICE €

AM112HNHPKH/EU	11.2kW	12.5kW	HSP Ducted Unit	1,655.00
AM128HNHPKH/EU	12.8kW	13.8kW	HSP Ducted Unit	1,695.00
AM140HNHPKH/EU	14.0kW	16.0kW	HSP Ducted Unit	1,739.00

whilst stocks last

HSP Ducted - Large

LIST PRICE €

High Static Duct - Large



AM180JNHFKH/EU	18.0kW	20.0kW	Large HSP Ducted Unit	2,394.00
AM220FNHDEH/EU	22.0kW	25.0kW	Large HSP Ducted Unit	2,813.00
AM280FNHDEH/EU	28.0kW	31.5kW	Large HSP Ducted Unit	2,912.00

DVM S INDOOR UNITS
 Model Reference Cool Heat Description
 Ceiling/Floor (No EEV) - please order EEV accessory LIST PRICE €

Ceiling/Floor



AM056FNCDEH/EU	5.6kW	6.3kW	Under Ceiling / Floor Standing Unit	923.00
AM071FNCDEH/EU	7.1kW	8.0kW	Under Ceiling / Floor Standing Unit	1,026.00
MEV-E32SA			EEV Kit (1 Indoor) > 4kW	114.00

Ceiling Suspended LIST PRICE €

Ceiling Suspended



AM112JNC DKH/EU	11.2kW	12.5kW	Under Ceiling Unit	1,506.00
AM140JNC DKH/EU	14.0kW	16.0kW	Under Ceiling Unit	1,683.00

Console - Floor - Spi filter & infra-red remote control as standard LIST PRICE €

Floor



AM022KNJDEH/EU	2.2kW	2.5kW	Console Floor Standing Unit	817.00
AM028FNJDEH/EU	2.8kW	3.2kW	Console Floor Standing Unit	875.00
AM036FNJDEH/EU	3.6kW	4.0kW	Console Floor Standing Unit	923.00
AM045KNJDEH/EU	4.5kW	5.0kW	Console Floor Standing Unit	971.00
AM056FNJDEH/EU	5.6kW	6.3kW	Console Floor Standing Unit	974.00

Hi-Static Floor Standing Chassis (un-cased) LIST PRICE €

Floor uncased



AM036MNFDEH/EU	3.6kW	4.0kW	High Static 60Pa Floor Standing Chassis (un-cased) Unit	813.00
AM056MNFDEH/EU	5.6kW	6.3kW	High Static 60Pa Floor Standing Chassis (un-cased) Unit	905.00
AM071MNFDEH/EU	7.1kW	8.0kW	High Static 60Pa Floor Standing Chassis (un-cased) Unit	953.00

PAC Cabinet Floor Standing - built in controls (wired remote optional) LIST PRICE €

PAC Cabinet Floor



AM140RNPDKH/EU	14kW	16kW	PAC Cabinet Floor Unit	1,693.00
AM280RNPDKH/EU	28kW	31.5kW	PAC Cabinet Floor Unit	2,618.00

Outdoor Air Processing(OAP) Unit LIST PRICE €

OAP Unit



AM140MNEPEH/EU	14.0kW	16.0kW	OAP (Outdoor Air Processing Ducted Unit)	1,933.00
AM220MNEPEH/EU	22.0kW	25.0kW	OAP (Outdoor Air Processing Ducted Unit)	3,200.00
AM280MNEPEH/EU	28.0kW	31.5kW	OAP (Outdoor Air Processing Ducted Unit)	3,492.00

DVM S INDOOR UNITS

Model Reference	Cool	Heat	Description	LIST PRICE €
-----------------	------	------	-------------	--------------

WindFree™ High Wall



Wall Mounted - WindFree (No EEV) - please order EEV accessory				LIST PRICE €
---	--	--	--	--------------

AM015TNADKH/EU	1.5kW	1.7kW	WindFree High Wall Mounted Unit (No EEV)	601.00
AM022TNADKH/EU	2.2kW	2.5kW	WindFree High Wall Mounted Unit (No EEV)	629.00
AM028TNADKH/EU	2.8kW	3.2kW	WindFree High Wall Mounted Unit (No EEV)	651.00
AM036TNADKH/EU	3.6kW	4.0kW	WindFree High Wall Mounted Unit (No EEV)	675.00
AM045TNADKH/EU	4.5kW	5.0kW	WindFree High Wall Mounted Unit (No EEV)	726.00
AM056TNADKH/EU	5.6kW	6.3kW	WindFree High Wall Mounted Unit (No EEV)	768.00
AM071TNADKH/EU	6.8kW	7.0kW	WindFree High Wall Mounted Unit (No EEV)	811.00
AM082TNADKH/EU	8.2kW	8.5kW	WindFree High Wall Mounted Unit (No EEV)	867.00
MEV-E24SA			EEV Kit (1 Indoor) <4kW	104.00
MEV-E32SA			EEV Kit (1 Indoor) > 4kW	114.00

Wall Mounted - WindFree (with EEV)				LIST PRICE €
------------------------------------	--	--	--	--------------

AM015TNVDKH/EU	1.5kW	1.7kW	WindFree High Wall Mounted Unit (With EEV)	719.00
AM022TNVDKH/EU	2.2kW	2.5kW	WindFree High Wall Mounted Unit (With EEV)	743.00
AM028TNVDKH/EU	2.8kW	3.2kW	WindFree High Wall Mounted Unit (With EEV)	768.00
AM036TNVDKH/EU	3.6kW	4.0kW	WindFree High Wall Mounted Unit (With EEV)	788.00
AM045TNVDKH/EU	4.5kW	5.0kW	WindFree High Wall Mounted Unit (With EEV)	821.00
AM056TNVDKH/EU	5.6kW	6.3kW	WindFree High Wall Mounted Unit (With EEV)	856.00
AM071TNVDKH/EU	6.8kW	7.0kW	WindFree High Wall Mounted Unit (With EEV)	936.00
AM082TNVDKH/EU	8.2kW	8.5kW	WindFree High Wall Mounted Unit (With EEV)	1,013.00

High Wall Std



Wall Mounted - Boracay (No EEV) - please order EEV accessory				LIST PRICE €
--	--	--	--	--------------

AM015KNTDEH/EU	1.5kW	1.7kW	Boracay High Wall Mounted Unit (No EEV)	533.00
AM022KNTDEH/EU	2.2kW	2.5kW	Boracay High Wall Mounted Unit (No EEV)	553.00
AM028KNTDEH/EU	2.8kW	3.2kW	Boracay High Wall Mounted Unit (No EEV)	579.00
AM036KNTDEH/EU	3.6kW	4.0kW	Boracay High Wall Mounted Unit (No EEV)	594.00
AM045KNTDEH/EU	4.5kW	5.0kW	Boracay High Wall Mounted Unit (No EEV)	617.00
AM056KNTDEH/EU	5.6kW	6.3kW	Boracay High Wall Mounted Unit (No EEV)	645.00
AM071KNTDEH/EU	6.8kW	7.0kW	Boracay High Wall Mounted Unit (No EEV)	716.00
MEV-E24SA			EEV Kit (1 Indoor) <4kW	104.00
MEV-E32SA			EEV Kit (1 Indoor) > 4kW	114.00

Wall Mounted - Boracay (with EEV)				LIST PRICE €
-----------------------------------	--	--	--	--------------

AM015KNQDEH/EU	1.5kW	1.7kW	Boracay-E High Wall Mounted Unit (With EEV)	624.00
AM022KNQDEH/EU	2.2kW	2.5kW	Boracay-E High Wall Mounted Unit (With EEV)	643.00
AM028KNQDEH/EU	2.8kW	3.2kW	Boracay-E High Wall Mounted Unit (With EEV)	663.00
AM036KNQDEH/EU	3.6kW	4.0kW	Boracay-E High Wall Mounted Unit (With EEV)	683.00
AM045KNQDEH/EU	4.5kW	5.0kW	Boracay-E High Wall Mounted Unit (With EEV)	712.00
AM056KNQDEH/EU	5.6kW	6.3kW	Boracay-E High Wall Mounted Unit (With EEV)	739.00
AM071KNQDEH/EU	6.8kW	7.0kW	Boracay-E High Wall Mounted Unit (With EEV)	810.00

Large Wall



Large Wall Mounted - (with EEV)				LIST PRICE €
---------------------------------	--	--	--	--------------

AM093MNNQDEH/EU	9.3kW	9.8kW	High Wall Mounted Unit (With EEV)	1,221.00
-----------------	-------	-------	-----------------------------------	----------

DVM S EHS

Digital Variable Multi

80°C Hydro unit



EHS Hydro Box Indoor HT - 80°C				LIST PRICE €
--------------------------------	--	--	--	--------------

AM160TNBFEB/EU	~	16.0kW	EHS A2W DVM S HT Hydro Unit R134a/R410A	4,014.00
AM250TNBFEB/EU	~	25.0kW	EHS A2W DVM S HT Hydro Unit R134a/R410A	4,754.00
MWR-WW10N			DVM S EHS HE/HT LCD Colour Hard Wired Remote Controller	104.00

~ 3-phase available on request at additional cost - AM***TNBFG B/EU

50°C Hydro unit



EHS Hydro Box Indoor HE - 50°C				LIST PRICE €
--------------------------------	--	--	--	--------------

AM160FNBDEH/EU	14.0kW	16.0kW	EHS A2W DVM S HE Hydro Unit R410A	1,457.00
AM320FNBDEH/EU	28.0kW	32.0kW	EHS A2W DVM S HE Hydro Unit R410A	2,169.00
AM500FNBDEH/EU	44.8kW	50.0kW	EHS A2W DVM S HE Hydro Unit R410A - ONLY for use with 2pipe HP DVM outdoors	2,541.00
MWR-WW10N			DVM S EHS HE/HT LCD Colour Hard Wired Remote Controller	99.00



Accessories

DVM S MCU - HR 3pipe Mode Control Units

Model Reference	Type	Type	Description	LIST PRICE €
<i>For use with DVM S Eco HR (Mini VRF) - add 1, 2, 4 & 6 port MCU to match number of indoor unit connections</i>				
MCU-R4NEK0N	4 Port	ECO HR	MASTER 4-port HR MCU Kit <22.4kW (<5.6kW per port) - DVM S Eco HR	1,607.00

For use with all HR outdoors - including the DVM S eco in addition to HR Master MCU above

MCU-S1NEK1N	1 Port	3-Pipe	1-port MCU Kit <16kW	675.00
MCU-S2NEK2N	2 Port	3-Pipe	2-port MCU Kit <32kW (<16kW per port) - Serial connection possible	1,006.00
MCU-S4NEK3N	4 Port	3-Pipe	4-port MCU Kit <61.6kW (<16kW per port) - Serial connection possible	1,514.00
MCU-S6NEK2N	6 Port	3-Pipe	6-port MCU Kit <61.6kW (<16kW per port) - Serial connection possible	1,852.00
MCU-S6NEK3N	6 Port	3-Pipe	6-port MCU Kit <22.4kW (<5.6kW per port) - Serial connection possible	1,964.00

DVM S PIPE JOINTS

Model Reference	Connect	Type	Description	LIST PRICE €
MXJ-YA1509M	IU	2-Pipe	Y-Joint (<15kW)	62.00
MXJ-YA2512M	IU	2-Pipe	Y-Joint to (15.1kW > 40kW)	105.00
MXJ-YA2812M	IU	2-Pipe	Y-Joint (40.1kW to 45kW)	130.00
MXJ-YA2815M	IU	2-Pipe	Y-Joint (45.1kW to 70.3kW)	130.00
MXJ-YA3419M	IU	2-Pipe	Y-Joint (70.4kW to 98.4kW)	156.00
MXJ-YA4119M	IU	2-Pipe	Y-Joint (98.5kW to 135.2kW)	186.00
MXJ-YA4422M	IU	2-Pipe	Y-Joint (>135.2kW)	334.00
MXJ-YA1500M	IU	3-Pipe	additional Y-Joint (<22.4kW) Discharge pipe*	49.00
MXJ-YA2500M	IU	3-Pipe	additional Y-Joint (22.5kW to 67.3kW) Discharge pipe*	82.00
MXJ-YA3100M	IU	3-Pipe	additional Y-Joint (67.4kW to 135.2kW) Discharge pipe*	124.00
MXJ-YA3800M	IU	3-Pipe	additional Y-Joint (>135.2kW) Discharge pipe*	130.00

*+ 2-Pipe Y-Joint above

MXJ-YM1206R	IU	3-Pipe	6-14kW Connection from 1 MCU port (MCU-R4NEK0N only)	44.00
MXJ-YM1206M	IU	3-Pipe	6-14W Connection from 1 MCU port (MCU-S6NEK3N only)	57.00
MXJ-YM1509M	IU	3-Pipe	16-28kW Connection from 1 MCU port (2/4/6 MCU)	63.00

MXJ-HA2512M	IU	2-Pipe	4 way Header Joint (< 45.0kW)	67.00
MXJ-HA3115M	IU	2-Pipe	8 way Header Joint (< 70.3kW)	186.00
MXJ-HA3819M	IU	2-Pipe	8 way Header Joint (> 70.4kW)	192.00

MXJ-TA3419M	OU	2-Pipe	<49HP Multiple Outdoor Unit Connection Joint (<135.2kW)	160.00
MXJ-TA3819M	OU	2-Pipe	<49HP Multiple Outdoor Unit Connection Joint (<135.2kW)	133.00
MXJ-TA4122M	OU	2-Pipe	>50HP Multiple Outdoor Unit Connection Joint (>140.2kW)	218.00
MXJ-TA4422M	OU	2-Pipe	>50HP Multiple Outdoor Unit Connection Joint (>140.2kW)	218.00

MXJ-TA3100M	OU	3-Pipe	<49HP Outdoor Unit Connection Joint (<135.2kW) Discharge pipe*	95.00
MXJ-TA3800M	OU	3-Pipe	>50HP Outdoor Unit Connection Joint (>140.2kW) Discharge pipe*	107.00

*+ 2-Pipe Y-Joint above

MXD-A12K2A	OU	PDM	Pressure Drop Modulation Kit (8HP to 12HP)	122.00
MXD-A38K2A	OU	PDM	Pressure Drop Modulation Kit (14HP to 16HP)	142.00
MXD-A58K2A	OU	PDM	Pressure Drop Modulation Kit (18HP to 26HP)	150.00

DVM S INDOOR UNIT EEV Kits for Wall & Ceiling units

* Electronic Expansion Valve Kits for Boracay Wall AM...KNTDEH, AM...TNADKH & Ceiling AM...FNCDEH

Model Reference	Type	Description	LIST PRICE €
MEV-E24SA	EEV Kit (1 Indoor)	<4kW	104.00
MEV-E32SA	EEV Kit (1 Indoor)	>4kW	114.00
MXD-E24K132A	EEV Kit (2 Indoor)	port 1 <4kW, port 2 >4kW	274.00
MXD-E24K200A	EEV Kit (2 Indoor)	port 1 <4kW, port 2 <4kW	274.00
MXD-E32K200A	EEV Kit (2 Indoor)	port 1 >4kW, port 2 >4kW	274.00
MXD-E24K232A	EEV Kit (3 Indoor)	port 1 <4kW, port 2 <4kW, port 3 >4kW	348.00
MXD-E24K300A	EEV Kit (3 Indoor)	port 1 <4kW, port 2 <4kW, port 3 <4kW	348.00
MXD-E32K224A	EEV Kit (3 Indoor)	port 1 <4kW, port 2 >4kW, port 3 >4kW	348.00
MXD-E32K300A	EEV Kit (3 Indoor)	port 1 >4kW, port 2 >4kW, port 3 >4kW	348.00

DVM S OUTDOOR - CONDENSER FIN GUARD

Model Reference	Description	LIST PRICE €
MOK-100GA	External DVMS OU Condenser Guard - Single Fan up blow (8 - 12HP)	67.00
MOK-200GA	External DVMS OU Condenser Guard - Double Fan up blow (14 - 22HP)	98.00
MOK-300GA	External Super DVMS OU Condenser Guard - Double Fan (24, 26HP)	169.00

DIAGNOSTIC TOOLS

Model Reference	Description	LIST PRICE €
MIM-C02N	S Net Pro Converter (USB)	208.00

DVM S2 | WindFree™

Digital Variable Multi Compatible

Controls, Accessories & Pumps



DVM S INTERFACES & CONTROLS

Model Reference	Description	LIST PRICE €
-----------------	-------------	--------------

INDIVIDUAL CONTROLS

Model Reference	Description	LIST PRICE €
MWR-WG00JN	LCD COLOUR PREMIUM Wired Controller (NASA)	104.00
MWR-SH11N	Touch Simplified Wired Remote Controller - WindFree™ (NASA)	101.00
MWR-WW10N	DVM S EHS HE/HT LCD Colour Hard Wired Remote Controller	104.00
AR-KH03E	360 Wireless Remote controller (SPLIT/DVM)	39.00
AR-EH03E	WindFree & STANDARD Wireless Remote controller (SPLIT/DVM)	39.00
MRK-A10N	DUCT S & Slim Duct Wireless Signal Receiver Kit (requires AR-EH03E)	38.00
MIM-H04EN	Wi-Fi Receiver 2.0 for NASA SPLIT/DVM IU	152.00

CENTRAL CONTROLS

Model Reference	Description	LIST PRICE €
MCM-A300N	Touch Screen Controller (Centralised management of up to 128 indoor units)	704.00
MCM-A202DN	Centralised On/Off Controller (maximum of 16 Group controls (maximum of 256 indoor units)	110.00

BMS GATEWAYS & INTERFACES

Model Reference	Description	LIST PRICE €
MIM-D01AN	Data Management Server (DVM/FJM/CAC/ERV) central management of up to 256 indoor units, web server	1,212.00
MIM-B16N	Pulse Input Module (PIM) - Watt Hour Meter Interface Module (connect up to 8 watt hour meters)	338.00
MIM-B17BN	BACnet DMS 2 (Data Management Server with Built in BACnet Gateway - maximum 256 indoor units)	2,231.00
MIM-B18BN	LONWorks DMS 2 (Data Management Server with Built in LONWorks Gateway - maximum 128 indoor units)	2,231.00
MIM-B19N	MODBUS interface Module 48 indoor units (1 outdoor)	153.00
MST-BL1A	b.IoT Lite PC software for DVM S systems - Optimal central control of small & medium size buildings	1,309.00
MST-P3P	SNET-3 Web server Software - connect upto 16 DMS & control upto 4096 indoor units	1,912.00

DIAGNOSTIC TOOLS

Model Reference	Description	LIST PRICE €
MIM-C02N	S Net Pro Converter (USB)	208.00

INTERFACES & ACCESSORIES

Model Reference	Description	LIST PRICE €
MIM-B14	External Contact Interface Module (remote on/off, unit operation/error output)	23.00
MIM-B14A	Leak Detection Contact Interface	30.00
MRW-TA	Remote Temperature Sensor	25.00
MCM-C200	Mode Selection Switch - operation mode selection (cooling, heating, auto)	61.00
MCM-C210N	Multi Tenant Function Controller	78.00
MCR-SMC	Motion detect sensor for 4-way Cassette (WindFree) - for 950x950 panel	77.00
MCR-SMD	Motion detect sensor for 4-way Mini Cassette (WindFree) - for 620x620 panel	77.00
MCR-SME	Motion detect sensor for 360 Cassette - for SQUARE panel	77.00
MSD-CAN1	S-Plasma Ion Kit for 4way & 360 Cassette	76.00
MSD-EAN1	S-Plasma Ion Healthy Air Provider for Ducted (Duct S)	76.00
MIM-N01	NASA to RS485 - forwards and backward communications protocol converter	192.00
MOK-200DA	L shape Drain for 1way cassette - Travelodge Spec	15.00

DVM S CASSETTE INDOOR UNIT PANELS

Model Reference	Description	LIST PRICE €
PC4NUDMAN	360 Cassette Panel Square	167.00
PC4NUNMAN	360 Cassette Panel Round	167.00
PC4NBDMAN	360 Cassette Panel Square - BLACK	167.00
PC4NBNMAN	360 Cassette Panel Round - BLACK	167.00
PC6EUCMAN	360 Cassette Fascia Panel Square - PURE Filter	528.00
PC6EUXMAN	360 Cassette Fascia Panel Square - AutoLIFT	496.00
PC4NUFMAN	WindFree 4-Way Cassette Fascia Panel	167.00
PC4SUFMAN	WindFree Mini 4-Way Cassette Fascia Panel - 620x620	162.00
PC4NUCEAN	WindFree 4-Way Cassette Fascia Panel - PURE Filter	594.00
PC4NUXMAN	WindFree 4-Way Cassette Fascia Panel - AutoLIFT	414.00
PC1MWFMAN	WindFree 1-Way Cassette Fascia Panel - small	162.00
PC1NWFMAN	WindFree 1-Way Cassette Fascia Panel - medium	162.00
PC1BWFMAN	WindFree 1-Way Cassette Fascia Panel - large	162.00
PC1MWCMAN	WindFree 1-Way Cassette Fascia Panel - Small - PURE Filter	473.00
PC1NWCMAN	WindFree 1-Way Cassette Fascia Panel - Medium - PURE Filter	496.00
PC1BWCMAN	WindFree 1-Way Cassette Fascia Panel - Large - PURE Filter	563.00

DVM S INDOOR - DRAIN PUMPS

Model Reference	Description	LIST PRICE €
MDP-G075SP	Drain Pump for DUCT S Ducted Unit (External Assembly)	84.00
MDP-G075SQ	Drain Pump for DUCT S Ducted Unit (Internal Assembly)	84.00
MDP-E075SEE3D	Drain Pump for Slimline Ducted Unit (FNL model) & 2.2, 2.8 & 3.6kW ducted (FNM model)	89.00
MDP-M075SGU3D	Drain Pump for MSP Ducted Unit 4.5kW to 7.1kW - (FNM Model)	84.00
MDP-M075SGU1D	Drain Pump for MSP Ducted Unit 9.0kW to 11.2kW - (FNM Model)	84.00
MDP-M075SGU2D	Drain Pump for OAP model - AM140MNEPEH/EU	84.00
MDP-N047SNC1D	Drain Pump for HSP Ducted Unit (22kW & 28kW)	95.00

Type	New Model Code	kW	Description	Old Model	Old Model	Old Model
1way cassette	AM022NN1DKH/EU	2.2	Wind-free medium size	AM022NN1DEH/EU		
1way cassette	AM028NN1DKH/EU	2.8	Wind-free medium size	AM028NN1DEH/EU		
1way cassette	AM036NN1DKH/EU	3.6	Wind-free medium size	AM036NN1DEH/EU		
4way cassette	AM028AN4PKH/EU	2.8	Wind-free higher efficiency	NEW size		
4way cassette	AM036AN4PKH/EU	3.6	Wind-free higher efficiency	NEW size		
4way cassette	AM045AN4PKH/EU	4.5	Wind-free higher efficiency	AM045NN4DEH/EU		
4way cassette	AM056AN4PKH/EU	5.6	Wind-free higher efficiency	AM056NN4DEH/EU		
4way cassette	AM071AN4PKH/EU	7.1	Wind-free higher efficiency	AM071NN4DEH/EU		
4way cassette	AM090AN4PKH/EU	9	Wind-free higher efficiency	AM090NN4DEH/EU		
4way cassette	AM112AN4PKH/EU	11.2	Wind-free higher efficiency	AM112NN4DEH/EU		
4way cassette	AM128AN4PKH/EU	12.8	Wind-free higher efficiency	AM128NN4DEH/EU		
4way cassette	AM140AN4PKH/EU	14	Wind-free higher efficiency	AM140NN4DEH/EU		
Ducted slim	AM017ANLDKH/EU	1.7	Slim duct no Pump	AM017FNLDEH/EU		
Ducted slim	AM022ANLDKH/EU	2.2	Slim duct no Pump	AM022FNLDEH/EU		
Ducted slim	AM028ANLDKH/EU	2.8	Slim duct no Pump	AM028FNLDEH/EU		
Ducted slim	AM036ANLDKH/EU	3.6	Slim duct no Pump	AM036FNLDEH/EU		
Ducted slim	AM045ANLDKH/EU	4.5	Slim duct no Pump	AM045FNLDEH/EU		
Ducted slim	AM056ANLDKH/EU	5.6	Slim duct no Pump	AM056FNLDEH/EU		
Ducted slim	AM071ANLDKH/EU	7.1	Slim duct no Pump	AM071FNLDEH/EU		
Ducted slim	AM090ANLDKH/EU	9	Slim duct no Pump	AM090FNLDEH/EU		
Ducted slim	AM112ANLDKH/EU	11.2	Slim duct no Pump	AM112FNLDEH/EU		
Ducted slim	AM128ANLDKH/EU	12.8	Slim duct no Pump	AM128FNLDEH/EU		
Ducted slim	AM140ANLDKH/EU	14	Slim duct no Pump	AM140FNLDEH/EU		
Ducted slim	AM017KNLDEH/EU	1.7	Slim duct WITH Pump			
Ducted slim	AM022KNLDEH/EU	2.2	Slim duct WITH Pump			
Ducted slim	AM028KNLDEH/EU	2.8	Slim duct WITH Pump			
Ducted slim	AM036KNLDEH/EU	3.6	Slim duct WITH Pump			
Ducted slim	AM045MNLDEH/EU	4.5	Slim duct WITH Pump	AM045KNLDEH/EU		
Ducted slim	AM056MNLDEH/EU	5.6	Slim duct WITH Pump	AM056KNLDEH/EU		
Ducted slim	AM071MNLDEH/EU	7.1	Slim duct WITH Pump	AM071KNLDEH/EU		
Ducted slim	AM090MNLDEH/EU	9	Slim duct WITH Pump	AM090KNLDEH/EU		
Ducted slim	AM112MNLDEH/EU	11.2	Slim duct WITH Pump	AM112KNLDEH/EU		
Ducted slim	AM128MNLDEH/EU	12.8	Slim duct WITH Pump	AM128KNLDEH/EU		
Ducted slim	AM140MNLDEH/EU	14	Slim duct WITH Pump	AM140KNLDEH/EU		
Ducted MSP	AM022ANMPKH/EU	2.2	Duct S WITH Pump	AM022KNMDEH/EU		AM022FNMDEH/EU
Ducted MSP	AM028ANMPKH/EU	2.8	Duct S WITH Pump	AM028KNMDEH/EU		AM028FNMDEH/EU
Ducted MSP	AM036ANMPKH/EU	3.6	Duct S WITH Pump	AM036KNMDEH/EU	AM036HNMPKH/EU	AM036FNMDEH/EU
Ducted MSP	AM045ANMPKH/EU	4.5	Duct S WITH Pump	AM045KNMDEH/EU	AM045HNMPKH/EU	AM045FNMDEH/EU
Ducted MSP	AM056ANMPKH/EU	5.6	Duct S WITH Pump	AM056KNMDEH/EU	AM056HNMPKH/EU	AM056FNMDEH/EU
Ducted MSP	AM071ANMPKH/EU	7.1	Duct S WITH Pump	AM071KNMDEH/EU	AM071HNMPKH/EU	AM071FNMDEH/EU
Ducted MSP	AM090ANMPKH/EU	9	Duct S WITH Pump	AM090KNMDEH/EU	AM090HNMPKH/EU	AM090FNMDEH/EU
Ducted MSP	AM112ANMPKH/EU	11.2	Duct S WITH Pump	AM112KNMDEH/EU	AM112HNMPKH/EU	AM112FNMDEH/EU
Ducted MSP	AM128ANMPKH/EU	12.8	Duct S WITH Pump		AM128HNMPKH/EU	
Ducted MSP	AM140ANMPKH/EU	14	Duct S WITH Pump		AM140HNMPKH/EU	
Ducted HSP	AM056ANHPKH/EU	5.6	High Static Duct - now WITH Pump	NEW size		
Ducted HSP	AM071ANHPKH/EU	7.1	High Static Duct - now WITH Pump	NEW size		
Ducted HSP	AM090ANHPKH/EU	9	High Static Duct - now WITH Pump	NEW size		
Ducted HSP	AM112ANHPKH/EU	11.2	High Static Duct - now WITH Pump	AM112HNHPKH/EU	AM112FNHDEH/EU	
Ducted HSP	AM128ANHPKH/EU	12.8	High Static Duct - now WITH Pump	AM128HNHPKH/EU	AM128FNHDEH/EU	
Ducted HSP	AM140ANHPKH/EU	14	High Static Duct - now WITH Pump	AM140HNHPKH/EU	AM140FNHDEH/EU	
DVM HR outdoor	AM080AXVGGR/EU	22.4	DVMS2 HR 3pipe high efficiency	AM080JXVHGR/ET		
DVM HR outdoor	AM100AXVGGR/EU	28	DVMS2 HR 3pipe high efficiency	AM100JXVHGR/ET		
DVM HR outdoor	AM120AXVGGR/EU	33.6	DVMS2 HR 3pipe high efficiency	AM120JXVHGR/ET		
DVM HR outdoor	AM140AXVGGR/EU	40	DVMS2 HR 3pipe high efficiency	AM140JXVHGR/ET		
DVM HR outdoor	AM160AXVGGR/EU	45	DVMS2 HR 3pipe high efficiency	AM160JXVHGR/ET		
DVM HR outdoor	AM180AXVGGR/EU	50.4	DVMS2 HR 3pipe high efficiency	AM180JXVHGR/ET		
DVM HR outdoor	AM200AXVGGR/EU	56	DVMS2 HR 3pipe high efficiency	AM200JXVHGR/ET		
DVM HR outdoor	AM220AXVGGR/EU	61.6	DVMS2 HR 3pipe high efficiency	AM220JXVHGR/ET		
DVM HR outdoor	AM240AXVGGR/EU	67.2	DVMS2 HR 3pipe high efficiency	AM240MXVGNR/ET		
DVM HR Outdoor	AM260AXVGGR/EU	72.8	DVMS2 HR 3pipe high efficiency	AM260MXVGNR/ET		
DVM HP Outdoor	AM080AXVGGH/EU	22.4	DVMS2 HP 2pipe high Efficiency	AM080JXVHGH/ET		
DVM HP Outdoor	AM100AXVGGH/EU	28	DVMS2 HP 2pipe high Efficiency	AM100JXVHGH/ET		
DVM HP Outdoor	AM120AXVGGH/EU	33.6	DVMS2 HP 2pipe high Efficiency	AM120JXVHGH/ET		
DVM HP Outdoor	AM140AXVGGH/EU	40	DVMS2 HP 2pipe high Efficiency	AM140JXVHGH/ET		
DVM HP Outdoor	AM160AXVGGH/EU	45	DVMS2 HP 2pipe high Efficiency	AM160JXVHGH/ET		
DVM HP Outdoor	AM180AXVGGH/EU	50.4	DVMS2 HP 2pipe high Efficiency	AM180JXVHGH/ET		
DVM HP Outdoor	AM200AXVGGH/EU	56	DVMS2 HP 2pipe high Efficiency	AM200JXVHGH/ET		
DVM HP Outdoor	AM220AXVGGH/EU	61.6	DVMS2 HP 2pipe high Efficiency	AM220JXVHGH/ET		
DVM HP Outdoor	AM240AXVGGH/EU	67.2	DVMS2 HP 2pipe high Efficiency	AM240KXVGGH/ET		
DVM HP Outdoor	AM260AXVGGH/EU	72.8	DVMS2 HP 2pipe high Efficiency	AM260KXVGGH/ET		
DVM HP Outdoor	AM080AXVAGH/EU	22.4	DVMS2 HP 2pipe standard EER	AM080JXVAGH/ET		
DVM HP Outdoor	AM100AXVAGH/EU	28	DVMS2 HP 2pipe standard EER	AM100JXVAGH/ET		
DVM HP Outdoor	AM120AXVAGH/EU	33.6	DVMS2 HP 2pipe standard EER	AM120JXVAGH/ET		
DVM HP Outdoor	AM140AXVAGH/EU	40	DVMS2 HP 2pipe standard EER	AM140KXVAGH/ET		
DVM HP Outdoor	AM160AXVAGH/EU	45	DVMS2 HP 2pipe standard EER	AM160KXVAGH/ET		
DVM HP Outdoor	AM180AXVAGH/EU	50.4	DVMS2 HP 2pipe standard EER	AM180KXVAGH/ET		
DVM HP Outdoor	AM200AXVAGH/EU	56	DVMS2 HP 2pipe standard EER	AM200KXVAGH/ET		
DVM HP Outdoor	AM220AXVAGH/EU	61.6	DVMS2 HP 2pipe standard EER	AM220KXVAGH/ET		
DVM HP Outdoor	AM240AXVAGH/EU	67.2	DVMS2 HP 2pipe standard EER	AM240KXVAGH/ET		
DVM HP Outdoor	AM260AXVAGH/EU	72.8	DVMS2 HP 2pipe standard EER	AM260KXVAGH/ET		

DVM S

Digital Variable Multi

CHILLER

DVM - VRF Hybrid Chiller



DVM - VRF CHILLER UNITS HP ~ 3 PHASE

Model Reference	Type	HP	Cool	Heat	usRTon	ESEER	Description	LIST PRICE €
AG042KSVANH/EU	HP	15	42.0kW	42.0kW	12	5.7	DVM S Chiller - without pump	16,090.00
AG056KSVANH/EU	HP	20	56.0kW	56.0kW	16	5.4	DVM S Chiller - without pump	16,792.00
AG070KSVANH/EU	HP	25	65.0kW	69.5kW	18.5	5	DVM S Chiller - without pump	17,978.00

* MCM-A00N REQUIRED TO COMMISSION SYSTEM



360 Cassette	Type	Cool	Heat	Description	LIST PRICE €
--------------	------	------	------	-------------	--------------

Circular 360 Cassette - Chilled Water FCU

AG060MN4PKH/EU	Chiller FCU	6.00kW	7.30kW	360 Cassette FCU (947mm diameter)	1,112.00
AG072MN4PKH/EU	Chiller FCU	7.20kW	8.50kW	360 Cassette FCU (947mm diameter)	1,232.00
AG090MN4PKH/EU	Chiller FCU	9.00kW	10.0kW	360 Cassette FCU (947mm diameter)	1,416.00
AG105MN4PKH/EU	Chiller FCU	10.0kW	10.7kW	360 Cassette FCU (947mm diameter)	1,624.00
PC4NUDMAN				360 Cassette Panel Square WHITE	167.00
PC4NUNMAN				360 Cassette Panel Round WHITE	167.00
PC4NBDMAN				360 Cassette Panel Square - BLACK	167.00
PC4NBNMAN				360 Cassette Panel Round - BLACK	167.00

FCU's can be used on 3rd Party Chilled Water Systems

4way Cassette - WindFree™ - Chilled Water FCU

NEW model



4-way Cassette	Type	Cool	Heat	Description	LIST PRICE €
AG060AN4DKH/EU	Chiller FCU	6.00kW	7.30kW	4way Cassette FCU (840x840)	923.00
AG072AN4DKH/EU	Chiller FCU	7.20kW	8.50kW	4way Cassette FCU (840x840)	953.00
AG090AN4DKH/EU	Chiller FCU	9.00kW	10.0kW	4way Cassette FCU (840x840)	1,181.00
AG105AN4DKH/EU	Chiller FCU	10.0kW	10.7kW	4way Cassette FCU (840x840)	1,280.00
PC4NUFMAN				WindFree 4-Way Cassette Fascia Panel	167.00
PC4NUCEAN				WindFree 4-Way Cassette Fascia Panel - PURE Filter	594.00
PC4NUXMAN				WindFree 4-Way Cassette Fascia Panel - AutoLIFT	414.00

FCU's can be used on 3rd Party Chilled Water Systems

1way Cassette - Chilled Water FCU



1-way Cassette	Type	Cool	Heat	Description	LIST PRICE €
AG026MN1DEH/EU	Chiller FCU	2.60kW	2.90kW	1way Cassette FCU	896.00
AG032MN1DEH/EU	Chiller FCU	3.00kW	3.35kW	1way Cassette FCU	928.00
PC1NUSMAN				Slimline 1-Way Cassette Fascia Panel Stripe	162.00
AG042MN1DEH/EU	Chiller FCU	4.15kW	5.00kW	1way Cassette FCU	1,209.00
PC1BWSMAN				Slimline 1-Way Cassette WAVE STYLE Fascia Panel - 4.5kW	162.00

1way Cassette - WindFree™ - Chilled Water FCU



1-way Cassette	Type	Cool	Heat	Description	LIST PRICE €
AG026TN1DKH/EU	Chiller FCU	2.60kW	2.90kW	1way Wind-free Cassette FCU	921.00
AG032TN1DKH/EU	Chiller FCU	3.00kW	3.35kW	1way Wind-free Cassette FCU	956.00
PC1NWFMBN				Medium 1-Way Wind-free Chiller Cassette Fascia Panel	162.00
AG042TN1DKH/EU	Chiller FCU	4.15kW	5.00kW	1way Wind-free Cassette FCU	1,243.00
PC1BWFMBN				Large 1-Way Wind-free Chiller Cassette Fascia Panel	162.00

Cooling: Indoor temperature 27°C DB, 19°C WB / Water In/Out temperature 7°C, 12°C Heating: Indoor temperature 20°C DB, 15°C WB / Water In/Out temperature 45°C, 40°C

FCU's can be used on 3rd Party Chilled Water Systems

CHILLER

3rd Party FCUs

Built-in Samsung Control Board



Concealed FCU - vertical or Horizontal installation

Concealed FCU	Type	Cool	Heat	Description	LIST PRICE €
ACL-18DF	Chiller FCU	1.7kW	1.8kW	Concealed FCU incl. FCU kit and 3-way valve kit	821.00
ACL-25DF	Chiller FCU	2.4kW	2.3kW	Concealed FCU incl. FCU kit and 3-way valve kit	855.00
ACL-35DF	Chiller FCU	3.2kW	3.2kW	Concealed FCU incl. FCU kit and 3-way valve kit	920.00
ACL-55DF	Chiller FCU	5.7kW	5.7kW	Concealed FCU incl. FCU kit and 3-way valve kit	1,126.00
ACL-65DF	Chiller FCU	6.0kW	6.5kW	Concealed FCU incl. FCU kit and 3-way valve kit	1,216.00

* above units fitted with Samsung Chiller interface as standard (MIM-F00N)



Cased FCU - vertical or Horizontal installation

Cased FCU	Type	Cool	Heat	Description	LIST PRICE €
ACL-18DG	Chiller FCU	1.7kW	1.8kW	Cased FCU incl. FCU kit and 3-way valve kit	923.00
ACL-25DG	Chiller FCU	2.4kW	2.3kW	Cased FCU incl. FCU kit and 3-way valve kit	978.00
ACL-35DG	Chiller FCU	3.2kW	3.2kW	Cased FCU incl. FCU kit and 3-way valve kit	1,053.00
ACL-55DG	Chiller FCU	5.7kW	5.7kW	Cased FCU incl. FCU kit and 3-way valve kit	1,340.00
ACL-65DG	Chiller FCU	6.0kW	6.5kW	Cased FCU incl. FCU kit and 3-way valve kit	1,443.00

* above units fitted with Samsung Chiller interface as standard (MIM-F00N)

GALLETTI FCU ACCESSORIES & CONTROLS				Description	LIST PRICE €
ACL-A018HC	Heating coil 4-pipe			4-pipe installation heating coil for ACL-18, supplied loose	72.00
ACL-A025HC	Heating coil 4-pipe			4-pipe installation heating coil for ACL-25, supplied loose	91.00
ACL-A035HC	Heating coil 4-pipe			4-pipe installation heating coil for ACL-35, supplied loose	98.00
ACL-A055HC	Heating coil 4-pipe			4-pipe installation heating coil for ACL-55-65, supplied loose	156.00

ACL-A018V3	3-way valve for 4-pipe			3-way valve kit for heating coil for AC-18-35, supplied loose	135.00
ACL-A055V3	3-way valve for 4-pipe			3-way valve kit for heating coil for AC-55-65, supplied loose	135.00

ACL-ADV	Drain Pan Vertical			Auxiliary drain pan for vertical installation, supplied loose	12.00
ACL-ADH	Drain Pan Horizontal			Auxiliary drain pan for horizontal installation, supplied loose	14.00
ACL-ADP	Drain Pump			Drain pump, supplied loose	192.00

DVM S CHILLER & FCU ACCESSORIES & CONTROLS			LIST PRICE €
Model Reference	Description		
MCM-A00N	DVM Chiller Module Controller (Set-up, commissioning and control)		134.00
MWR-WG00JN	LCD COLOUR PREMIUM Wired Controller (NASA) - Fan coil controller		104.00
MWR-SH11N	Simplified Wired Remote Controller (NASA)		101.00
MCM-A300N	Touch Screen Controller NASA (Centralised management of up to 128 indoor units)		704.00

MSD-CAN1	S-Plasma Ion Kit for 4way & 360 Cassette		76.00
MIM-F00N	DVM Chiller FCU kit		255.00
MIM-F10N	DVM Chiller Hub PBA		53.00

ACL-A26V3	3-way valve for Samsung FCU	3-way valve kit for SAMSUNG FCUs AG26-42, supplied loose	156.00
ACL-A60V3	3-way valve for Samsung FCU	3-way valve kit for SAMSUNG FCUs AG60-105, supplied loose	167.00

MIM-D01AN	Data Management Server (DVM/FJM/SPLIT/ERV) central management of up to 256 indoor units, web server		1,212.00
MIM-B16N	Pulse Input Module (PIM) - Watt Hour Meter Interface Module (connect up to 8 watt hour meters)		338.00
MIM-B17BN	BACnet DMS 2 (Data Management Server with Built in BACnet Gateway - maximum 256 indoor units)		2,231.00
MIM-B18BN	LONWorks DMS 2 (Data Management Server with Built in LONWorks Gateway - maximum 128 indoor units)		2,231.00
MIM-B19N	MODBUS interface Module 48 indoor units (1 outdoor)		153.00

A Resource Bank For All Things Samsung

As one of Samsung's registered Climate Solutions partners, you will have access to our Partner Portal and its many benefits. Whether you are looking for marketing materials or technical product documentation, requesting technical support or subscribing for training, the Samsung Climate Solutions Partner Portal offers you everything you need to consistently deliver the best results.

Access Technical Resources

The Technical Resources section allows you to find all relevant information to understand the product's functionality and to prepare and design projects. Ranging from technical data books, BIM files and certificates to exploded views, drawings and different kinds of manuals, a library full of technical information is at your fingertips.

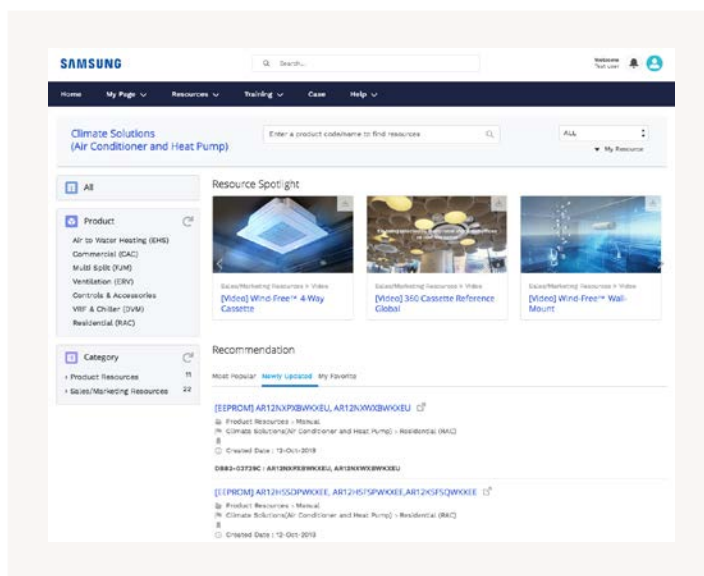
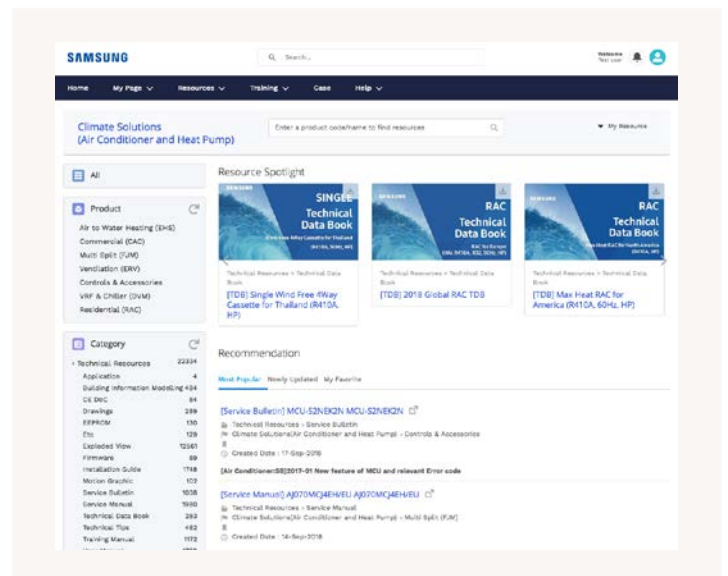

Obtain Marketing Resources

Potential buyers like to know you are on the cutting edge of Samsung's latest innovations. To allow you to align with Samsung's marketing initiatives, the Partner Portal provides you with useful downloadable assets such as images and videos, designed to make your marketing activities easy and effective.

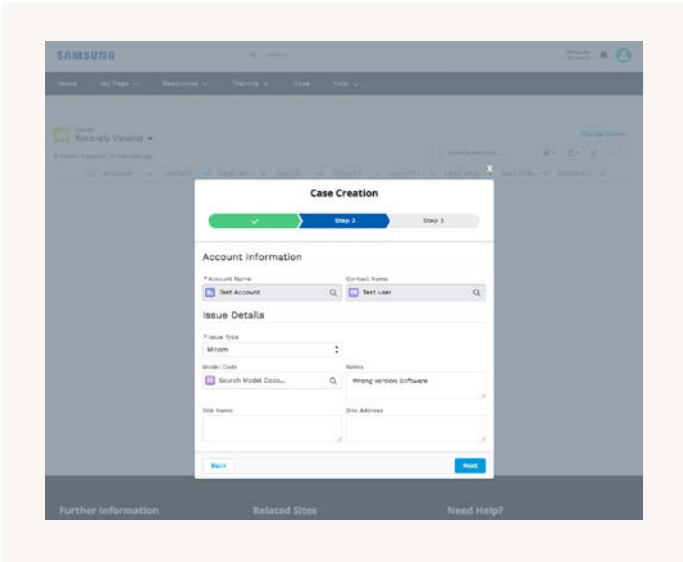

Request Technical Support

Through the Samsung Partner Portal you can easily request technical support by raising your case using our built-in ticketing system. You can rest assured that our well-trained technical experts will work to solve your issue as soon as possible.

Register for Training

If you are dedicated to becoming a Samsung climate solutions expert, you can access Samsung’s educational portal for training sessions by experienced trainers. The portal allows you to search for online courses and materials, test your climate solutions knowledge, and more. The Samsung Business Academy is here to help you succeed.*

* The registration process and availability of training courses may differ per country. Please contact your direct Samsung contact person for more information.

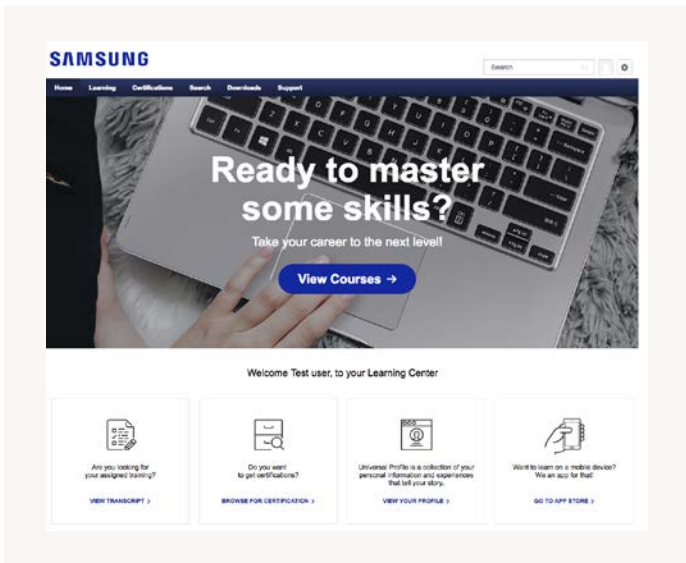

How To Access



Register

To register for the Samsung Climate Solutions Partner Portal, open your web browser* and go to partnerhub.samsung.com/climate to complete the registration form.



Access

Your information will be verified and your account will be activated. You will receive your personal login credentials.



Manage account

Keep your account details up to date and invite your colleagues to join.



Search and download

Access a full library of resources, request technical support, or sign up for a Climate Solutions Academy training session.

* The recommended web browser for using the Samsung Climate Solutions Partner Portal is Google Chrome.



Learn more about Samsung Climate Solutions at:
www.samsung.com/climate

Samsung Electronics Air Conditioner Europe B.V.
Evert Van Beekstraat 310
1118 CX Schiphol
Netherlands

Terms & Conditions

This price list is subject to our Standard Terms and Conditions of Sale.

This price list will take effect from 1 April 2021 and will remain valid until further notice.

All prices quoted are excluding VAT and will be charged at the prevailing rate. Our standard delivery terms are 3 to 4 days, delivered kerbside to your Ireland premises, from our acceptance of your order.

All deliveries will be made during normal working hours with unlimited access. AM/PM, Timed deliveries, or any additional delivery requirements will be subject to additional costs.

Samsung cannot accept the return of goods that have been unboxed and/or signs of visible damage to the packaging or the unit within, unless reported to Samsung in writing <72hrs following delivery.

DISCLAIMER

Although we endeavour to ensure the technical and factual accuracy of all the content of this document, associated attachments and additional brochures, this cannot be guaranteed. For further information on liabilities and our terms and conditions, please visit www.samsung.com/climate.

Electrical information provided is guidance and values should be confirmed by a qualified electrician.

SAMSUNG